

Operating Instructions

BA 6603 EN 12.02

Escalator gear units of Types
CG35-125, CG19-160, CRW160

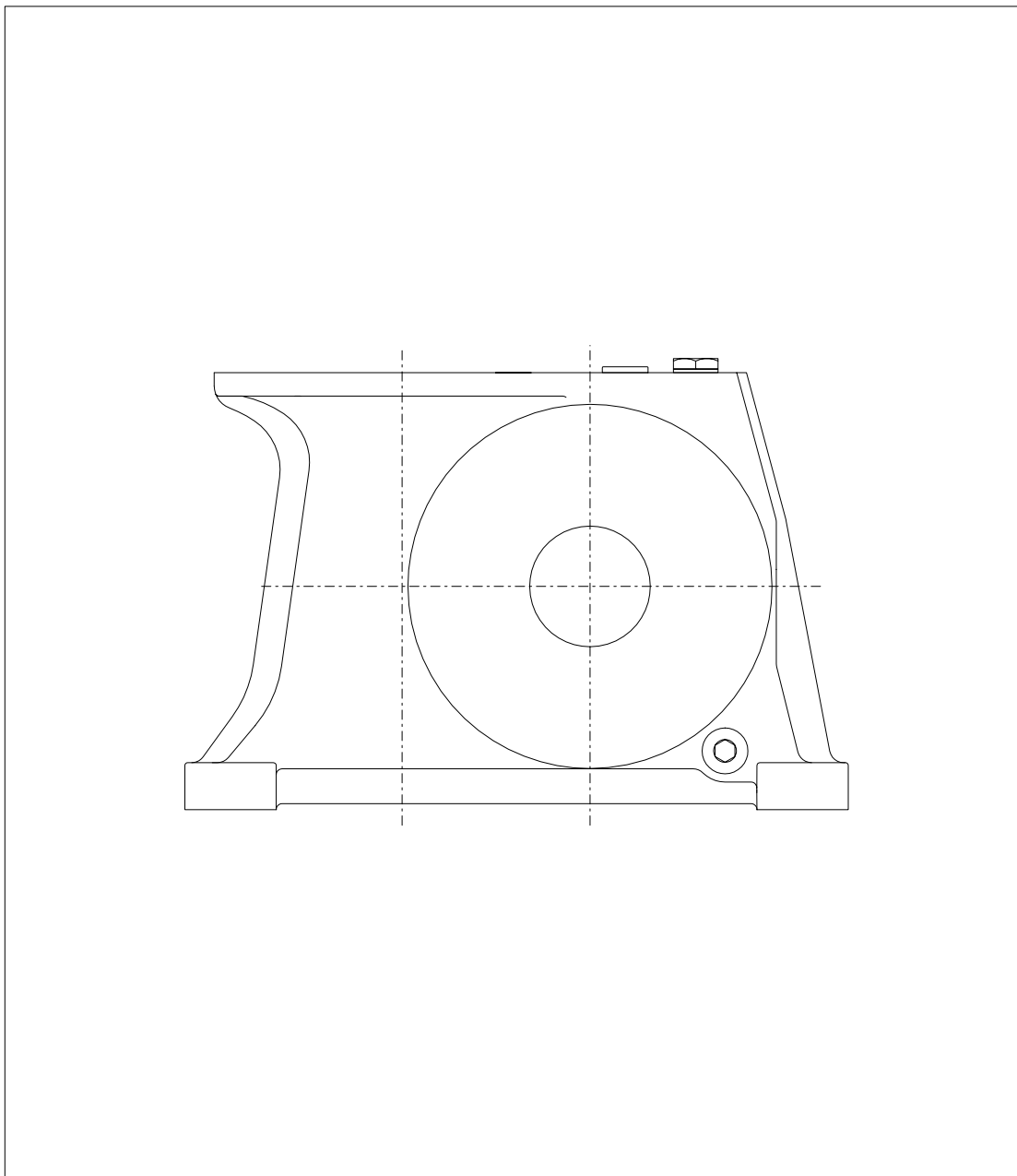

FLENDER

1.	Technical data	4
1.1	Rating plate	4
1.2	Dimensions	4
1.3	Weights	5
1.4	Oil quantities	5
1.5	Measuring-surface sound level	5
2.	General notes	6
2.1	Introduction	6
2.2	Copyright	6
3.	Safety notes	7
3.1	Proper use	7
3.2	Obligations of the user	7
3.3	Environmental protection	7
3.4	Special dangers	8
3.5	Warnings and symbols used in these Instructions (BA)	8
4.	Handling and storage	8
4.1	Scope of supply	8
4.2	Handling	8
4.3	Storing the gear unit	9
4.4	Standard corrosion protection	9
5.	Technical description	9
5.1	General	9
5.2	Symbols	9
5.3	Coupling	10
5.4	Attachment of motors	10
5.5	Attachment of chain sprockets	10
6.	Assembly	10
6.1	General information on installation	10
6.2	Mounting surface	10
6.3	Description of installation work	11
7.	Start-up	12
7.1	Oil filling	12
7.2	Connecting up the motor	12
7.3	Start-up	12
8.	Operation	12
9.	Faults, causes and remedy	13
9.1	General information on faults and malfunctions	13
9.2	Possible faults	13
10.	Maintenance and repair	14
10.1	General notes on maintenance	14
10.2	Description of maintenance and repair work	14
10.2.1	Changing the oil	14
10.2.2	Cleaning vent	15
10.2.3	Clean drive	15
10.2.4	Checking tightness of fastening bolts	15
10.3	Lubricants	15
10.3.1	Oil types	16

11.	Spare parts, customer-service addresses	17
11.1	Stocking spare parts	17
11.2	Spare-part and customer service addresses	17
11.3	Spare parts lists	18
11.4	Spare parts lists	18
11.5	Spare parts drawings	18
11.5.1	Left-hand version	18
11.5.2	Right-hand version	18
11.5.3	Output shaft both sides	18
12.	Declaration by the manufacturer	23

1. Technical data

1.1 Rating plate

The following technical data are shown on the gear unit rating plate.

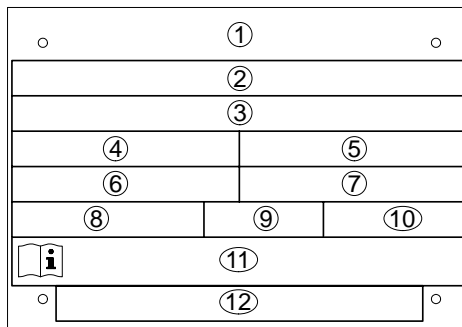

- | | |
|--|--|
| ① Company logo and production location | ⑦ Speed n_2 |
| ② Special information | ⑧ Type of oil |
| ③ Order no. - item - serial no. | ⑨ Viscosity of oil in VG class |
| ④ Type / Size | ⑩ Quantity of oil in litres for main housing |
| ⑤ Torque T_2 in Nm | ⑪ Operating instructions number |
| ⑥ Speed n_1 | ⑫ Special information |

Further data are given in the supply agreement and in these operating instructions.

1.2 Dimensions

For the main dimensions, please refer to the following table. For other dimensions, refer to the dimensional drawings, which are available on request.

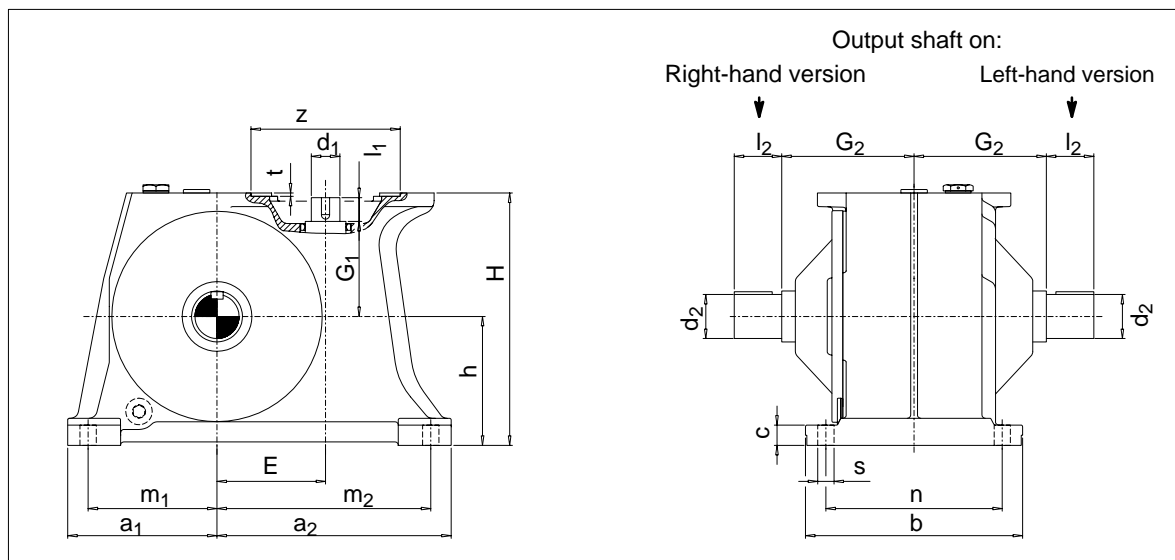

Type	a_1	a_2	b	c	d_1	l_1	G_1	d_2	l_2	G_2	E	h	H	m_1	m_2	n	s	z	t
CG35-125	175	300	256	24	38m6	35	123	55m6	56	165	125	145	310	145	270	200	24	180H7	5
CG19-160 CRW160	220	345	316	30	42m6	35	140	65m6	70	195	160	190	372	190	315	260	24	220H7	5

The type CRW160 gear unit is also available with a reduced construction height $h = 160$ mm, $H = 342$ mm.

1.3 Weights

For the weight of the gear unit **without** oil filling, refer to the following table.

Type	Weight without oil filling
	approx. kg
CG35-125	70
CG19-160 CRW160	136

1.4 Oil quantities

For the oil quantity to be poured into the gear unit, refer to the following table. The required oil quantity is also indicated on the rating plate.

Type	Gear unit version	
	Left-hand version	Right-hand version or output both sides
	approx. l	approx. l
CG35-125	7	9
CG19-160 CRW160	12	16

1.5 Measuring-surface sound level

The gear unit at an input speed of 1000 or 1200 1/min has a measuring-surface sound-pressure level of 58 + 2 dB(A) at a distance of 1 m from the surface of the gear unit.

Measurement is carried out to DIN 45 635 Parts 1 and 23 by the sound-intensity method and at at least 30 % rated output.

The sound-pressure level applies to the gear unit when heated up. If repeat measurements on site do not produce conclusive results with regard to measuring technology, the measurement obtained on the FLENDER test bench will apply.

The given sound pressure level was determined by statistical evaluations of our quality control department. In accordance with the confidence coefficient, it can be expected that the gear unit noise will be within the given value.

2. General notes

2.1 Introduction

These Operating Instructions (BA) are an integral part of the gear unit supplied and must be kept in its vicinity for reference at all times.

Caution!

All persons involved in installation, operation, maintenance and repair must have read and understood these Operating Instructions and must comply with them. We accept no responsibility for damage or disruption caused by disregard of these Instructions.

The gear unit described here has been manufactured in compliance with the recognised safety regulations and the state of technical development applying at the time these operating instructions were printed.

In the interest of technical progress we reserve the right to make changes to the individual assemblies and accessories which we regard as necessary to preserve their essential characteristics and improve their efficiency and safety.

2.2 Copyright

The copyright to these Operating Instructions is held by **FLENDER GMBH**.

These Operating Instructions must not be wholly or partly reproduced for competitive purposes, used in any unauthorised way or made available to third parties without our agreement.

Technical enquiries should be addressed to the following works

FLENDER GMBH

D-46393 Bocholt

Tel.: 02871/92-0

Fax: 02871/92-2596

or to one of our customer-service addresses. A list of our customer-service addresses is given in section 11, "Spare parts, customer-service addresses".

3. Safety notes

3.1 Proper use

- The gear unit has been manufactured in accordance with the state of the art and is delivered in a condition for safe and reliable use. Unauthorised changes, additions and modifications which reduce reliability and safety are not permitted. This applies equally to safety features designed to prevent accidental contact.
- The gear unit may be used and operated only in accordance with the conditions laid down in the service and supply contract.

3.2 Obligations of the user

- The user must ensure that all persons involved in installation, operation, maintenance and repair have read and understood these Operating Instructions and comply with them at all times in order to:
 - avoid injury or damage,
 - ensure the safety and reliability of the unit,

and

- avoid disruptions and environmental damage through incorrect use.
- During transport, assembly, installation, disassembly, operation and maintenance the relevant safety and environmental regulations must be complied with.
- The gear unit should be operated, maintained or repaired by authorised, trained and qualified personnel.
- The gear unit must not be cleaned using high-pressure cleaning equipment.
- All work must be carried out with great care and with due regard to safety.
- All work on the gear unit must be carried out only when it is at a standstill. Secure the drive unit to prevent unintentional switch-on! A notice should be attached to the start switch stating clearly that work on the gear unit is in progress.
- No welding work should be done on the gear unit. The gear units must not be used as an earthing point for welding operations. Toothed parts and bearings may be irreparably damaged by welding.
- If any changes are noticed during operation (e.g. overheating or unusual noises), the drive assembly must be switched off immediately.
- Exposed rotating parts must be fitted with guards to prevent physical contact.
- If the gear unit is intended for installation in plant or machinery, the manufacturer of such plant or machinery must ensure that the contents of these Instructions are incorporated in his own instructions.
- Notices attached to the gear unit, e.g. rating plate, direction arrows etc. must always be observed. They must be kept free from dirt and paint at all times. Missing plates must be replaced.
- All spare parts must be obtained from FLENDER.

3.3 Environmental protection

- When changing oil, the used oil must be collected in suitable containers. Any spillage of oil must be removed immediately.
- Preservative agent should be stored separately from used oil.
- Used oil, preservative agent, oil-binding agents and oil-soaked cloths must be disposed of in accordance with environmental legislation.

3.4 Special dangers

- Depending on operating conditions, the surface of the gear unit may heat up considerably.
Danger of burns!
- When changing oil, take care to prevent scalding by hot oil.

3.5 Warnings and symbols used in these Instructions (BA)



This symbol indicates safety measures which must be observed to avoid **personal injury**.

Caution!

This symbol indicates safety measures which must be observed to avoid **damage to the gear unit**.

Note:

This symbol indicates general **operating instructions** which are of particular importance.

4. Handling and storage

Note: Observe the "Safety instructions" in section 3.

4.1 Scope of supply

The products supplied are listed in the despatch papers. Check immediately on receipt to ensure that all the products listed have actually been delivered. Parts damaged during transport or missing parts must be reported in writing immediately.

4.2 Handling



When handling FLENDER products, use only lifting and handling equipment of sufficient load-bearing capacity!

Different forms of packaging may be used, depending on the size of the unit and method of transport. Unless otherwise agreed, the packaging complies with the **HPE Packaging Guidelines**.

The symbols marked on the packaging must be observed at all times. These have the following meanings:

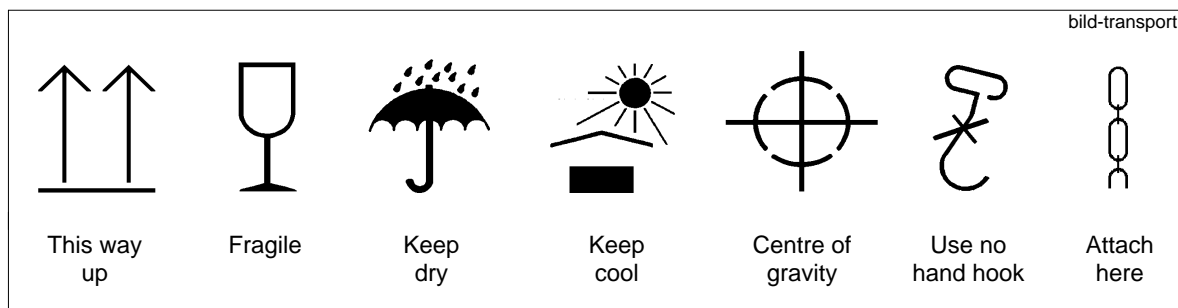

The gear unit must always be transported with due care to avoid danger to persons and the gear unit. If, for example, the free shaft ends are knocked, this may damage the gear unit.

Caution!

To transport and handle the gear unit, suitable means of attachment (e.g. eye bolts) must be screwed into the tapped holes provided for this purpose on the upper side of the housing. Do not use the front threads at the shaft ends to attach eye bolts for transport.

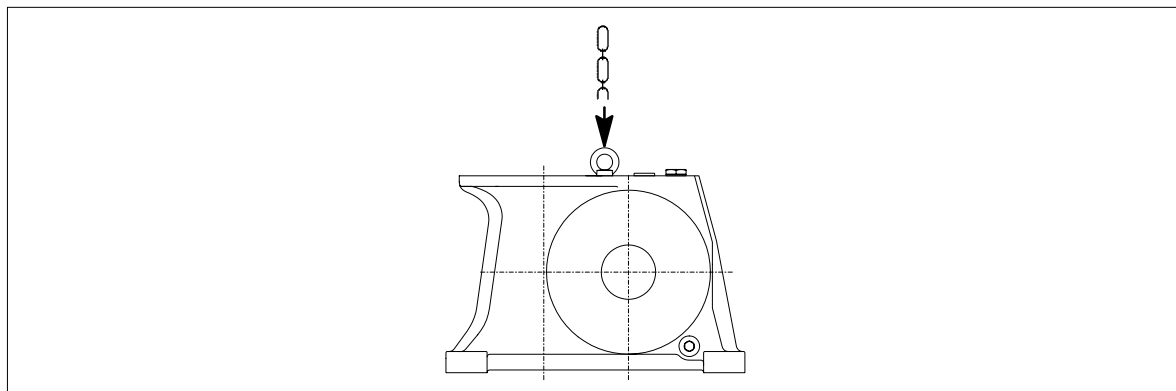

4.3 Storing the gear unit

The gear unit must be stored on a vibration-free base in a place protected from the weather.



Do not stack gear units on top of one another.

Caution!

If the gear unit is being stored out of doors, it must be particularly carefully covered, and care must be taken that neither moisture nor foreign material can collect on the unit.

4.4 Standard corrosion protection

The shaft ends have been provided with a rust-preventive paint coating. It is resistant to seawater and tropical conditions for a period of 12 months.

The properties of the outer paint coat are as follows: Resistant to acids, weak alkalis, solvents, atmospheric action, temperatures up to 120 °C (temporarily up to 140 °C) and to tropical conditions.

The gear unit is delivered **without** oil filling. The internal gear parts have been treated with a preservative. This preservative is sufficient for normal transport conditions (including overseas transport) and for a period of 6 months until initial start-up.

For longer periods of storage (> 6 months) we advise regular checking and, if necessary, renewal of the internal and external preservation (see section 7, "Start-up").

5. Technical description

Note: Observe the "Safety instructions" in section 3.

5.1 General

The gear unit is a worm-gear unit. It is outstanding for its quiet running and high efficiency.

5.2 Symbols

Symbols for venting, oil filling, oil level and oil drainage:

Breather:



Oil inlet:



Oil level:



Oil drain:

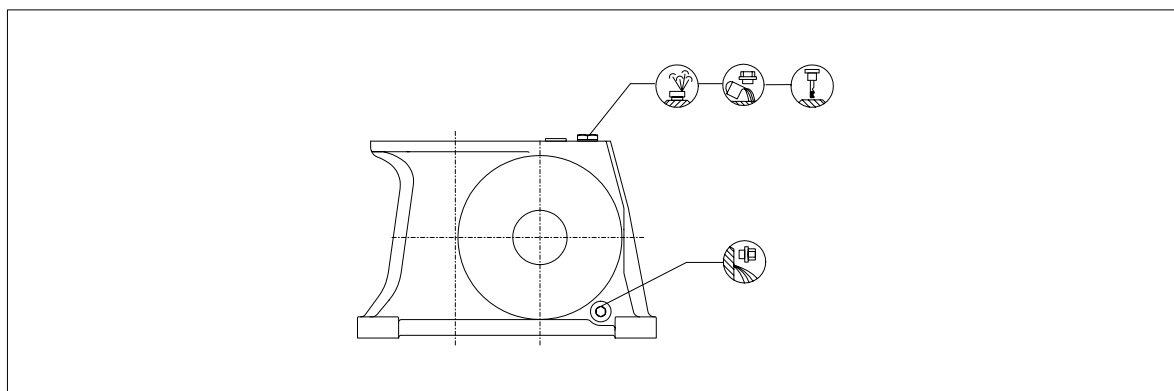

5.3 Coupling

A flexible coupling must be provided between the motor and the gear unit on the input side.

The special operating instructions should be observed for operation of the couplings.

5.4 Attachment of motors

When attaching motors, the Operating Instructions for the motor are to be observed.

Caution!

No motor with a speed exceeding the speeds specified for the gear unit must be used, as this may cause damage to the gear unit.

5.5 Attachment of chain sprockets

The output shaft of the gear unit is suitable for mounting a chain sprocket. The rolling bearings on the output shaft are adequately dimensioned to absorb the forces on the chain sprocket.

6. Assembly

Note: Observe the "Safety instructions" in section 3.

6.1 General information on installation

Assembly and installation work must be done with great care by trained and qualified personnel. The manufacturer cannot be held liable for damage caused by incorrect assembly and installation.

During the planning phase sufficient space must be left around the drive for later care and maintenance work.

Adequate lifting equipment must be available before beginning the installation and assembly work.

Caution!

**No welding work must be done on the drive.
The drive must not be used as an earthing point for welding operations.
Toothed parts and bearings may be irreparably damaged by welding.**

Caution!

All the fastening points provided by the design of the unit must be used.

The air feed for cooling the drive must not be impaired.

A means of monitoring the oil level must be provided.

6.2 Mounting surface

The mounting surface must be horizontal and even.

The perm. unevenness is 0.2 mm.

The mounting surface is rigid and robust enough to withstand the forces set up.

6.3 Description of installation work

- Remove anti-corrosive paint on the shafts and connecting surfaces with cleaning medium

Caution!

The cleaning medium must not be allowed to come in contact with the shaft sealing rings.



**Ensure adequate ventilation. Do not smoke!
Danger of explosion!**

- Stand gear unit on the mounting surface and fasten down.

Fastening bolts or nuts must be tightened to the prescribed torque. For the correct torque, refer to item 10.2.4. Bolts of the minimum strength class 8.8 must be used.

- Mount chain sprocket on the output shaft and secure.

Caution!

Never use force or knock the couplings into position, as this will damage the rolling bearings, locking rings, etc.

- Mount coupling on the input shaft and secure (the gear units are in some cases supplied with the coupling mounted).

Caution!

Never use force or knock the couplings into position, as this will damage the rolling bearings, locking rings, etc.

Caution!

The operating instructions for the part to be attached must be observed.

- Attach motor

Caution!

The operating instructions for the motor to be attached must be observed.

7. Start-up

Note: Observe the "Safety instructions" in section 3.

7.1 Oil filling

Caution!

Before starting up the oil must be poured into the gear unit up to the lower mark or at maximum up to the upper mark on the oil dipstick. The oil quantity indicated on the rating plate is a reference value.

Note: **Only** oil with a viscosity of VG 460 must be poured into the gear unit.

Various lubricants are indicated in the lubricant table (see section 10) according to the oil manufacturers' recommendations. Equivalent brands of non-foaming oil by other manufacturers may also be used. It is important to use the type of oil (synthetic or mineral oil) specified on the nameplate. However, we cannot guarantee that a selected lubricant is completely suitable.

7.2 Connecting up the motor

Caution!

The operating instructions for the attached motor must be observed.



Work on the terminal box and current-carrying parts must always be carried out only by specially trained personnel. Observe special safety regulations.

7.3 Start-up

The gear unit must then be run on intermittent load, i.e. run on normal load for a few minutes, alternating with breaks several times the length of the operating cycle. The duty cycle can gradually be increased up to normal operation, while at the same time monitoring the operating temperature. Operating temperatures up to approx. 100 °C are permissible.

8. Operation

Note: Observe the "Safety instructions" in section 3.

During operation the gear unit must be monitored for:

- excessive operating temperature
- changes in gear noise
- possible oil spillage

Caution!

If there are any irregularities during operation, the cause of the malfunction should be determined with the aid of the Troubleshooting Table (Section 9). This table contains a list of possible faults, their causes and suggested remedies.

If the cause cannot be identified or the unit repaired with the facilities available, you are advised to contact one of our customer-service offices for specialist assistance (see section 11).

9. Faults, causes and remedy

Note: Observe the "Safety instructions" in section 3.

9.1 General information on faults and malfunctions

Note: Faults and malfunctions occurring during the guarantee period and requiring repair work on the gear unit must be carried out only by FLENDER Customer Service. We recommend continuing to use our Customer Service even after expiry of the guarantee period.



To remedy faults and malfunctions, the gear unit must always be taken out of service.

Secure the drive unit to prevent it from being started up unintentionally. Attach a warning notice to the start switch.

9.2 Possible faults

Malfunctions	Causes	Remedy
Changes in gear noise	Excessive bearing play	Contact Customer Service.
	Bearing defective	Contact Customer Service.
	Damage to gear teeth	Contact Customer Service.
	Fastening has worked loose	Tighten bolts / nuts to prescribed torque. Replace damaged bolts / nuts.
Operating temperature too high	Oil level in gear-unit housing too high or too low	Check the oil level at room temperature and, if necessary, adjust oil level
	Oil too old	Change oil. See section 10.
	Oil badly contaminated	Change oil. See section 10.
	Gear-unit housing very dirty	Clean gear-unit housing
	Bearing defective	Contact Customer Service.
Oil leak	Radial shaft sealing rings defective	Replace radial shaft sealing rings

Table 9.1: Faults, causes and remedies

10. Maintenance and repair

Note: Observe the "Safety instructions" in section 3.

10.1 General notes on maintenance

Note: Maintenance and repair work must be done with care by trained and qualified personnel only.

Adherence to the inspection intervals is part of the guarantee conditions.

Measures	Periods	Remarks
Check gear-unit temperature	monthly	permiss. 80 °C on housing, for higher temperatures, see item 9.1.
Check for unusual gear-unit noise	monthly	if changed, see item 9.1.
Check oil level	monthly	Oil level at least up to the lower mark and at maximum up to the upper mark on the oil dipstick, when the gear unit is cold and stationary
Check gear unit for leaks	monthly	
First oil change after start-up	after approx. 1500 (600) operating hours, but at latest after 6 years (3 years)	see item 10.2.1
subsequent oil changes	after approx. 20000 (10000) operating hours, but at latest after 6 years (3 years)	see item 10.2.1
Cleaning vent	simultaneously with oil change	see item 10.2.2
Clean drive	simultaneously with oil change	see item 10.2.3
Checking tightness of fastening bolts	simultaneously with oil change	see item 10.2.4

Table 10.1: Inspection intervals

Note: The times shown in brackets apply to mineral oils.

10.2 Description of maintenance and repair work

10.2.1 Changing the oil

Caution!

When changing the oil, always re-fill the gear unit with the same type of oil. Never mix different types of oil or oils made by different manufacturers. Never mix synthetic oils with mineral-based oils or with other synthetic oils.

Note: The oil must be drained off immediately after shutting down the drive and while the oil is still warm. The oil must be given sufficient time to drain off in order to remove oil sludge, abraded metal and oil residues. If iridescent abraded bronze particles appear in the oil, this is not in any way harmful.



There is a danger of scalding from the hot oil emerging from the housing. Wear protective gloves. Remove any oil spillage immediately with an oil-binding agent.

10.2.2 Cleaning vent

The oil dipstick is provided with a hole to vent the gear unit. If a dust layer has formed, the oil dipstick must be unscrewed and cleaned to free the venting hole.

10.2.3 Clean drive

- Stop the drive by switching off the drive unit



Secure the drive unit to prevent it from being started up unintentionally. Attach a warning notice to the start switch.

- Remove any dirt adhering to the drive with a hard brush.
- Remove any corrosion.

Caution!

The drive must not be cleaned with high-pressure cleaning equipment.

10.2.4 Checking tightness of fastening bolts

- Stop the drive by switching off the drive unit



Secure the drive unit to prevent it from being started up unintentionally. Attach a warning notice to the start switch.

- Check tightness of all fastening bolts with a torque wrench
- Fastening bolts or nuts must be tightened to the prescribed torque. For the tightening torque, see following table.

Tightening torques for bolts and nuts of strength class 8.8				
Thread	M 8	M10	M 12	M 16
Tightening torque (Nm)	25	49	86	210

Note: Damaged bolts must be replaced with new bolts of the same type and strength class.

10.3 Lubricants

For its gear units, FLENDER approves only CLP oils which contain ingredients to DIN 51517-3 for improvement of corrosion protection, resistance to ageing, and which reduce wear in mixed-friction areas.

Note: For the various makes of oil to be used, refer to the following table. The latest information on all greases approved at FLENDER can be found at any time on our Internet homepage at <http://www.flender.com>.

Should you, for an important reason of your own, not wish to follow our recommendation, you assume responsibility for the technical suitability of the lubricant used.

We therefore recommend to our customers to select a lubricant from the table.

Note: **Only** oil with a viscosity of VG 460 must be poured into the gear unit.

If a different viscosity is selected, or oil of a type other than those recommended in these instructions, the operator assumes the responsibility for its technical suitability. In order to minimise the technical risk in such a case, we advise the use of a CLP oil of the above quality which should be accompanied by a statement of suitability by the oil manufacturer.

Caution!

Always comply with the information given on the rating plates and the written instructions for the gear units.













10.3.1 Oil types

- Mineral oils
- Synthetic oils (polyglycol)

The synthetic oils have a wider temperature range and a higher viscosity index (i.e. a flatter viscosity-temperature gradient) than the mineral oils. Guideline values for temperature range:

mineral oils approx. – 10 °C bis + 90 °C (short term +100 °C),
polyglycols approx. – 20 °C bis + 100 °C (short term +110 °C).

Note: The upper and lower temperatures (flash point, pour point) for using certain gear oils may deviate widely from the figures indicated. For these and other data and properties of the gear oils, refer to the technical-data sheets published by the oil manufacturers.

Lubricant	Viscosity ISO-VG DIN 51519 at 40 °C (mm ² /s)				
Mineral oils (MIN oil)	VG 460	Degol BG 460			Energol GR-XP 460
Polyglycols (PG oil)	VG 460	Degol GS 460	GEAR VSG 460	BERUSYNTH EP 460	Energol SG-XP 460
Lubricant	Viscosity ISO-VG DIN 51519 at 40 °C (mm ² /s)				
Mineral oils (MIN oil)	VG 460	Falcon CLP 460	SPARTAN EP 460		Klüberoil GEM1 - 460
Polyglycols (PG oil)	VG 460	Polydea PGLP 460	GLYCOLUBE 460	RENOLIN PG 460	SYNTHESO D 460 EP
Lubricant	Viscosity ISO-VG DIN 51519 at 40 °C (mm ² /s)				
Mineral oils (MIN oil)	VG 460	Mobilgear 634 Mobilgear XMP 460	Optigear BM 460		Ersolan 460
Polyglykole (PG oil)	VG 460	Mobil Glygoyle HE 460	Optiflex A 460	Shell Tivela SD	
Lubricant	Viscosity ISO-VG DIN 51519 at 40 °C (mm ² /s)				
Mineral oils (MIN oil)	VG 460	Tribol 1100 / 460			
Polyglycols (PG oil)	VG 460	Tribol 800 / 460			

11. Spare parts, customer-service addresses

11.1 Stocking spare parts

By stocking the most important spare and wearing parts on site you can ensure that the drive is ready for use at any time.

To order spare parts, refer to the spare-parts list.

For further information refer to the spare-parts drawing stated in the list.

We guarantee only the original spare parts supplied by us.

Caution!

Please note that spare parts and accessories not supplied by us have not been tested or approved by us. The installation and/or use of such products may therefore impair essential characteristics of the drive, thereby posing an active or passive risk to safety. FLENDER will assume no liability or guarantee for damage caused by spare parts and accessories not supplied by FLENDER.

Please note that certain components often have special production and supply specifications and that we supply you with spare parts which comply fully with the current state of technical development as well as current legislation.

When ordering spare parts, always state the following:

Order no. / Item	Type / Size	Part no.	Quantity
------------------	-------------	----------	----------

11.2 Spare-part and customer service addresses

When ordering spare parts or the services of our specialist engineers, apply first to FLENDER GMBH.

FLENDER Germany

A. FRIEDR. FLENDER GMBH

DE- 46393 Bocholt - Tel.: (0 28 71) 92-0 - Fax: (0 28 71) 92 25 96
E-mail: contact@flender.com • www.flender.com
Shipping address: Alfred - Flender - Strasse 77, DE- 46395 Bocholt

A. FRIEDR. FLENDER GMBH - Kupplungswerk Mussum

Industriepark Bocholt - Schlavenhorst 100 - DE- 46395 Bocholt - Tel.: (0 28 71) 92 28 68 - Fax: (0 28 71) 92 25 79
E-mail: anja.blits@flender.com • www.flender.com

A. FRIEDR. FLENDER GMBH - Werk Friedrichsfeld

Am Industriepark 2 - DE- 46562 Voerde - Tel.: (0 28 71) 92-0 - Fax: (0 28 71) 92 25 96
E-mail: contact@flender.com • www.flender.com

A. FRIEDR. FLENDER GMBH - Getriebewerk Penig

Thierbacher Strasse 24 - DE- 09322 Penig - Tel.: (03 73 81) 60 - Fax: (03 73 81) 8 02 86
E-mail: ute.tappert@flender.com • www.flender.com

FLENDER - TÜBINGEN GMBH

DE- 72007 Tübingen - Tel.: (0 70 71) 7 07-0 - Fax: (0 70 71) 70 74 00
E-mail: margit.holder@flender-motox.com • www.flender.com
Shipping address: Bahnhofstrasse 40, DE- 72072 Tübingen

LOHER GMBH

DE- 94095 Ruhstorf - Tel.: (0 85 31) 3 90 - Fax: (0 85 31) 3 94 37
E-mail: info@loher.de • www.loher.de
Shipping address: Hans-Loher-Strasse 32, DE- 94099 Ruhstorf

FLENDER SERVICE GMBH

DE- 44607 Herne - Tel.: (0 23 23) 940-0 - Fax: (0 23 23) 940 200
E-mail: klaus-peter.deppermann@flender-service.com • www.flender-service.com
Shipping address: Südstrasse 111, DE- 44625 Herne

A. FRIEDR. FLENDER GMBH - FLENDER GUSS

Obere Hauptstrasse 228-230, DE- 09228 Chemnitz / Wittgensdorf - Tel.: (0 37 22) 64-0 - Fax: (0 37 22) 64 21 89
E-mail: flender.guss@flender-guss.com • www.flender-guss.de

11.3 Spare parts lists

Spare parts									
Part no.	Description	Gear-unit version			Part no.	Description	Gear-unit version		
		Left-hand version	Right-hand version	Output both sides			Left-hand version	Right-hand version	Output both sides
7	O-Ring		x		26	O-Ring		x	
10	Shaft	x	x	x	28	Close fitting screw	x	x	x
13	Anti-friction bearing	x			29	Hexagon nut	x		
14	Anti-friction bearing	x	x	x	30	Washer	x	x	x
15	Anti-friction bearing	x	x	x	43	Worm shaft	x	x	x
23	Shaft seal	x	x	x	44	Wheel rim	x	x	x
24	Shaft seal	x	x	x	45	Wheel centre	x	x	x
25	Shaft seal	x	x	x					

11.4 Spare parts drawings

11.4.1 Left-hand version

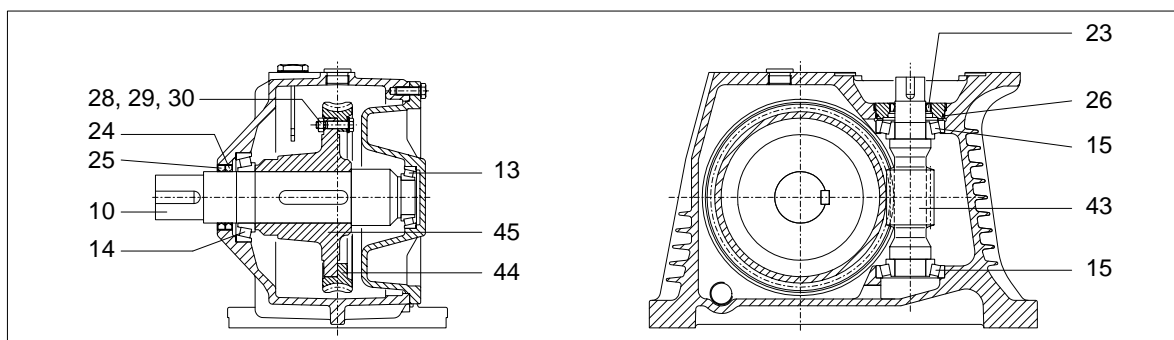

11.4.2 Right-hand version

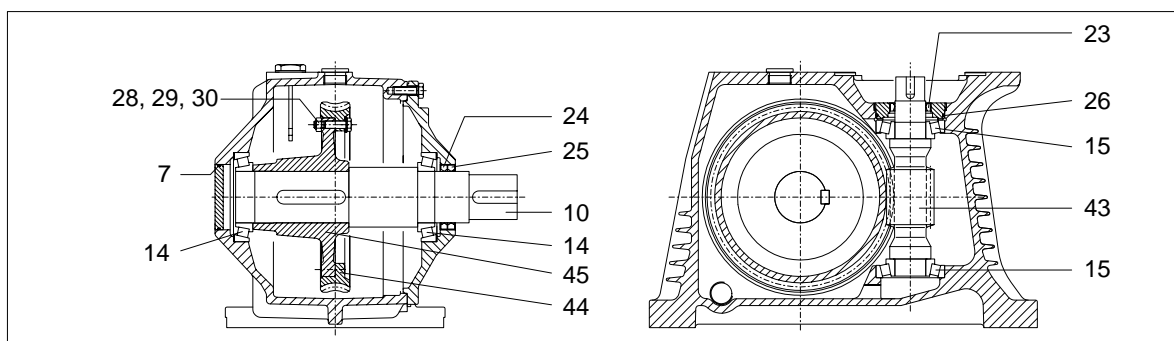

11.4.3 Output shaft both sides

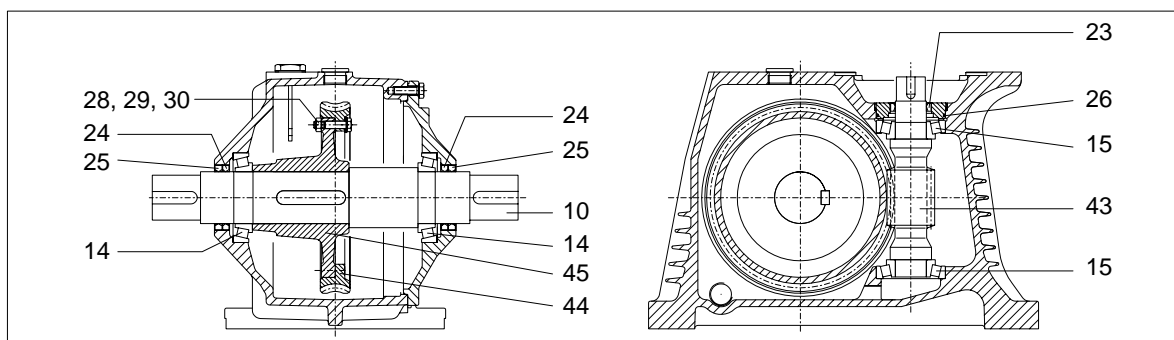

Germany

A. FRIEDR. FLENDER GMBH

DE- 46393 BOCHOLT - TEL.: (0 28 71) 92 - 0 - FAX: (0 28 71) 92 25 96

SHIPPING ADDRESS: ALFRED - FLENDER - STRASSE 77 - DE- 46395 BOCHOLT

E-mail: contact@flender.com • www.flender.com

VERTRIEBSZENTRUM HERNE

DE- 44607 Herne
Westring 303, DE- 44629 Herne
Tel.: (0 23 23) 4 97 - 0
Fax: (0 23 23) 4 97 - 2 50
E-mail: vz.herne@flender.com

VERTRIEBSZENTRUM STUTT GART

DE- 70472 Stuttgart
Friedlzheimer Strasse 3, DE- 70499 Stuttgart
Tel.: (07 11) 7 80 54 - 51
Fax: (07 11) 7 80 54 - 50
E-mail: vz.stuttgart@flender.com

VERTRIEBSZENTRUM MÜNCHEN

DE- 85750 Karlsfeld
Liebigstrasse 14, DE- 85757 Karlsfeld
Tel.: (0 81 31) 90 03 - 0
Fax: (0 81 31) 90 03 - 33
E-mail: vz.muenchen@flender.com

VERTRIEBSZENTRUM BERLIN

Schlossallee 8, DE- 13156 Berlin
Tel.: (0 30) 91 42 50 58
Fax: (0 30) 47 48 79 30
E-mail: vz.berlin@flender.com

EUROPE

AUSTRIA

Flender Ges.m.b.H.
Industriezentrum Nö-Süd
Strasse 4, Objekt 14, Postfach 132
AT - 2355 Wiener Neudorf
Phone: +43 (0) 22 36 6 45 70
Fax: +43 (0) 22 36 6 45 70 10
E-mail: office@flender.at
www.flender.at

BELGIUM & LUXEMBOURG

N.V. Flender Belge S.A.
Cyriel Buyssestraat 130
BE - 1800 Vilvoorde
Phone: +32 (0) 2 2 53 10 30
Fax: +32 (0) 2 2 53 09 66
E-mail: sales@flender.be

BULGARIA / ROMANIA

A. Friedr. Flender GmbH
Vertriebszentrum Europa-Ost
Schlossallee 8
DE - 13156 Berlin
Phone: +49 (0) 30 91 42 50 58
Fax: +49 (0) 30 47 48 79 30
E-mail: vz.berlin@flender.com

CROATIA / SLOVENIA BOSNIA-HERZEGOVINA

A. Friedr. Flender GmbH
Branch Office
c/o HUM - Naklada d.o.o.
Mandroviceva 3
HR - 10000 Zagreb
Phone: +385 (0) 1 - 2 30 60 25
Fax: +385 (0) 1 - 2 30 60 24
E-mail: flender@hi.hinet.hr

CZECH REPUBLIC

A. Friedr. Flender GmbH
Branch Office
Hotel DUO, Teplicka 17
CZ - 19000 Praha 9
Phone: +420 (0) 2 83 88 23 00
Fax: +420 (0) 2 83 88 22 05
E-mail: flender_pumpria@hotelduo.cz

DENMARK

Flender Scandinavia A/S
Rugmarken 35 B
DK - 3520 Farum
Phone: +45 - 70 22 60 03
Fax: +45 - 44 99 16 62
E-mail: kontakt@flenderscandinavia.com
www.flenderscandinavia.com

ESTHONIA / LATVIA / LITHUANIA

Flender Branch Office
Addinol Mineralöl Marketing OÜ
Suur-Sõjamäe 32
EE - 11415 Tallinn / Esthonia
Phone: +372 (0) 6 - 27 99 99
Fax: +372 (0) 6 - 27 99 90
E-mail: flender@addinol.ee
www.addinol.ee

FINLAND

Flender Oy
Ruosilantie 2 B
FI - 00390 Helsinki
Phone: +358 (0) 9 4 77 84 10
Fax: +358 (0) 9 4 36 14 10
E-mail: webmaster@flender.fi
www.flender.fi

FRANCE

Flender s.a.r.l.
3, rue Jean Monnet - B.P. 5
FR - 78996 Elancourt Cedex
Phone: +33 (0) 1 - 30 66 39 00
Fax: +33 (0) 1 - 30 66 35 13
E-mail: sales@flender.fr

SALES OFFICES:

Flender s.a.r.l.
36, rue Jean Broquin
FR - 69006 Lyon
Phone: +33 (0) 4 - 72 83 95 20
Fax: +33 (0) 4 - 72 83 95 39
E-mail: sales@flender.fr

Flender - Graffenstaden SA
1, rue du Vieux Moulin
FR - 67400 Illkirch-Graffenstaden
B.P. 84
FR - 67402 Illkirch - Graffenstaden
Phone: +33 (0) 3 - 88 67 60 00
Fax: +33 (0) 3 - 88 67 06 17
E-mail: flencomm@flender-graff.com

GREECE

Flender Hellas Ltd.
2, Delfon str.
GR - 11146 Athens
Phone: +30 (0) 210 - 2 91 72 80
Fax: +30 (0) 210 - 2 91 71 02
E-mail: flender@otenet.gr

Mangrinox S.A.
14, Grevenon str.
GR - 11855 Athens
Phone: +30 (0) 210 - 3 42 32 01
Fax: +30 (0) 210 - 3 45 99 28
E-mail: mangrinox@otenet.gr

Hungary

A. Friedr. Flender GmbH
Branch Office
Bécsi Út 3-5
HU - 1023 Budapest
Phone: +36 (0) 1 3 45 07 90 / 91
Fax: +36 (0) 1 3 45 07 92
E-mail: jambor.laszlo@matavnet.hu

ITALY

Flender Cigala S.p.A.
Via Privata da Strada Provinciale, 215
IT - 20040 Caponago (MI)
Phone: +39 (0) 02 95 96 31
Fax: +39 (0) 02 95 74 21 94
E-mail: info@flendercigala.it

THE NETHERLANDS

Flender Nederland B.V.
Industrieterrein Linsinghage
Platinastraat 133
NL - 2718 ST Zoetermeer
Postbus 725
NL - 2700 AS Zoetermeer
Phone: +31 (0) 79 3 61 54 70
Fax: +31 (0) 79 3 61 54 69
E-mail: sales@flender.nl
www.flender.nl

Flender Nederland B.V.
Lage Brink 5-7
NL - 7317 BD Apeldoorn
Postbus 1073
NL - 7301 BH Apeldoorn
Phone: +31 (0) 55 5 27 50 00
Fax: +31 (0) 55 5 21 80 11
E-mail: tom.alberts@flender-group.com

Bruinhof B.V.
Boterdiep 37
NL - 3077 AW Rotterdam
Postbus 9607
NL - 3007 AP Rotterdam
Phone: +31 (0) 10 4 97 08 08
Fax: +31 (0) 10 4 82 43 50
E-mail: info@bruinhof.nl
www.bruinhof.nl

NORWAY

Elektroprosess AS
Frysjaveien 40
NO - 0884 Oslo
Postboks 165 Kjelsås
N - 0411 Oslo
Phone: +47 (0) 2 2 02 10 30
Fax: +47 (0) 2 2 02 10 50 / 51
E-mail: post@elektroprosess.no

POLAND

A. Friedr. Flender GmbH
Branch Office
Oddział Mikolów, ul. Wyzwolenia 27
PL - 43 - 190 Mikolów
Phone: +48 (0) 32 2 26 45 61
Fax: +48 (0) 32 2 26 45 62
E-mail: flender@pro.onet.pl

PORTUGAL

RF Portugal - Rolamentos
e Componentes Lda.
Rua do Castanhal, 682
Zona Industrial da Maia, Sector II
PT - 4475 - 122 Maia
Phone: +351 (0) 22 - 9 47 89 51
Fax: +351 (0) 22 - 9 47 89 60
E-mail: info@rfportugal.com

RUSSIA

F & F GmbH
Tjuschina 4-6
RU - 191119, St. Petersburg
Phone: +7 (0) 8 12 1 64 11 26, 1 66 80 43
Fax: +7 (0) 8 12 1 64 00 54
E-mail: flendergus@mail.spbnit.ru

SLOVAKIA

A. Friedr. Flender GmbH
Branch Office
Vajanského 49, P.O. Box 286
SK - 08001 Presov
Phone: / Fax: 421 (0) 51 7 70 32 67
E-mail: micenko.flender@nextra.sk

SPAIN

Flender Ibérica S.A.
Poligono Industrial San Marcos
Calle Morse, 31 (Parcela D-15)
ES - 28906 Getafe (Madrid)
Phone: +34 (0) 91 - 6 83 61 86
Fax: +34 (0) 91 - 6 83 46 50
E-mail: f-iberica@flender.es
www.flender.es

SWEDEN

Flender Svenska AB
Ellipsvägen 11
SE - 14175 Kungens kurva, Stockholm
Phone: +46 (0) 8 4 49 56 70
Fax: +46 (0) 8 4 49 56 90
E-mail: mail@flender.se
www.flender.se

SWITZERLAND

Flender AG
Zeughausstr. 48,
CH - 5600 Lenzburg
Phone: +41 (0) 62 8 85 76 00
Fax: +41 (0) 62 8 85 76 76
E-mail: info@flender.ch
www.flender.ch

TURKEY

Flender Güc Aktarma Sistemleri
Sanayi ve Ticaret Ltd. Sti.
IMES Sanayi Sitesi
E Blok 502. Sokak No. 22
TR - 81260 Dudullu - Istanbul
Phone: +90 (0) 2 16 4 66 51 41 / 42
Fax: +90 (0) 2 16 3 64 59 13
E-mail: cuzkan@flendertr.com
www.flendertr.com

UKRAINE

A. Friedr. Flender GmbH
Branch Office
c/o DIV - Deutsche Industrie-
vertretung, Prospect Pobedy 44
UA - 252057 Kiev
Phone: +380 (0) 44 4 46 80 49 / 4 46 81 44
Fax: +380 (0) 44 2 30 29 30
E-mail: marina@div.kiev.ua

UNITED KINGDOM & EIRE

Flender Power Transmission Ltd.
Thornbury Works, Leeds Road
GB - Bradford
West Yorkshire BD3 7EB
Phone: +44 (0) 12 74 65 77 00
Fax: +44 (0) 12 74 66 98 36
E-mail: flenders@flender-power.co.uk
www.flender-power.co.uk

FLENDER

YUGOSLAVIA / ALBANIA / MACEDONIA

A. Friedr. Flender GmbH
Branch Office
c/o G.P.Inzenjering d.o.o.
III Bulevar 54 / 19
YU - 11070 Novi Beograd
Phone: +381 (0) 11 - 60 44 73
Fax: +381 (0) 11 - 3 11 67 91
E-mail: flender@eunet.yu

AFRICA

NORTH AFRICAN COUNTRIES

Please refer to Flender s.a.r.l.
3, rue Jean Monnet - B.P. 5
FR - 78996 Elancourt Cedex
Phone: +33 (0) 1 - 30 66 39 00
Fax: +33 (0) 1 - 30 66 35 13,
E-mail: sales@flender.fr

EGYPT

Sons of Farid Hassanen
81 Matbaa Ahlia Street
EG - Boulac 11221, Cairo
Phone: +20 (0) 2 5 75 15 44
Fax: +20 (0) 2 5 75 17 02
E-mail: hussein@sonfarid.com

SOUTH AFRICA

Flender Power Transmission (Pty.) Ltd.
Cnr. Furnace St & Quality Rd.,
P.O. Box 131,
ZA - Isando, 1600
Johannesburg
Phone: +27 (0) 11 5 71 20 00
Fax: +27 (0) 11 3 92 24 34
E-mail: contact@flender.co.za
www.flender.co.za

SALES OFFICES:

Flender Power Transmission (Pty.) Ltd.
Unit 3 Marconi Park,
9 Marconi Crescent, Montague Gardens
P.O. Box 28283,
ZA - Bothasig 7406
Cape Town
Phone: +27 (0) 21 5 51 50 03
Fax: +27 (0) 21 5 52 38 24
E-mail: flenderc@global.co.za

Flender Power Transmission (Pty.) Ltd.
Unit 3 Goshawk Park
Falcon Industrial Estate
P.O. Box 1608,
ZA - New Germany, 3620
Durban

Phone: +27 (0) 31 7 05 38 92
Fax: +27 (0) 13 6 92 34 52
E-mail: flenderd@global.co.za

Flender Power Transmission (Pty.) Ltd.
9 Industrial Crescent, Ext. 25,
P.O. Box 17609,
ZA - Witbank, 1035
Phone: +27 (0) 13 6 92 34 38
Fax: +27 (0) 13 6 92 34 52
E-mail: gert.els@flender.co.za

Flender Power Transmission (Pty.) Ltd.
Unit 14 King Fisher Park, Alton
Cnr. Ceramic Curve & Alumina Allee
P.O. Box 101995,
ZA - Meerensee, 3901
Richards Bay
Phone: +27 (0) 3 51 7 51 15 63
Fax: +27 (0) 3 51 7 51 15 64
E-mail: flenderr@global.co.za

AMERICA

BRASIL

Flender Brasil Ltda.
Rua Quadorze, 60 - Cidade Industrial
Caixa Postal 296
32.211-970,
BR - Contagem - MG
Phone: +55 (0) 31 33 69 20 00
Fax: +55 (0) 31 33 69 21 66

SALES OFFICES:

Flender Brasil Ltda.
Rua Cruzeiro, 549 - Barra Funda
01.137-000,
BR - São Paulo - SP
Phone: +55 (0) 11 36 12 30 30
Fax: +55 (0) 11 36 12 34 32
E-mail: flesao@uol.com.br

Flender Brasil Ltda.
Rua São José, 1010, S/22 - Centro
14.010-160,
BR - Ribeirão Preto - SP
Phone: +55 (0) 16 6 35 15 90
Fax: +55 (0) 16 6 35 11 05
E-mail: flender.ribpreto@uol.com.br

CANADA

Flender Power Transmission Inc.
215 Shields Court, Units 4 - 6
CA - Markham,
Ontario L3R 8V2
Phone: +1 (0) 9 05 3 05 10 21
Fax: +1 (0) 9 05 3 05 10 23
E-mail: flender@interlog.com
www.flenderpti.com

SALES OFFICES:

Flender Power Transmission Inc.
34992 Bemina Court
CA - Abbotsford-Vancouver,
B.C. V3G 1C2
Phone: +1 (0) 6 04 8 59 66 75
Fax: +1 (0) 6 04 8 59 68 78
E-mail: twickers@rapidnet.net

CHILE / ARGENTINA / BOLIVIA ECUADOR / PARAGUAY / URUGUAY

Flender Cono Sur Ltda.
Avda. Galvarino Gallardo # 1534
Providencia,
CL - Santiago
Phone: +56 (0) 2 2 35 32 49
Fax: +56 (0) 2 2 64 20 25
E-mail: flender@flender.cl
www.flender.cl

COLOMBIA

A.G.P. Representaciones Ltda.
Flender Liaison Office Colombia
Av Boyaca No 23A
50 Bodega UA 7-1
CO - Bogotá
Phone: +57 (0) 1 - 5 70 63 53
Fax: +57 (0) 1 - 5 70 73 35
E-mail: aguerrero@agp.com.co
www.agp.com.co

MEXICO

Flender de Mexico, S.A. de C.V.
Vista Hermosa No. 23
Col. Romero Vargas
Apdo. Postal 2 - 85, C.P. 72121
MX - Puebla, Puebla
Phone: +52 (0) 222 2 31 09 51
Fax: +52 (0) 222 2 31 09 13
E-mail: szugasti@flendermexico.com
www.flendermexico.com

SALES OFFICES:

Flender de Mexico, S.A. de C.V.
Lago Nargis No. 38,
Col. Granada, C.P. 11520,
MX - Mexico, D.F.
Phone: +52 (0) 55 52 54 30 37
Fax: +52 (0) 55 55 31 69 39
E-mail: info@flendermexico.com

Flender de Mexico, S.A. de C.V.
Rio Necaxa 1207,
Col. Valle Oriente, C.P. 66220
MX - Garza Garcia, N.L.
Phone: +52 (0) 81 83 63 82 82
Fax: +52 (0) 81 83 63 82 83
E-mail: info@flendermexico.com

PERU

Potencia Industrial E.I.R.L.
Calle Victor González Olaechea N° 110
Urb. La Aurora - Miraflores,
P.O.Box: Av. 2 de Mayo N° 679
Of.108-Miraflores
Casilla N° 392,
PE - Lima 18
Phone: +51 (0) 1 2 42 84 68
Fax: +51 (0) 1 2 42 08 62
E-mail: cesarzam@chavin.rcp.net.pe

USA

Flender Corporation
950 Tollgate Road, P.O. Box 1449
US - Elgin, IL. 60123
Phone: +1 (0) 8 47 9 31 19 90
Fax: +1 (0) 8 47 9 31 07 11
E-mail: dweilandt@flenderusa.com
www.flenderusa.com

Flender Corporation
Service Centers West
4234 Foster Ave.,
US - Bakersfield, CA. 93308
Phone: +1 (0) 6 61 3 25 44 78
Fax: +1 (0) 6 61 3 25 44 70
E-mail: flender1@lightspeed.net
E-mail: flender2@lightspeed.net

VENEZUELA

F. H. Transmisiones S.A.
Urbanización Buena Vista
Calle Johan Schafer o Segunda Calle
Municipio Sucre, Petare
VE - Caracas
Phone: +58 (0) 2 21 52 61
Fax: +58 (0) 2 21 18 38
E-mail: fhtransm@telcel.net.ve
www.fhtransmisiones.com

ASIA

SINGAPORE

Flender Singapore (Pte.) Ltd.
13A, Tech Park Crescent
SG - Singapore 637843
Phone: +65 98 97 94 66
Fax: +65 98 97 94 11
E-mail: flensi@singnet.com.sg
www.flender.com.sg

BANGLADESH / SRI LANKA

Please refer to Flender Limited
No. 2 St. George's Gate Road
5th Floor, Hastings,
IN - Kolkata - 700 022
Phone: +91 (0) 33 2 23 05 45
2 23 08 46, 2 23 52 85
Fax: +91 (0) 33 2 23 18 57
E-mail: flender@flenderindia.com

PEOPLE'S REPUBLIC OF CHINA

Flender Power Transmission
(Tianjin) Co. Ltd.
ShuangHu Rd.- Shuangchen Rd. West
Beichen Economic Development
Area (BEDA)
CN - Tianjin - 300400,
Phone: +86 (0) 22 26 97 20 63
Fax: +86 (0) 22 26 97 20 61
E-mail: flender@flendertj.com
www.flendertj.com

Flender Chief Representative Office
C-415, Lufthansa Center
50 Liangmaqiao Road, Chaoyang District
CN - Beijing - 100016,
Phone: +86 (0) 10 64 62 21 51
Fax: +86 (0) 10 64 62 21 43
E-mail: beijing@flenderprc.com.cn

Flender Shanghai
Representative Office
Unit 1101 - 1102
Harbour Ring Plaza
No. 18 Xizang Zhong Road
CN - Shanghai - 200 001,
Phone: +86 (0) 21 53 85 31 47
Fax: +86 (0) 21 53 85 31 46
E-mail: shanghai@flenderprc.com.cn

Flender Guangzhou Representative Office
Room 952, Business Tower, China Hotel
Lihua Road
CN - Guangzhou 510015,
Phone: +86 (0) 20 86 66 13 23
Fax: +86 (0) 20 86 66 28 60
E-mail: guangzhou@flenderprc.com.cn

Flender Chengdu Representative Office
Unit G, 6/F, Sichuan Guoxin
Mansion 77 Xiyu Street
CN - Chengdu 610015,
Phone: +86 (0) 28 86 19 83 72
Fax: +86 (0) 28 86 19 88 10
E-mail: chengdu@flenderprc.com.cn

FLENDER

Flender Wuhan Representative Office
Room 1104, Business Tower, Wuhan Plaza
688 Jiefang Road, Wuhan-hankou
CN - Wuhan 430022,
Phone: +86 (0) 27 85 48 67 15
Fax: +86 (0) 27 85 48 68 36
E-mail: wuhan@flenderprc.com.cn

INDIA

Flender Limited
Head Office:
No. 2 St. George's Gate Road,
5th Floor, Hastings,
IN - Kolkata - 700 022
Phone: +91 (0) 33 2 23 05 45, 2 23 08 46
Fax: +91 (0) 33 2 23 08 30
E-mail: flender@flenderindia.com

Flender Limited
Industrial Growth Center
Rakhajungle, Nimpura,
IN - Kharagpur - 721 302
Phone: +91 (0) 32 22 73 33 07, 22 73 33 08
Fax: +91 (0) 32 22 73 33 64
E-mail: works@flenderindia.com

SALES OFFICES:

Flender Limited
Eastern Regional Office
No. 2 St. George's Gate Road,
5th Floor, Hastings,
IN - Kolkata - 700 022
Phone: +91 (0) 33 2 23 05 45, 2 23 08 46
Fax: +91 (0) 33 2 23 08 30
E-mail: ero@flenderindia.com

Flender Limited
Western Regional Office
Plot. No. 23, Sector 19-A, Vashi
IN - Navi Mumbai - 400 705,
Phone: +91 (0) 22 7 65 72 27, 7 66 95 98
Fax: +91 (0) 22 7 65 72 28
E-mail: wro@flenderindia.com

Flender Limited
Southern Regional Office
41 Nelson Manickam Road
Aminjikarai,
IN - Chennai - 600 029
Phone: +91 (0) 44 3 74 39 21, 3 74 39 22
Fax: +91 (0) 44 3 74 39 19
E-mail: sro@flenderindia.com

Flender Limited
Northern Regional Office
209 - A, Masjid Moth, 2nd Floor
(Behind South Extension II)
IN - New Delhi
Phone: +91 (0) 11 6 25 02 21, 6 25 01 04
Fax: +91 (0) 11 6 25 63 72
E-mail: nro@flenderindia.com

INDONESIA

Flender Jakarta
Representative Office
Perkantoran Puri Niaga II
Jalan Puri Kencana Blok J1 No. 21
Kembangan,
ID - Jakarta Barat 11610
Phone: +62 (0) 21 5 82 86 24
Fax: +62 (0) 21 5 82 86 23
E-mail: bobwall@cbn.net.id

PT Flenindo Aditransimisi
Jl. Ketintang Wiyata VI No. 22
ID - Surabaya 60231
Phone: +62 (0) 31 8 29 10 82
Fax: +62 (0) 31 8 28 63 63
E-mail: gnsbyfld@indo.net.id

IRAN

Cimaghand Co. Ltd.
P.O. Box 15745-493,
No. 13, 16th East Street
Beyhaghi Ave., Argentina Sq.,
IR - Tehran 15156
Phone: +98 (0) 21 8 73 02 14, 8 73 02 59
Fax: +98 (0) 21 8 73 39 70
E-mail: cmgdir@dpimail.net

ISRAEL

Greenshpon Engineering Works Ltd.
Haamelim Street 20
P.O. Box 10108,
IL - 26110 Haifa
Phone: +972 (0) 4 8 72 11 87
Fax: +972 (0) 4 8 72 62 31
E-mail: sales@greenshpon.com
www.greenshpon.com

JAPAN

Ishibashi Manufacturing Co. Ltd.
4636 - 15, Oaza Kamitonno
Noogata City,
JP - Fukuoka, (Zip 822-0003)
Phone: +81 (0) 94 92 6 37 11
Fax: +81 (0) 94 92 6 39 02
E-mail: sales@ishibashi-mfg.com

KOREA

Flender Ltd.
7th Fl. Dorim Bldg.
1823 Bangbae-Dong, Seocho-Ku,
KR - Seoul 137-060
Phone: +82 (0) 2 34 78 63 37
Fax: +82 (0) 2 34 78 63 45
E-mail: flender@nuri.net

KUWAIT

South Gulf Company
Al-Reqai, Plot 1, Block 96
P.O. Box 26229
KW - Safat 13123
Phone: +965 (0) - 4 88 39 15
Fax: +965 (0) - 4 88 39 14
E-mail: adelameen@hotmail.com

LEBANON

Gabriel Acar & Fils s.a.r.l.
Dahr-el-Jamal, Zone Industrielle
Sin-el-Fil, B.P. 80484,
LB - Beyrouth
Phone: +961 (0) 1 49 47 86
Fax: +961 (0) 1 49 49 71
E-mail: gacar@beirut.com

MALAYSIA

Flender Singapore Pte. Ltd.
Sales Office:
37 A - 2, Jalan PJU 1/39
Dataran Prima
MY - 47301 Petaling Jaya
Selangor Darul Ehsan
Phone: +60 (0) 3 - 78 80 42 63
Fax: +60 (0) 3 - 78 80 42 73
E-mail: flender@tm.net.my

PAKISTAN

Please refer to
A. Friedr. Flender GmbH
DE - 46393 Bocholt
Phone: +49 (0) 28 71 - 92 22 59
Fax: +49 (0) 28 71 - 92 15 16
E-mail: ludger.wittag@flender.com

PHILIPPINES

Otec Philippines, Inc.
Rm 209-210 Quinio Building
#64 Sen. Gil J. Puyat Avenue
PH - Makati City,
Phone: +63 (0) 2 8 44 82 18, 8 92 46 36
Fax: +63 (0) 2 8 43 72 44
E-mail: litoq@otec-pemex.com

BAHRAIN / IRAQ / JORDAN / LYBIA

OMAN / QATAR / U.A.E. / YEMEN
Please refer to A. Friedr. Flender GmbH
Middle East Sales Office
IMES Sanayi Sitesi
E Blok 502, Sokak No. 22
TR - 81260 Dudullu-Istanbul
Phone: +90 (0) 2 16 4 99 66 23 / 4 99 66 24
Fax: +90 (0) 2 16 3 64 59 13
E-mail: meso@flendertr.com

SAUDI ARABIA

South Gulf Sands est.
Al-Thoqba, Kharaj Road Cross 1
P.O. Box 20434
SA - Al-Khobar
Phone: +966 (0) 3 - 8 93 76 33
Fax: +966 (0) 3 - 8 93 76 47
E-mail: adelameen@hotmail.com

SINGAPORE

Flender Singapore Pte. Ltd.
13 A, Tech Park Crescent
SG - Singapore 637843
Phone: +65 (0) - 68 97 94 66
Fax: +65 (0) - 68 97 94 11
E-mail: flender@singnet.com.sg
www.flender.com.sg

SYRIA

Misrabi Co & Trading
Mezzeh Autostrade Transportation
Building 4/A, 5th Floor
P.O. Box 12450
SY - Damascus
Phone: +963 (0) 11 - 6 11 67 94
Fax: +963 (0) 11 - 6 11 09 08
E-mail: ismael.misrabi@gmx.net

TAIWAN

A. Friedr. Flender GmbH
Taiwan Branch Company
1F, No. 5, Alley 17, Lane 194
Huanho Street, Hsichih
TW - Taipei Hsien
Phone: +886 (0) 2 26 93 24 41
Fax: +886 (0) 2 26 94 36 11
flender_tw@flender.com.tw

THAILAND

Flender Representative Office
23/F M Thai Tower, All Seasons Place
87 Wireless Road, Phatumwan
TH - Bangkok 10330
Phone: +66 (0) 2 - 6 27 91 09
Fax: +66 (0) 2 - 6 27 90 01
E-mail: christian.beckers@flender.th.com

VIETNAM

Flender Representative Office
Suite 6/6A, 16F Saigon Tower
29 Le Duan Street, District 1
Ho Chi Minh City
VN - Vietnam
Phone: +84 (0) 8 - 8 23 62 97
Fax: +84 (0) 8 - 8 23 62 88
E-mail: flender@hcm.vnn.vn

A U S T R A L I A

Flender (Australia) Pty. Ltd.
9 Nello Place, P.O. Box 6047
Whetherill Park, N.S.W. 2164
AU - Sydney
Phone: +61 (0) 2 97 56 23 22
Fax: +61 (0) 2 97 56 48 92, 97 56 14 92
E-mail: steve@flender.com.au
www.flender.com.au

SALES OFFICES:
Flender (Australia) Pty. Ltd.
Suite 3, 261 Centre Rd.
AU - Bentleigh, VIC, 3204 Melbourne
Phone: +61 (0) 3 - 95 57 08 11
Fax: +61 (0) 3 - 95 57 08 22
E-mail: ernie@flender.com.au

Flender (Australia) Pty. Ltd.
Suite 5 - 1407 Logan Rd.
Mt. Gravatt
AU - QLD 4122 Brisbane
Phone: +61 (0) 7 34 22 23 89
Fax: +61 (0) 7 34 22 24 03
E-mail: johnw@flender.com.au

Flender (Australia) Pty. Ltd.
Suite 2 403 Great Eastern Highway
AU - W.A. 6104, Redcliffe, Perth
Phone: +61 (0) 8 94 77 41 66
Fax: +61 (0) 8 94 77 65 11
E-mail: paulj@flender.com.au

NEW ZEALAND

Please refer to Flender (Australia) Pty. Ltd.
9 Nello Place, P.O. Box 6047
Whetherill Park,
AU - N.S.W. 2164, Sydney
Phone: +61 (0) 2 97 56 23 22
Fax: +61 (0) 2 97 56 48 92 / 97 56 14 92
E-mail: steve@flender.com.au

12. Declaration by the manufacturer

Declaration by the manufacturer

in accordance with EC Engineering Guideline 98/37/EC, Appendix II B

We hereby declare that the

Escalator gear units of Types **CG35-125, CG19-160, CRW160**

described in these Operating Instructions are intended for incorporation in a machine, and that it is prohibited to put them into service before verifying that the machine into which they are incorporated complies with the EC Guidelines (original edition 98/37/EC including any subsequent amendments thereto).

This Manufacturer's Declaration takes into account all the unified standards (inasmuch as they apply to our products) published by the European Commission in the Official Journal of the European Community.



Bocholt, 2002-12-04

Signature (person responsible for products)