

Operating Instructions

BA 6801 EN 10.02

Lift Drive Type
CG 45
Size 120

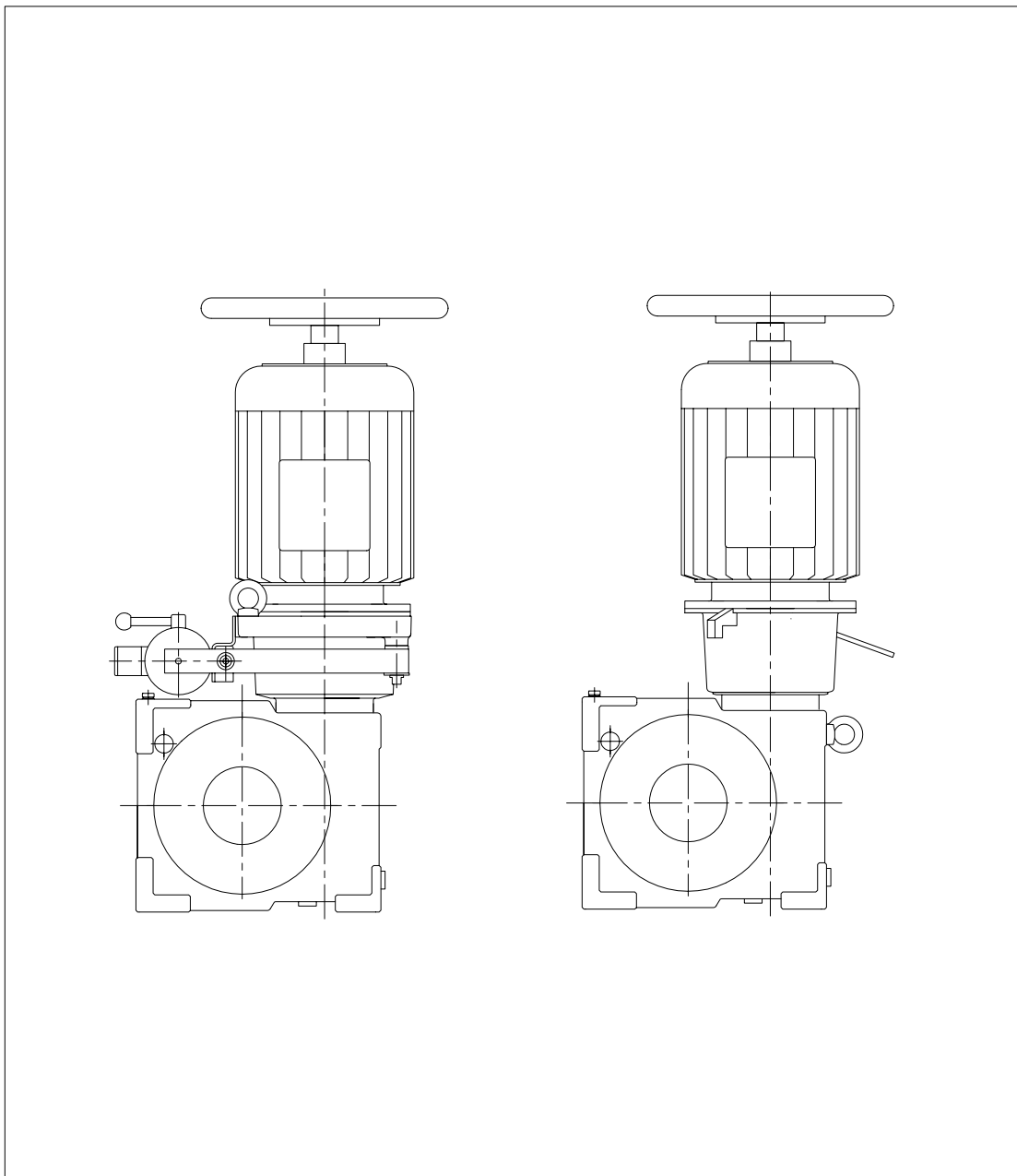

FLENDER

1.	Technical data	4
1.1	General technical data	4
1.1.1	Gear unit nameplate	4
1.1.2	Motor nameplate	4
1.1.3	Brake nameplate	4
1.2	Weights	5
1.3	Oil quantity	5
1.4	Measuring-surface sound level	5
2.	General notes	6
2.1	Introduction	6
2.2	Copyright	6
3.	Safety notes	7
3.1	Proper use	7
3.2	Obligations of the user	7
3.3	Environmental protection	8
3.4	Special dangers	8
3.5	Warnings and symbols used in these Instructions	8
4.	Handling and storage	8
4.1	Scope of supply	8
4.2	Handling	8
4.3	Storing the drive	9
4.4	Standard corrosion protection	9
5.	Technical description	10
5.1	General description	10
5.2	Three-phase motor	10
5.3	Coupling	10
5.4	Brake	10
5.4.1	Gear unit with dual-circuit disk brake	10
5.4.2	Gear unit with double-shoe brake	10
5.5	Gear unit	10
5.6	Traction sheave	11
5.7	Emergency brake	11
6.	Assembly	12
6.1	General information on installation	12
6.2	Mounting surface	12
6.3	Description of installation work	13

7.	Start-up	14
7.1	Oil filling	14
7.1.1	Gear unit with oil filling	14
7.1.2	Gear unit without oil filling	14
7.2	Breather	14
7.3	Connecting the motor, PTC resistors and the incremental transmitter	15
7.4	Brake connection	15
7.4.1	Dual-circuit disk brake	16
7.4.2	Double-brake shoe and switch	16
7.4.2.1	Connection diagram of the switches for wear monitoring	16
7.4.2.2	Connection diagram of switches for function check (brake on/off)	17
7.4.3	Emergency brake and switch	17
7.5	Instructions for the brake function test	18
7.5.1	Dual-circuit disk brake	18
7.5.2	Double-shoe brake	18
7.5.3	Emergency brake	18
8.	Operation	18
8.1	General operating data	18
9.	Faults, causes and remedy	19
9.1	Possible faults on the gear unit	19
9.2	Possible faults on motor	20
9.3	Possible faults on the dual-circuit disk brake	20
9.4	Possible faults on the double-shoe brake	21
9.5	Possible faults on emergency brake	21
10.	Maintenance and repair	22
10.1	General notes on maintenance	22
10.2	Description of maintenance and repair work	23
10.2.1	Changing the oil	23
10.2.2	Cleaning the venting screw	23
10.2.3	Clean drive	23
10.2.4	Checking tightness of fastening bolts	23
10.2.5	Change rotor of dual-circuit disk brake	24
10.2.6	Adjust braking torque on the double-shoe brake	25
10.2.7	Check residual stroke on brake lifting device	25
10.2.8	Set switch points on the monitoring switches	26
10.2.9	Check wear on brake linings	26
10.2.10	Change brake shoes	26
10.2.11	Set lifting gap on the emergency brake	27
10.3	Lubricants	28
10.3.1	Oil types	28
10.3.2	Oil change	28
11.	Spare parts, customer-service addresses	30
11.1	Stocking spare parts	30
11.2	Spare-part and customer service addresses	30
12.	Declaration by the manufacturer	35
12.1	EC Type Test Certificate for emergency brake	36
12.2	Annex to EC Type Test Certificate for emergency brake	37

1. Technical data

1.1 General technical data

The nameplates to the individual component assemblies show the following technical data.

They show the most important technical data. These data together with the contractual agreements determine the limits of its proper use.

A differently designed nameplate may be fitted by special arrangement.

1.1.1 Gear unit nameplate

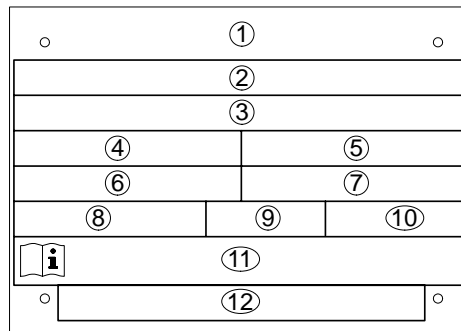

- | | |
|--|---------------------------------|
| ① Company logo and production location | ⑦ Speed n_2 |
| ② Special information | ⑧ Type of oil |
| ③ Order no. - item - serial no. | ⑨ Viscosity of oil in VG class |
| ④ Type / Size | ⑩ Quantity of oil in litres |
| ⑤ Torque T_2 in Nm | ⑪ Operating Instructions number |
| ⑥ Speed n_1 | ⑫ Special information |

For further technical data, refer to the drawings in the gear-unit documentation.

1.1.2 Motor nameplate

The motor nameplate shows the following data:

Type, serial number, speed, output or torque, voltage, frequency and current.

1.1.3 Brake nameplate

The brake nameplate shows the following data:

Type, voltage and braking torque.

1.2 Weights

The weight of the complete drive, including size 132 motor, brake, coupling and oil filling, but without traction sheave and without emergency brake, is approx. 165 kg.
With drives with emergency brake the total weight is approx. 200 kg.

1.3 Oil quantity

The oil quantity to be filled into the gear unit is approx. 6.4 litres and applies for the "Motor vertical" and "Motor horizontal" mounting positions.

1.4 Measuring-surface sound level

The measuring-surface sound-pressure level for the drive at a distance of 1 m is shown in table 1.4.

Measurement is carried out to DIN 45 635 Parts 1 and 23 by the sound-intensity method and at at least 30 % rated output.

The workplace of the operating personnel is defined as the area on the measuring surface at a distance of 1 metre from the drive in the vicinity of which persons may be present.

The sound-pressure level applies to drives that have run warm and at the speeds indicated in Table 1.4.

If repeat measurements on site do not produce conclusive results with regard to measuring technology, the measurement obtained on the FLENDER test bench will apply.

The sound-pressure levels stated in the table were obtained by statistical calculation by our Quality Control Dept. The drives can be statistically expected to comply with these noise levels.

n_1 1/min	Measuring-surface sound level L_{pA} in dB(A)
2000	70
1500	64
1000	62

Table 1.4: Measuring-surface sound-pressure levels at maximum load and with the largest permissible motor fitted (permissible deviation +3 dB(A)).

Frequency inverter operation can negatively affect the noise.

2. General notes

2.1 Introduction

These operating instructions (BA) are an integral part of the drive supplied and must be kept in its vicinity for reference at all times.

Caution!

All persons involved in the installation, operation, maintenance and repair of the drive must have read and understood these operating instructions and must comply with them. We accept no responsibility for damage or disruption caused by disregard of these Instructions.

The drive described here has been manufactured in compliance with the recognised safety regulations and the state of technical development applying at the time these operating instructions were printed.

In the interest of technical progress we reserve the right to make changes to the individual assemblies and accessories which we regard as necessary to preserve their essential characteristics and improve their efficiency and safety.

2.2 Copyright

The copyright to these operating instructions is held by **FLENDER GMBH**.

These Operating Instructions must not be wholly or partly reproduced for competitive purposes, used in any unauthorised way or made available to third parties without our agreement.

Technical enquiries should be addressed to the following works

A. FRIEDR. FLENDER GMBH

D-46393 Bocholt

Tel.: 02871/92-0

Fax: 02871/92-2596

or to one of our customer-service addresses. A list of our customer-service addresses is given in section 11, "Spare parts, customer-service addresses".

3. Safety notes

3.1 Proper use

- The drive has been manufactured in accordance with the state of the art and is delivered in a condition for safe and reliable use. All changes to the gear unit on the part of the user which may affect its safety and reliability are prohibited.
This applies equally to safety features designed to prevent accidental contact.
- The drive must be used and operated strictly in accordance with the conditions laid down in the contract governing performance and supply.

3.2 Obligations of the user

- The user must ensure that all persons involved in the installation, operation, maintenance and repair of the gear unit have read and understood these Operating Instructions and comply with them at all times in order to:

- avoid injury or damage,
- ensure the safety and reliability of the drive,

and

- avoid disruptions and environmental damage through incorrect use.
- During transport, assembly, installation, dismantling, operation and maintenance of the unit, the relevant safety and environmental regulations must be complied with at all times.
- The drive must be operated, maintained and repaired only by authorised, properly trained and qualified personnel.
- The gear unit must not be cleaned using high-pressure cleaning equipment.
- All work on the gear unit must be carried out with great care and with due regard to safety.
- All work on the drive must be carried out only when it is not in operation.
The drive unit must be secured against being switched on accidentally (e.g. by locking the key switch or removing the fuses from the power supply). A notice should be attached to the start switch stating clearly that work is in progress on the drive.
- No welding work must be done on the drive.
The drives must not be used as an earthing point for welding operations. Toothed parts and bearings may be irreparably damaged by welding.
- If any changes (e.g. overheating or unusual noises) are noticed on the drive during operation, the drive unit must be switched off immediately.
- Rotating drive components such as traction sheaves and hand wheels must be fitted with suitable safeguards to prevent contact.
- If the drive is intended for installation in plant or machinery, the manufacturer of such plant or machinery must ensure that the contents of these operating instructions are incorporated in his own instructions.
- Notices such as nameplates etc. attached to the drive must be observed. They must be kept free from dirt and paint at all times. Missing plates must be replaced.
- All spare parts must be obtained from FLENDER.

3.3 Environmental protection

- When changing oil, the used oil must be collected in suitable containers. Any spillage of oil must be removed immediately.
- Used oil, preservative agent, oil-binding agents and oil-soaked cloths must be disposed of in accordance with environmental legislation.

3.4 Special dangers

- Depending on operating conditions, the surface of the drive may heat up considerably.
Danger of burns!
- When changing oil, take care to prevent scalding by hot oil.

3.5 Warnings and symbols used in these Instructions



This symbol indicates safety measures which must be observed to avoid **personal injury**.

Caution!

This symbol refers to safety measures which must be observed to avoid **damage to drive components**.

Note:

This symbol indicates general **operating instructions** which are of particular importance.

4. Handling and storage

Note: Observe the "Safety instructions" in section 3.

4.1 Scope of supply

The products supplied are listed in the despatch papers. Check immediately on receipt to ensure that all the products listed have actually been delivered. Parts damaged during transport or missing parts must be reported in writing immediately.

4.2 Handling



When handling FLENDER products, use only lifting and handling equipment of sufficient load-bearing capacity!

Different forms of packaging may be used, depending on the size of the drive and method of transport. Unless otherwise agreed, the packaging complies with the **HPE Packaging Guidelines**.

The symbols marked on the packaging must be observed at all times. These have the following meanings:

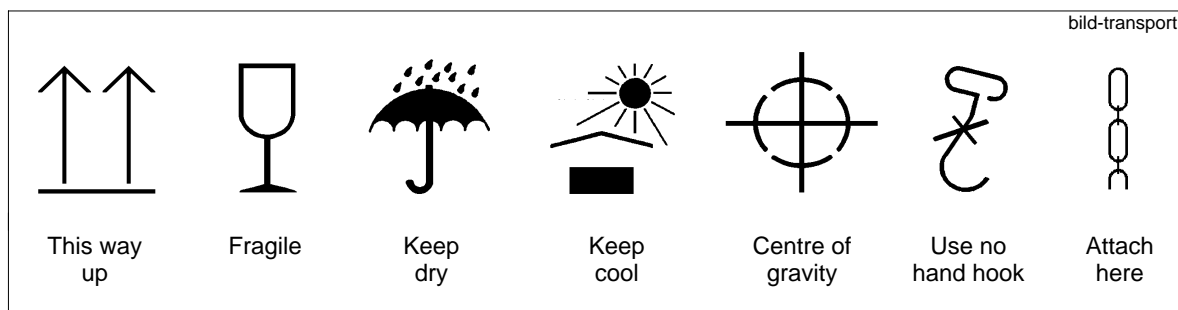

Caution!

The drive must always be transported and handled with due care to avoid damage to persons and the drive. If, for example, the free shaft ends are knocked, this may damage the drive.

Note: The drive must be transported and handled with suitable equipment only.

Note: If the gear unit is filled with oil, the rating plate will show the following information:
Filled with oil.

Caution!

**Use only the eyes provided to transport and handle the drive.
Do not use the front threads at the shaft ends to attach eye bolts for transport.**

Caution!

During transport and handling care must be taken not to damage the hand wheel. Ropes or chains must not come in contact with the hand wheel during transport and handling.

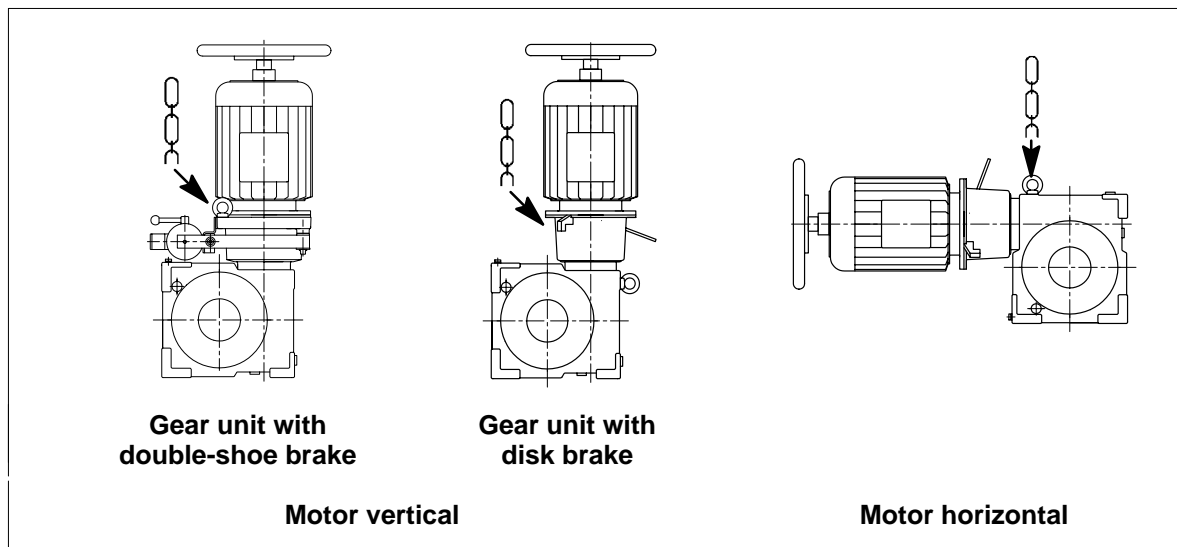

4.3 Storing the drive

The drive must be stored in the position of use on a vibration-free wooden base in a sheltered place and covered over.

Caution!

If the drive is being stored out of doors, it must be very carefully covered over and care must be taken that neither moisture nor foreign material can collect on the drive.

Note: Provision for special environmental conditions during transport (e.g. transport by ship) and storage (climate, termites, etc.) must be contractually agreed.

4.4 Standard corrosion protection

The gear unit has been initially filled with synthetic oil (long-term lubrication) by us.

Note: If initial filling has not been expressly agreed, the internal parts of the gear unit are treated with preservative. This preservative is sufficient for normal transport conditions (including overseas transport) and for a period of 6 months until initial start-up.

The outer paint coating is resistant to dilute acids, alkalis, oils and solvents. It is also resistant to sea water, tropical conditions and temperatures up to 140 °C.

The shaft ends have been provided with a rust-preventive paint coating. It is resistant to seawater and tropical conditions for a period of 12 months.

Note: Ensure that the paint is not damaged!
Mechanical damage (scratches), chemical damage (acids, alkalis) and thermal damage (sparks, welding beads, heat) cause corrosion which may cause failure of the external protective coating.

For longer periods of storage (> 24 months) we advise regular checking and, if necessary, renewal of the internal and external preservative (see section 7, "Start-up").

5. Technical description

Note: Observe the "Safety instructions" in section 3.

5.1 General description

The worm-gear unit and the traction sheave located on the output shaft are driven by a three-phase motor via a flexible coupling.

A brake is fitted to the gear unit to brake and stop the load.

5.2 Three-phase motor

Drive is provided by a three-phase motor which is usually fitted with a hand wheel. An incremental transmitter for monitoring the speed is located under the hand wheel.

The motor is normally provided with PTC resistors to signal thermal overload. The PTC resistors are wired to the terminal box of the motor.

A trip device (motor protection device) is required to evaluate a signal from the PTC resistors.

5.3 Coupling

The flexible coupling located between the motor and the gear unit requires no maintenance. On gear units with a double-shoe brake the coupling part on the gear-unit side is designed as a brake disk. On gear units with a dual-circuit disk brake the coupling part on the gear-unit side is provided with splines to receive the brake rotor.

5.4 Brake

Depending on the application, the drive is equipped with a dual-circuit disk brake or a double-shoe brake.

5.4.1 Gear unit with dual-circuit disk brake

The brake is used as a blocking brake and has a fixed braking torque. The brake is provided with manual lifting device and a plug for connecting the electric brake lifting device.

5.4.2 Gear unit with double-shoe brake

This brake can also be used as a service brake.

The braking torque is adjustable.

The brake is fitted with an electrically operated brake lifting device and a hand lifting lever. The electrical connection is made on the terminal box of the brake lifting device.

The brake can be provided with two switches to monitor brake wear or function (brake on/off).

5.5 Gear unit

It is outstanding for its quiet running and high efficiency.

Caution!





**With transmission ratios up to 25.5 the gear unit is not self-locking.
With larger transmission ratios the gear unit can be self-locking.**

All toothed gear-unit parts and rolling bearings are adequately supplied with oil by dip lubrication.

The gear unit is provided with the necessary inspection and fitting holes.

FLENDER

Colour codes for venting, oil inlet, oil level and oil drainage:

Breather:	yellow	
Oil inlet:	yellow	
Oil level:		
Oil drain:	white	



5.6 Traction sheave

The traction sheave is delivered separately. The associated cable clamp is enclosed with the traction sheave.

5.7 Emergency brake

As a protection against excess speed, an emergency brake with fixed braking torque can be fitted to the side opposite the output (crash protection).

For normal operation, the brake must be used as a static brake, so there will be no appreciable wear. Dynamic braking occurs only during testing or in emergency. If the speed of the lift car is too high, a signal to brake is emitted by the control system (not supplied by us). The lifting current is interrupted on the brake, and the brake is applied.

In the currentless condition the brake can be lifted with two screws (see also item 10.2.11).

Caution!

This brake lifting device is permitted only to evacuate the lift car if the power fails. Care must be taken that the lift cannot be operated electrically during the entire lifting time.

The brake may be lifted only by an authorised person.

After brake lifting has finished, the lifting screws must be removed from the brake.

The electrical connection is made with a plug supplied with the drive. The brake is provided with a switch to check the function (brake on/off).

6. Assembly

Note: Observe the "Safety instructions" in section 3.

6.1 General information on installation

Assembly and installation work must be done with great care by trained and qualified personnel. The manufacturer cannot be held liable for damage caused by incorrect assembly and installation.

During the planning phase sufficient space must be left around the drive for later care and maintenance work.

Adequate lifting equipment must be available before beginning the installation and assembly work.

Caution!

**No welding work must be done on the drive.
The drives must not be used as an earthing point for welding operations.
Toothed parts and bearings may be irreparably damaged by welding.**

Caution!

All the fastening points provided by the design of the unit must be used.

The air feed for cooling the drive must not be impaired.

A means of monitoring the oil level must be provided.

6.2 Mounting surface

The mounting surface must be horizontal or vertical and even.

The perm. unevenness is 0.2 mm.

The mounting surface is rigid and robust enough to withstand the forces set up.

6.3 Description of installation work

- Remove anti-corrosive paint on the shafts and connecting surfaces with cleaning medium

Caution!

The cleaning medium must not be allowed to come in contact with the shaft sealing rings.



Ensure adequate ventilation. Do not smoke!
Danger of explosion!

- Stand gear unit on the mounting surface and fasten down.

Fastening bolts or nuts must be tightened to the prescribed torque. For the correct torque, refer to item 10.2.4. Bolts of the minimum strength class 8.8 must be used.

- Screw the mountings for the cable safety device on in the correct position for the cable safety requirement.
- Mount the traction sheave on the output shaft and secure with the end plate.

Hexagon bolts and nuts should be tightened to the specified torque. For the correct torque, refer to item 10.2.4. The screws delivered with the unit are of strength class 8.8.

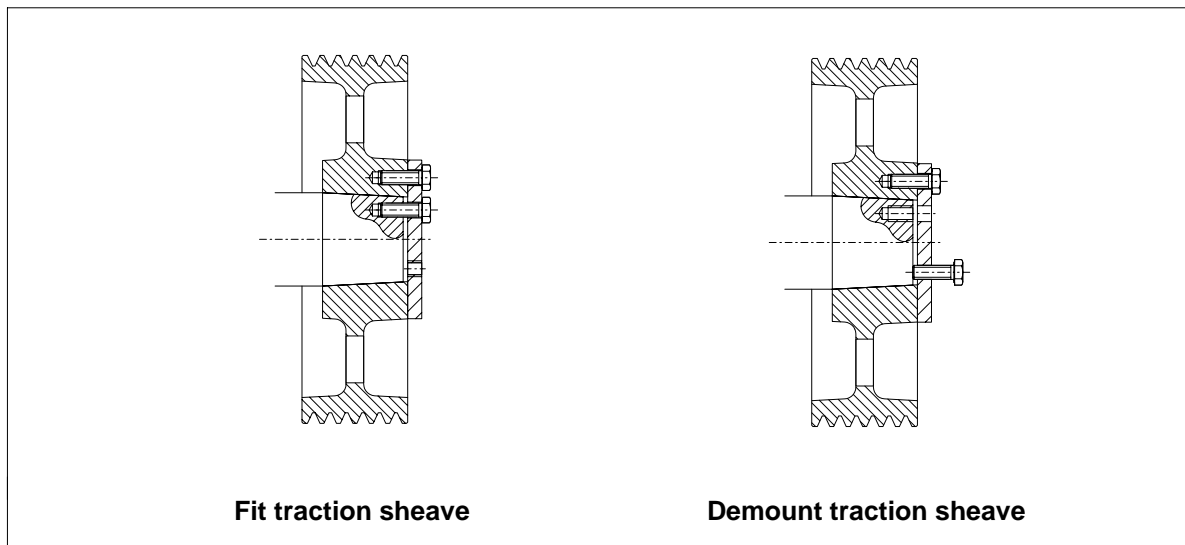
**Caution!**

Never use force or knock the couplings into position, as this may damage the rolling bearings, locking rings, etc.

- Fit safety equipment such as cable safety device and cable guard.

7. Start-up

Note: Observe the "Safety instructions" in section 3.

Caution!

On drives without speed control the brake on the input side must be fitted with switches to monitor wear (residual travel monitoring).

7.1 Oil filling

Caution!

Check the oil level before starting up. The oil must be up to the middle of the sight glass at least or up to the upper edge of the sight glass at most.

Caution!

Before starting up, the upper screw plug (marked yellow) must be replaced with the breather screw supplied separately.

7.1.1 Gear unit with oil filling

In this case the gear unit is filled with synthetic lubricant (polyglycol) by us before despatch.

Note: The rating plate shows the information: **Filled with oil.**

7.1.2 Gear unit without oil filling

If the drive has been delivered without an oil filling, the gear unit must be filled with oil up to the middle of the oil sight glass at least or up to the upper edge of the sight glass at most, before starting up.

The oil quantity indicated on the rating plate is a reference value.

Various lubricants are indicated in the lubricant table (see section 10) according to the oil manufacturers' recommendations. Equivalent brands of non-foaming oil by other manufacturers may also be used. It is important to use the type of oil (synthetic or mineral oil) specified on the nameplate.

However, we cannot guarantee that a selected lubricant is completely suitable.

The oil selected for use in the gear unit must be of the viscosity (VG class) indicated on the nameplate.

7.2 Breather

On starting up care must be taken that the breather screw with its seal is fitted.

7.3 Connecting the motor, PTC resistors and the incremental transmitter

Circuit diagrams showing how the motor and, if provided, the PTC resistors and incremental transmitter must be connected up are located in the motor terminal box.

Caution!

Connection must be carried out by a specialist in accordance with the current safety regulations. The relevant installation and operating requirements and the usual national and international requirements must be observed.

- Observe information on rating plate!
- Note wiring!
- Observe rating current for safety switch setting!

Note: The motor must be protected against overheating e.g. with a motor safety switch.

- The cross-sectional areas of the feed lines must be adapted to fit the rating current.
- Provide pull-relief for the connecting leads.
- Ensure that the non-fused earth conductors to DIN VDE 0100 are connected to the marked earth conductor terminal.
- When closing the terminal box, use the seal originally provided.
- Seal unused inlet holes to prevent entry of dust and water.

Caution!

Voltages higher than 2.5 V must not be applied to the PTC-resistors.

- Before starting up, the insulation resistance of the winding must be measured phase to phase and phase to earth.
- Damp windings can result in creep currents, flashovers and blowouts. The insulation resistance of the stator winding must be at least 1.5 megohm on motors for 220 – 1000 V at a winding temperature of 20 °C. If values are lower, the winding must be dried.



Check before start-up:

Observe information on rating plate!

Check whether voltage and frequency of the motor correspond to the mains supply values!

Check that the motor is properly protected!

Check that the electrical connections are properly tightened and the monitoring equipment is properly connected and set!

Check that air inlet holes and cooling surfaces are clean!

Check that protective measures have been taken! **EARTH!**

Check that the terminal box cover is closed and the line inlets are properly sealed!

7.4 Brake connection

Caution!

Connection must be carried out by a specialist in accordance with the current safety regulations. The relevant installation and operating requirements and the usual national and international requirements must be observed.

Note: The data indicated on the nameplate must be observed!

7.4.1 Dual-circuit disk brake

Technical data to the brake:

Braking torque	2x30	Nm
Rated voltage	103,5	VDC
Rated output	86	W
Coil resistance	125	Ω
perm. duty cycle	60	% / 10 minutes

The terminal strip for the brake connection has no PIN designations. The contacts of the mating connector must be laid out so that respectively opposing PINs are connected. The kind of polarity is unimportant. Normally the brake is switched on the AC side. If it is switched from the DC side, a protective circuit (recovery diode) is required. Increased switching noise must be expected.

7.4.2 Double-brake shoe and switch

Technical data to the brake and the switch:

Braking torque	2x70	Nm
Coil voltage	205	VDC
Coil resistance	2 x 412	Ω
Input voltage	230	VAC (+6% / -10%), 50/60 Hz
Rated output	92	W
Rated current	0,47	A
perm. duty cycle	60	% / 10 minutes
Switch: perm. voltage	230	VDC
perm. current	4	A

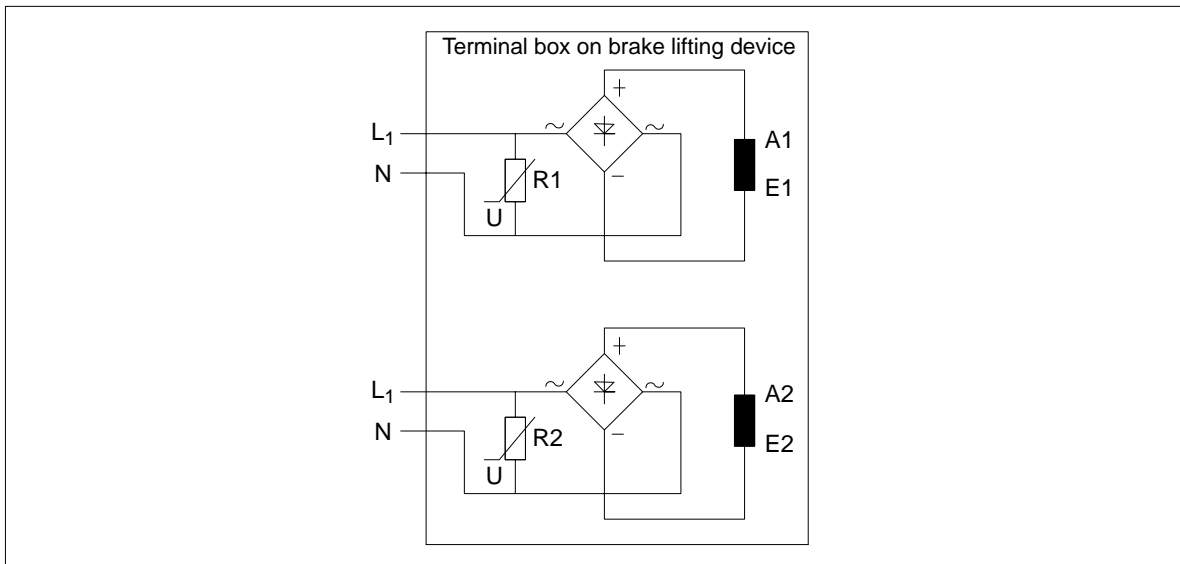

7.4.2.1 Connection diagram of the switches for wear monitoring

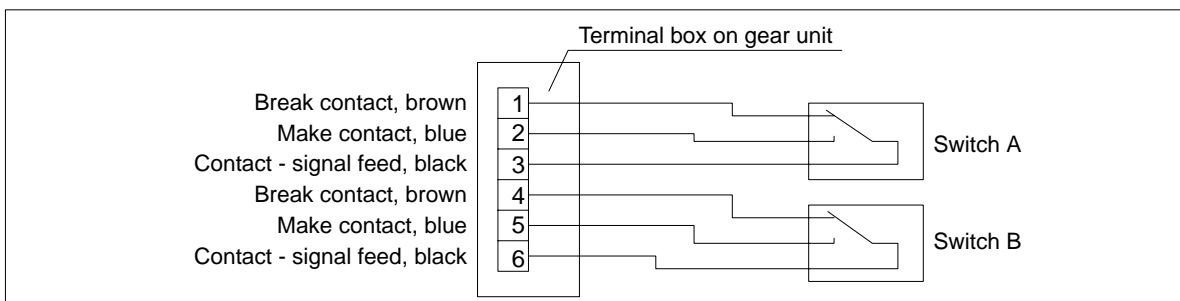

Switch shown in rest position - it operates when minimum residual stroke = 1.4 mm is reached.

7.4.2.2 Connection diagram of switches for function check (brake on/off)

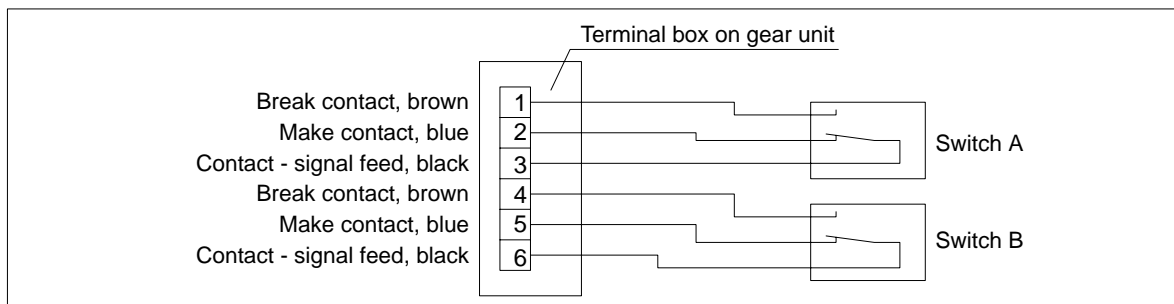

Switch position for braked condition - when the brake is lifted, the switch changes to the rest condition.

7.4.3 Emergency brake and switch

Technical data to the brake and the switch:

Braking torque	800	Nm	
Overexcitation voltage	207	VDC	for 1-1.5 sec.
Holding voltage	103.5	VDC	+5% / -10%
Coil output with overexcitation	302	W	
Coil output with holding voltage	76	W	
Coil resistance	142	Ω	
perm. ambient temperature	40	$^{\circ}\text{C}$	
perm. duty cycle	60	% / 10 minutes	
Switch: perm. voltage	24	VDC	
perm. current	10-100	mA	

Terminal connection diagram

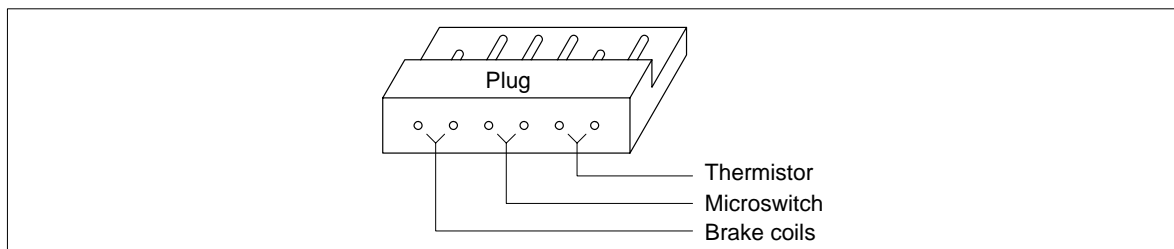

Microswitch

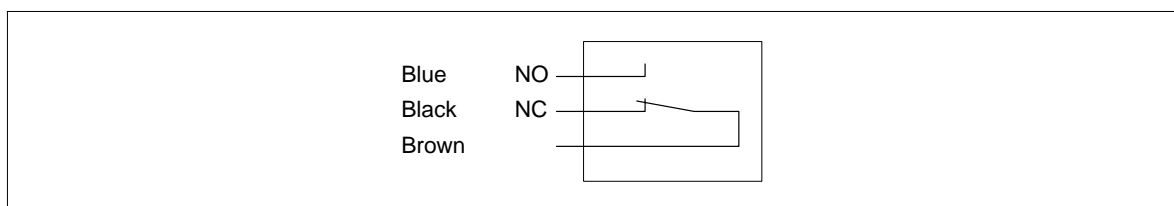

When the coil is currentless (brake engaged), the switch is in the NC position.

In normal operation the drive is braked by motor control. Only when the drive has come to a complete standstill may the brake be applied. Before the motor is restarted, the brake must be lifted.

Normally the brake is switched from the AC side. If it is switched from the DC side, a protective circuit (recovery diode) is required. Increased switching noise must be expected.

If the speed limiter acts (emergency), the braking voltage must be switched off on the DC side (shorter brake application time).

Before start-up the lifting screws (see item 10.2.11) must be removed from the brake.

For operation of the brake the safety regulations for the design and installation of lifts to DIN EN 81-1 and the EC Type Test ABV 603 of the TÜV South Germany must be observed (see section 12).

7.5 Instructions for the brake function test

7.5.1 Dual-circuit disk brake

Design of the brake:	electrically single-circuit mechanically dual-circuit		
electrical test:	power off	⇒	brake closed
	power on	⇒	brake open
mechanical test:	push both lifting levers	⇒	brake open
	push each lifting lever	⇒	brake closed

7.5.2 Double-shoe brake

Design of the brake:	electrically dual-circuit mechanically dual-circuit		
electrical test:	power off for both coils	⇒	brake closed
	power on for one coil	⇒	brake closed
	power on for both coils	⇒	brake open
mechanical test of each brake circuit:			
lift brake electrically, lock one brake lever, power off			
lifting lever not pushed		⇒	brake closed
push lifting lever		⇒	brake open

7.5.3 Emergency brake

Design of the brake:	electrically single-circuit mechanically dual-circuit		
electrical test:	power off	⇒	brake closed
	power on	⇒	brake open
mechanical test:	screw in lifting screws	⇒	brake open

8. Operation

Note: Observe the "Safety instructions" in section 3.

8.1 General operating data

During operation of the drive watch for:

- excessive operating temperature
- unusual noises
- possible oil spillage

Caution!

If any irregularities are noticed during operation, switch the drive unit off at once. Determine the cause of the fault, using the table in section 9.

This table contains a list of possible faults, their causes and suggested remedies.

If the cause cannot be identified or the unit repaired with the facilities available, you are advised to contact one of our customer-service offices for specialist assistance (see section 11).

9. Faults, causes and remedy

Note: Observe the "Safety instructions" in section 3.

Note: Faults and malfunctions occurring during the guarantee period and requiring repair work on the drive must be carried out only by FLENDER Customer Service. In the case of faults and malfunctions occurring after the guarantee period and whose cause cannot be precisely identified we advise our customers to contact our customer service.

Caution!

FLENDER cannot guarantee or otherwise be responsible for further operation of the drive, if the drive is put to improper use, modifications are carried out without FLENDER's agreement or spare parts not supplied by FLENDER are used.



When remedying faults and malfunctions, the drive must be taken out of service.

Secure the drive unit to prevent it from being started up unintentionally. Attach a warning notice to the start switch.

Caution!

With transmission ratios up to 25.5 the gear unit is not self-locking. With larger transmission ratios the gear unit can be self-locking.

9.1 Possible faults on the gear unit

Malfunctions	Causes	Remedy
Changes in gear noise	Damage to gear teeth	Contact Customer Service.
	Excessive bearing play	Contact Customer Service.
	Bearing defective	Contact Customer Service.
	Fastening has worked loose	Tighten bolts / nuts to prescribed torque. See item 10.2.4. Replace damaged bolts / nuts.
Operating temperature too high	Oil level in gear-unit housing too high or too low	Check the oil level at room temperature and, if necessary, adjust oil level
	Oil too old	Change oil. See section 10.
	Oil badly contaminated	Change oil. See section 10.
	Bearing defective	Contact Customer Service.
Circumferential backlash on the traction sheave too high	Wear on worm gear	Contact Customer Service.
	Excessive bearing play	Contact Customer Service.
Oil leakage from gear unit	Radial shaft sealing rings defective	Replace radial shaft sealing rings

9.2 Possible faults on motor

Malfunctions	Causes	Remedy
Excessive running noise	Bearing defective	Contact Customer Service.
	Hand wheel defective	Replace hand wheel.
	Incremental transmitter defective	Replace incremental transmitter.
Excessive bearing temperature	Bearing defective	Contact Customer Service.
Motor will not start	Mains voltage too low	Check mains conditions.
	Phase break	Check connections.
Motor getting too hot	Fan suction hole fouled up	Clean fan cover.
Protective device trips	Phase break	Check connections.
	Winding or terminal short-circuit	Check insulation resistance.

9.3 Possible faults on the dual-circuit disk brake

Malfunctions	Causes	Remedy
Brake does not lift	incorrect voltage applied	apply correct voltage
	rectifier defective	replace rectifier
	lifting gap too large	change brake rotor (see 10.2.5). 1)
	brake coil defective	Contact Customer Service.
Brake does not operate	power supply not interrupted	check switch
	friction surfaces dirty	change brake rotor (see 10.2.5).

- 1) Increasing the lifting gap to suit the new conditions will result in increased switching noise. With excessive switching noise it may also be necessary to change the rotor before reaching a lifting gap of 1.2 mm.

9.4 Possible faults on the double-shoe brake

Malfunctions	Causes	Remedy
Brake travel too short or too long	Brake not properly adjusted	Alter braking torque. See item 10.2.6.
Switches for wear monitoring emit signal	Wear on brake linings	Re-adjust brake. See item 10.2.8 and 10.2.9.
Brake will not lift, motor will not start	Brake lifting device defective	Contact Customer Service.
Brake lifts on one side only	Brake lifting device not properly connected up	Check connections.
	Brake lifting device defective	Contact Customer Service.
Brake does not operate	power supply not interrupted	check switch
	friction surfaces dirty	change brake shoes (see 10.2.10).

9.5 Possible faults on emergency brake

Malfunctions	Causes	Remedy
Brake does not lift	incorrect voltage applied	apply correct voltage
	lifting gap too large	adjust lifting gap (see 10.2.11)
	brake motor worn	Contact Customer Service.
	brake coil defective	Contact Customer Service.
Brake does not operate	power supply not interrupted	check switch
	friction surfaces dirty	Contact Customer Service.

10. Maintenance and repair

Note: Observe the "Safety instructions" in section 3.

10.1 General notes on maintenance

Note: Maintenance and repair work must be done with care by trained and qualified personnel only.
Adherence to the inspection intervals is part of the guarantee conditions.

Measures	Periods	Remarks
Check gear-unit temperature	monthly	permiss. 80 °C on housing, for higher temperatures, see item 9.1
Check for unusual gear-unit noise	monthly	if changed, see item 9.1.
Check oil level	monthly	Oil level at least up to middle of oil sight glass or at most up to upper edge of oil sight glass
Check gear unit for leaks	monthly	
First oil change after start-up	after approx. 1000 (300) operating hours, but at latest after 5 years (18 months)	see item 10.2.1
subsequent oil changes	after approx. 6000 (2000) operating hours, but at latest after 5 years (18 months)	see item 10.2.1
Cleaning the venting screw	simultaneously with oil change	see item 10.2.2
Clean drive	simultaneously with oil change	see item 10.2.3
Checking tightness of fastening bolts	simultaneously with oil change	see item 10.2.4
Check circumferential backlash on traction sheave	yearly	Permissible are 3 mm on a 260 mm traction sheave radius (for higher circumferential backlash, see item 9.1).
Dual-circuit disk brake check lifting gap	yearly	perm. lifting gap 1.2 mm see item 10.2.5
Double-shoe brake Check brake linings	with speed control once a year without speed control every 3 months	see item 10.2.9 and 10.2.10
Double-shoe brake Check residual stroke on brake lifting device	with speed control every 3 months without speed control once a month	adjust residual stroke see item 10.2.7 and 10.2.8
Emergency brake check lifting gap	yearly	perm. lifting gap 0.7 mm see item 10.2.11

Table 10.1: Inspection intervals

Note: The times shown in brackets apply to mineral oils.

10.2 Description of maintenance and repair work

10.2.1 Changing the oil

Caution!

When changing the oil, always re-fill the gear unit with the same type of oil. Never mix different types of oil or oils made by different manufacturers. Never mix synthetic oils with mineral-based oils or with other synthetic oils.

Note:

The oil must be drained off immediately after shutting down the drive and while the oil is still warm. The oil must be given sufficient time to drain off in order to remove oil sludge, abraded metal and oil residues. If iridescent abraded bronze particles appear in the oil, this is not in any way harmful.



There is a danger of scalding from the hot oil emerging from the housing. Wear protective gloves. Remove any oil spillage immediately with an oil-binding agent.

10.2.2 Cleaning the venting screw

The breather screw must be cleaned, if a layer of dust has built up. To do this, the breather screw must be unscrewed, cleaned with benzine or similar agent and dried. It can also be cleaned by blowing out with compressed air.

10.2.3 Clean drive

- Stop the drive by switching off the drive unit



Secure the drive unit to prevent it from being started up unintentionally. Attach a warning notice to the start switch.

- Remove any dirt adhering to the drive with a hard brush.
- Remove any corrosion.

Caution!

The drive must not be cleaned with high-pressure cleaning equipment.

10.2.4 Checking tightness of fastening bolts

- Stop the drive by switching off the drive unit



Secure the drive unit to prevent it from being started up unintentionally. Attach a warning notice to the start switch.

- Check tightness of all fastening bolts with a torque wrench
- Fastening bolts or nuts must be tightened to the prescribed torque. For the tightening torque, see following table.

Tightening torques for bolts and nuts of strength class 8.8				
Thread	M 8	M10	M 12	M 16
Tightening torque (Nm)	25	49	86	210

Note:

Damaged bolts must be replaced with new bolts of the same type and strength class.

10.2.5 Change rotor of dual-circuit disk brake

The brake construction is as shown below.

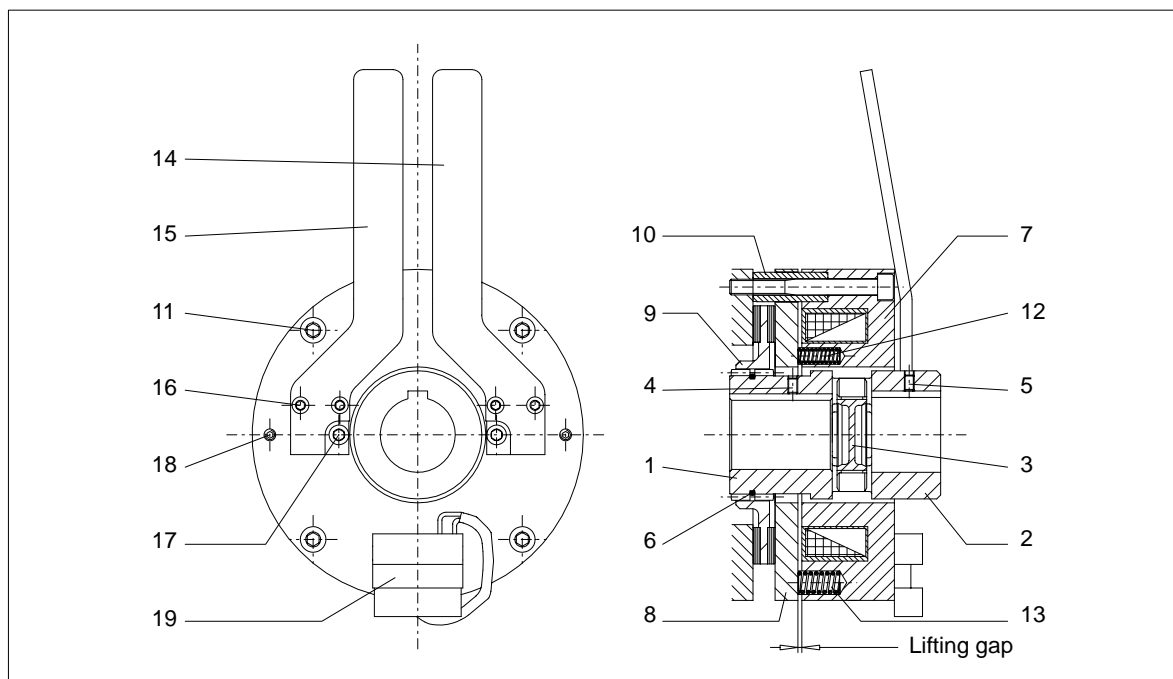

1	Hub 1	8	Armature plate, split	14	Lifting lever 1
2	Hub 2	9	Rotor	15	Lifting lever 2
3	Gear rim	10	Bush	16	Cheese head screw
4	Set screw	11	Cheese head screw	17	Cheese head screw
5	Set screw	12	Pressure spring	18	Damping
6	O-ring	13	Pressure spring	19	Terminal strip
7	Coil bearer				

The brake rotor must be replaced as follows:

- Pull plug out of terminal strip (19)
- Demount motor together with mounted hub (2)
- Remove ring gear (3)
- Undo screws (16) and remove lifting levers (14) and (15)
- Undo screws (11) and pull off brake
- Undo set screw (4) and pull hub with mounted rotor (9) off worm shaft
- Remove rotor (9) from hub (1) and mount new rotor
- Reassemble brake in reverse order

Caution!

The hub (1) must not be hammered or forced onto the worm shaft, as this may damage the rolling bearings.

The following must also be observed:

- Tightening torque of the screws (11) 22 Nm
- Tightening torque of the screws (16) 6 Nm
- Secure screws (16) with metal adhesive
- Check lifting gap - this must be 0.35-0.45 mm
- It must be possible to rotate the rotor (9) free of braking torque with the brake lifted. Check by turning the motor hand wheel

10.2.6 Adjust braking torque on the double-shoe brake

The brake construction is as shown below.

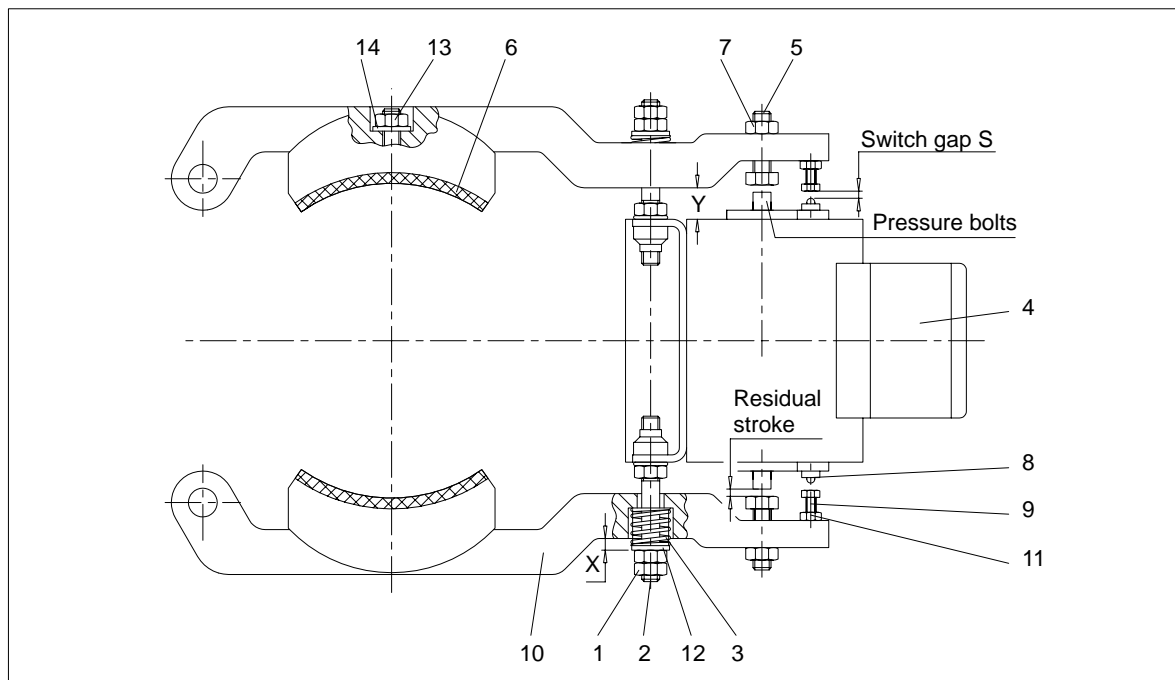

- Switch gap $S = 0.6 \text{ mm}$, if using the switches to monitor wear.
- Switch gap $S = 0$ (switch biased), if using the switches to indicate position.
- Residual stroke: Nominal dimension = 2.0 mm
at least = 1.4 mm

To check the residual stroke, the pressure bolts must be pushed gently, e.g. with a screwdriver, into the brake lifting device.

T_{brak} (Nm)	10	20	30	40	50	60	70
Setting dimension X (mm)	10.2	9.2	8.1	7.0	5.9	4.9	3.9

Wear monitoring: $Y_{\text{min}} = 12.5 \text{ mm}$

The braking torque is raised or lowered by tightening or loosening the adjusting nuts (1) on the drawbars (2).

The max. torque has been reached when the springs (3) are initially tensioned to $x = 3.9 \text{ mm}$.

10.2.7 Check residual stroke on brake lifting device

The residual stroke between brake lifting device (4) and adjusting screws (5) must be 2 mm. The residual stroke is reduced through wear on the brake linings (6). If the residual stroke is reduced (minimum residual stroke = 1.4 mm) the adjusting screw (5) must be reset to a gap of 2 mm and locked with the hexagon nut (7). The setting dimension "X" for initially tensioning the springs (3) by tightening the adjusting nut (1) must be re-adjusted by the same amount as the re-adjustment of the residual stroke.



If no residual stroke is set, brake failure may result!

10.2.8 Set switch points on the monitoring switches

On drives fitted with switches (8) to monitor wear on the brake linings (6), the switch gap must be set as follows after every re-adjustment of the residual stroke:

a) Adjustment with gauge plate

- Screw in adjusting screw (9) until there is an approx. 1 mm gap between it and the switch (8) in brake lever (10).
- Locate 0.6 mm thick gauge plate between switch (8) and adjusting screw (9).
- Screw adjusting screw (9) out as far as the switch point on switch (8).
- Lock adjusting screw (9) with hexagon nut (11).

b) Adjustment without gauge plate

- Screw adjusting screw (9) out as far as the switch point on switch (8).
- Screw adjusting screw (9) back 0.4 of a turn.
- Lock adjusting screw (9) with hexagon nut (11).

If the fitted switches (8) are used to indicate the position of the brake (brake on/off), these must be set as follows:

- Screw in adjusting screw (9) until there is an approx. 1 mm gap between it and the switch (8) in brake lever (10).
- Unscrew adjusting screw (9) without gauge plate as far as the switch point on switch (8).
- Turn adjusting screw (9) a further 0.5 mm (1/3 of a turn) towards switch (8).
- Lock adjusting screw (9) with hexagon nut (11).

10.2.9 Check wear on brake linings

To check the brake linings, dimension "Y" must be checked against the diagram in item 10.2.6.

Note: Dimension "Y_{min.}" must not be less than 12.5 mm.

10.2.10 Change brake shoes

The brake shoes must be changed as follows:

- Unscrew adjusting nut (1) from the drawbar (2).
- Remove thrust piece (12) and springs (3) from brake lever (10).
- Unscrew drawbar (2)
- Swing out brake lever.
- Unscrew hexagon nut (13) and remove disk spring (14)
- Remove brake shoe (6).
- Assemble brake with new brake shoe (6) in reverse order. Secure hexagon nut (13) with metal adhesive.
- Re-adjust braking torque (guide values for adjustment dimension "X" in table, item 10.2.6)
- Adjust residual stroke and switch gaps (see point 10.2.7 and 10.2.8).

10.2.11 Set lifting gap on the emergency brake

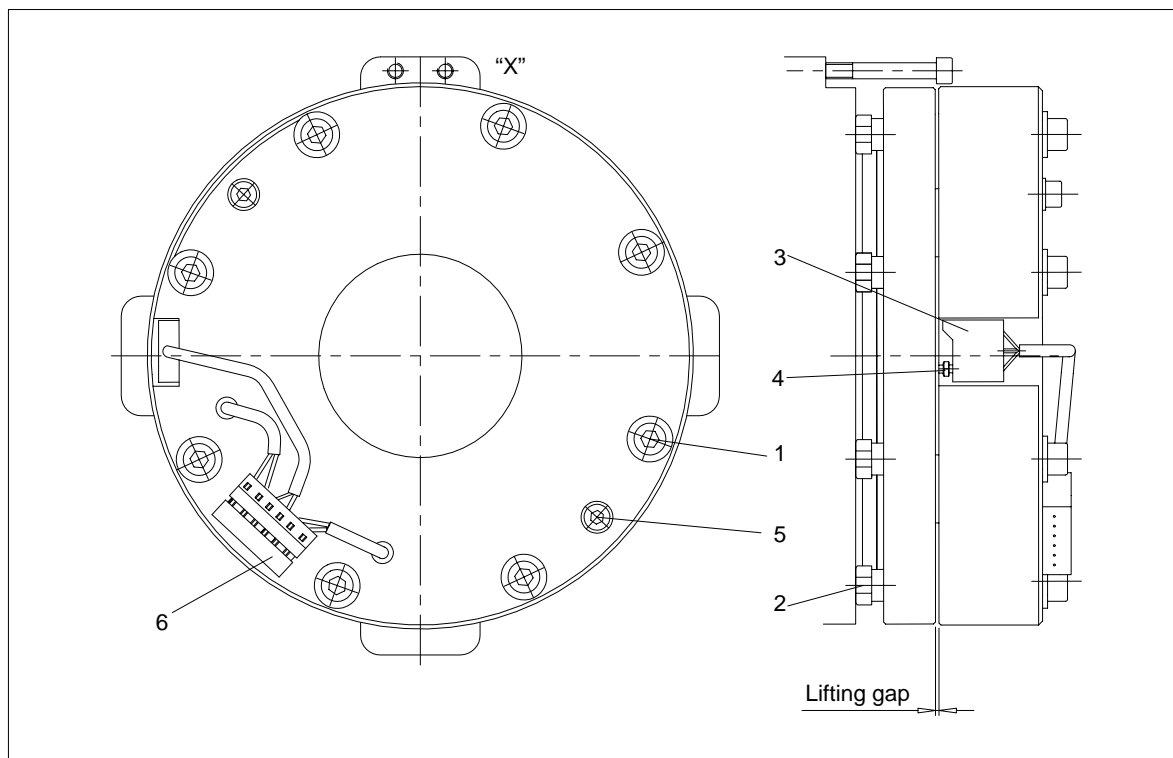

1	Fastening bolt	4	Adjusting screw
2	Adjusting screw	5	Lifting screw M 8 x 70 1)
3	Microswitch	6	Plug

1) If the power supply fails, the brake can be lifted with these screws. (see item 5.7).

Caution!

Before starting up the drive, the screws must be removed from the brake. The screws can be stored by screwing them into the mounting flange at point "X".

Lifting gap: Nominal dimension 0.25-0.35 mm
max. perm. 0.7 mm after wear

The lifting gap increases through wear on the friction linings. Before or at the latest when the lifting gap of 0.7 mm is reached, it must be reset as follows:

- Loosen fastening screws (1) and set lifting gap by shifting the adjusting screws (2) to nominal dimension
- Tighten fastening screws (1) ($T_A = 35 \text{ Nm}$) and check set lifting gap at several points.

After each resetting of the lifting gap the adjusting screw (4) must be readjusted for the operation of the microswitch (3) as follows:

- Insert 0.15 size feeler gauge into the lifting gap in the vicinity of the microswitch (3).
- Put brake under tension
- Screw adjusting screw (4) towards the microswitch (3) as far as the switch point.
- Remove tension on brake
- Remove feeler gauge from lifting gap
- By operating the brake several times check whether microswitch (3) is functioning correctly.

10.3 Lubricants

The oil selected for use in the gear unit must be of the viscosity (VG class) indicated on the nameplate. The viscosity class applies for the contractually agreed operating conditions.

FLENDER must be consulted for any change in operating conditions.

For its gear units, FLENDER approves only CLP oils which contain ingredients to DIN 51517-3 for improvement of corrosion protection, resistance to ageing, and which reduce wear in mixed-friction areas.

Note: For the various makes of oil to be used, refer to the following table.

We therefore advise our customers to select one of the lubricants listed in the table, taking into account the VG class specified on the nameplate.

Note: The use of gear oils which do not comply with the above quality requirements, may invalidate our product guarantee. Every oil manufacturer or supplier of oil is responsible for the quality of his product.

Always select the gear oil in accordance with the viscosity class indicated on the rating plate on the gear unit. If a different viscosity is selected, or oil of a type other than those recommended in these instructions, the operator assumes the responsibility for its technical suitability. In order to minimise the technical risk in such a case, we advise the use of a CLP oil of the above quality which should be accompanied by a statement of suitability by the oil manufacturer.

Caution!

Always comply with the information given on the rating plates and the written instructions for the gear units.

10.3.1 Oil types

- Mineral oils
- Synthetic oils (polyglycol)

The synthetic oils have a wider temperature range and a higher viscosity index (i.e. a flatter viscosity-temperature gradient) than the mineral oils. Guideline values for temperature range:

mineral oils approx. -10 °C to $+90\text{ °C}$ (short term $+100\text{ °C}$);
polyglycols approx. -20 °C to $+100\text{ °C}$ (short term $+110\text{ °C}$).

Note: The upper and lower temperatures (flash point, pour point) for using certain gear oils may deviate widely from the figures indicated. For these and other data and properties of the gear oils, refer to the technical-data sheets published by the oil manufacturers.

10.3.2 Oil change





The degree of purity of the oil affects the operating reliability and life span of the oil and the gear unit. It should therefore be ensured that the oil in the gear unit is clean. Follow the gear-unit instructions regarding the first oil change after start-up as well as for subsequent oil changes.





When changing oil, the quantity of oil remaining in the gear unit should be kept as low as possible. Generally speaking, a small remaining quantity will cause no particular problems. Gear oils of different types and manufacturers must not be mixed. If necessary, the manufacturer should confirm that the new oil is compatible with residues of the old oil. Residues of old oil must be completely removed from the gear unit.





Caution!

Gear oils must never be mixed with other substances. Flushing with paraffin or other solvents is not permitted, as traces of these substances always remain inside the unit.

FLENDER

Lubricant	Viscosity ISO-VG DIN 51519 at 40 °C (mm ² /s)				
Mineral oils (MIN oil)	VG 460	Degol BG 460			Energol GR-XP 460
	VG 220	Degol BG 220			Energol GR-XP 220
Polyglycol (PG oil)	VG 460	Degol GS 460	GEAR VSG 460	BERUSYNTH EP 460	Energol SG-XP 460
	VG 220	Degol GS 220	GEAR VSG 220	BERUSYNTH EP 220	Energol SG-XP 220

Lubricant	Viscosity ISO-VG DIN 51519 at 40 °C (mm ² /s)				
Mineral oils (MIN oil)	VG 460	Falcon CLP 460	SPARTAN EP 460		Klüberoil GEM1 - 460
	VG 220	Falcon CLP 220	SPARTAN EP 220		Klüberoil GEM1 - 220
Polyglycol (PG oil)	VG 460	Polydea PGLP 460	GLYCOLUBE 460	RENOLIN PG 460	SYNTHESO D 460 EP
	VG 220	Polydea PGLP 220	GLYCOLUBE 220	RENOLIN PG 220	SYNTHESO D 220 EP

Lubricant	Viscosity ISO-VG DIN 51519 at 40 °C (mm ² /s)				
Mineral oils (MIN oil)	VG 460	Mobilgear 634 Mobilgear XMP 460	Optigear BM 460		Ersolan 460
	VG 220	Mobilgear 630 Mobilgear XMP 220	Optigear BM 220		Ersolan 220
Polyglycol (PG oil)	VG 460	Mobil Glygoyle HE 460	Optiflex A 460	Shell Tivela SD	
	VG 220	Mobil Glygoyle HE 220 Mobil Glygoyle 30	Optiflex A 220	Shell Tivela WB	

Lubricant	Viscosity ISO-VG DIN 51519 at 40 °C (mm ² /s)				
Mineral oils (MIN oil)	VG 460	Tribol 1100 / 460			
	VG 220	Tribol 1100 / 220			
Polyglycol (PG oil)	VG 460	Tribol 800 / 460			
	VG 220	Tribol 800 / 220			

11. Spare parts, customer-service addresses

11.1 Stocking spare parts

By stocking the most important spare and wearing parts on site you can ensure that the drive is ready for use at any time.

To order spare parts, refer to the spare-parts list.

For further information refer to the spare-parts drawing stated in the list.

We guarantee only the original spare parts supplied by us.

Caution!

Please note that spare parts and accessories not supplied by us have not been tested or approved by us. The installation and/or use of such products may therefore impair essential characteristics of the drive, thereby posing an active or passive risk to safety. FLENDER will assume no liability or guarantee for damage caused by spare parts and accessories not supplied by FLENDER.

Please note that certain components often have special production and supply specifications and that we supply you with spare parts which comply fully with the current state of technical development as well as current legislation.

When ordering spare parts, always state the following:

Order no. / Item	Type / Size	Part no.	Quantity
------------------	-------------	----------	----------

11.2 Spare-part and customer service addresses

When ordering spare parts or the services of our specialist engineers, apply first to FLENDER GMBH.

FLENDER Germany

A. FRIEDR. FLENDER GMBH

DE- 46393 Bocholt - Tel.: (0 28 71) 92-0 - Fax: (0 28 71) 92 25 96
E-mail: contact@flender.com • <http://www.flender.com>
Shipping address: Alfred - Flender - Strasse 77, DE- 46395 Bocholt

A. FRIEDR. FLENDER GMBH - Kupplungswerk Mussum

Industriepark Bocholt - Schlavenhorst 100 - DE- 46395 Bocholt - Tel.: (0 28 71) 92 28 68 - Fax: (0 28 71) 92 25 79
E-mail: anja.blits@flender.com • <http://www.flender.com>

A. FRIEDR. FLENDER GMBH - Werk Friedrichsfeld

Am Industriepark 2 - DE- 46562 Voerde - Tel.: (0 28 71) 92-0 - Fax: (0 28 71) 92 25 96
E-mail: contact@flender.com • <http://www.flender.com>

A. FRIEDR. FLENDER GMBH - Getriebewerk Penig

Thierbacher Strasse 24 - DE- 09322 Penig - Tel.: (03 73 81) 60 - Fax: (03 73 81) 8 02 86
E-mail: ute.tappert@flender.com • <http://www.flender.com>

FLENDER - TÜBINGEN GMBH

DE- 72007 Tübingen - Tel.: (0 70 71) 7 07-0 - Fax: (0 70 71) 70 74 00
E-mail: margit.holder@flender-motox.com • <http://www.flender.com>
Shipping address: Bahnhofstrasse 40, DE- 72072 Tübingen

LOHER GMBH

DE- 94095 Ruhstorf - Tel.: (0 85 31) 3 90 - Fax: (0 85 31) 3 94 37
E-mail: info@loher.de • <http://www.loher.de>
Shipping address: Hans-Loher-Strasse 32, DE- 94099 Ruhstorf

FLENDER SERVICE GMBH

DE- 44607 Herne - Tel.: (0 23 23) 940-0 - Fax: (0 23 23) 940 200
E-mail: klaus-peter.deppermann@flender-service.com • <http://www.flender-service.com>
Shipping address: Südstrasse 111, DE- 44625 Herne

A. FRIEDR. FLENDER GMBH - FLENDER GUSS

Obere Hauptstrasse 228-230, DE- 09228 Chemnitz / Wittgensdorf - Tel.: (0 37 22) 64-0 - Fax: (0 37 22) 64 21 89
E-mail: flender.guss@flender-guss.com • <http://www.flender-guss.de>

Germany

A. FRIEDR. FLENDER GMBH

DE- 46393 BOCHOLT - TEL.: (0 28 71) 92 - 0 - FAX: (0 28 71) 92 25 96

SHIPPING ADDRESS: ALFRED - FLENDER - STRASSE 77 - DE- 46395 BOCHOLT

E-mail: contact@flender.com • <http://www.flender.com>

VERTRIEBSZENTRUM HANNOVER

DE- 30839 Langenhagen
Marktplatz 3, DE- 30853 Langenhagen
Tel.: (05 11) 7 71 89 - 0
Fax: (05 11) 7 71 89 - 89
E-mail: vz.hannover@flender.com

VERTRIEBSZENTRUM HERNE

DE- 44607 Herne
Westring 303, DE- 44629 Herne
Tel.: (0 23 23) 4 97 - 0
Fax: (0 23 23) 4 97 - 2 50
E-mail: vz.herne@flender.com

VERTRIEBSZENTRUM STUTT GART

DE- 70472 Stuttgart
Friedlzheimer Strasse 3, DE- 70499 Stuttgart
Tel.: (07 11) 7 80 54 - 51
Fax: (07 11) 7 80 54 - 50
E-mail: vz.stuttgart@flender.com

VERTRIEBSZENTRUM MÜNCHEN

DE- 85750 Karlsfeld
Liebigstrasse 14, DE- 85757 Karlsfeld
Tel.: (0 81 31) 90 03 - 0
Fax: (0 81 31) 90 03 - 33
E-mail: vz.muenchen@flender.com

VERTRIEBSZENTRUM BERLIN

Schlossallee 8, DE- 13156 Berlin
Tel.: (0 30) 91 42 50 58
Fax: (0 30) 47 48 79 30
E-mail: vz.berlin@flender.com

EUROPE

AUSTRIA

Flender Ges.m.b.H.
Industriezentrum Nö-Süd
Strasse 4, Objekt 14, Postfach 132
AT - 2355 Wiener Neudorf
Phone: +43 (0) 22 36 6 45 70
Fax: +43 (0) 22 36 6 45 70 10
E-mail: office@flender.at
<http://www.flender.at>

BELGIUM & LUXEMBOURG

N.V. Flender Belge S.A.
Cyriel Buyssestraat 130
BE - 1800 Vilvoorde
Phone: +32 (0) 2 2 53 10 30
Fax: +32 (0) 2 2 53 09 66
E-mail: sales@flender.be

BULGARIA / ROMANIA

A. Friedr. Flender GmbH
Vertriebszentrum Europa-Ost
Schlossallee 8
DE - 13156 Berlin
Phone: +49 (0) 30 91 42 50 58
Fax: +49 (0) 30 47 48 79 30
E-mail: vz.berlin@flender.com

CROATIA / SLOVENIA BOSNIA-HERZEGOVINA

A. Friedr. Flender GmbH
Branch Office
c/o HUM - Naklada
HR - 10000 Zagreb
Maretičeva 11
Phone: +385 (0) 1 - 6 60 08 86
Fax: +385 (0) 1 - 6 60 08 86
E-mail: bozo.markota@zg.hinet.hr

CZECH REPUBLIC

A. Friedr. Flender GmbH
Branch Office
Hotel DUO, Teplicka 17
CZ - 19000 Praha 9
Phone: +420 (0) 2 83 88 23 00
Fax: +420 (0) 2 83 88 22 05
E-mail: flender_pumpria@hotelduo.cz

DENMARK

FLENDER AS
Sydmarken 46
DK - 2860 Søborg
Phone: +45 70 25 30 00
Fax: +45 70 25 30 01
E-mail: mail@flender.dk
<http://www.fst.dk>

ESTHONIA / LATVIA / LITHUANIA

Trellest Ltd.
Mustamae 16
EE - 10617 Tallinn / Esthonia
Phone: +372 (0) 6 68 44 00
Fax: +372 (0) 6 68 44 01
E-mail: info@trellest.ee

FINLAND

Flender Oy
Korppaanmäentie 17 CL 6
FI - 00300 Helsinki
Phone: +358 (0) 9 4 77 84 10
Fax: +358 (0) 9 4 36 14 10
E-mail: webmaster@flender.fi
<http://www.flender.fi>

FRANCE

Flender s.a.r.l.
3, rue Jean Monnet - B.P. 5
FR - 78996 Elancourt Cedex
Phone: +33 (0) 1 - 30 66 39 00
Fax: +33 (0) 1 - 30 66 35 13
E-mail: sales@flender.fr

SALES OFFICES:

Flender s.a.r.l.
36, rue Jean Broquin
FR - 69006 Lyon
Phone: +33 (0) 4 - 72 83 95 20
Fax: +33 (0) 4 - 72 83 95 39
E-mail: sales@flender.fr

Flender - Graffenstaden SA
1, rue du Vieux Moulin
FR - 67400 Illkirch-Graffenstaden
B.P. 84
FR - 67402 Illkirch - Graffenstaden
Phone: +33 (0) 3 - 88 67 60 00
Fax: +33 (0) 3 - 88 67 06 17
E-mail: flencomm@flender-graff.com

GREECE

Flender Hellas
2, Delfon Str.
GR - 11146 Athens
Phone: +30 (0) 10 2 91 72 80
Fax: +30 (0) 10 2 91 71 02
E-mail: flender@otenet.gr

Mangrinox S.A.
14, Grevenon Str.
GR - 11855 Athens
Phone: +30 (0) 10 3 42 32 01 / 02 / 03
Fax: +30 (0) 10 3 45 99 28
E-mail: mangrinox@otenet.gr

Hungary

A. Friedr. Flender GmbH
Branch Office
Bécsi Út 3-5
HU - 1023 Budapest
Phone: +36 (0) 1 3 45 07 90 / 91
Fax: +36 (0) 1 3 45 07 92
E-mail: jambor.laszlo@matavnet.hu

ITALY

Flender Cigala S.p.A.
Via Privata da Strada Provinciale, 215
IT - 20040 Caponago (MI)
Phone: +39 (0) 02 95 96 31
Fax: +39 (0) 02 95 74 21 94
E-mail: info@flendercigala.it

THE NETHERLANDS

Flender Nederland B.V.
Industrieterrein Lansinghage
Platinastraat 133
NL - 2718 ST Zoetermeer
Postbus 725
NL - 2700 AS Zoetermeer
Phone: +31 (0) 79 3 61 54 70
Fax: +31 (0) 79 3 61 54 69
E-mail: sales@flender.nl
<http://www.flender.nl>

Flender Nederland B.V.
Lage Brink 5-7
NL - 7317 BD Apeldoorn
Postbus 1073
NL - 7301 BH Apeldoorn
Phone: +31 (0) 55 5 27 50 00
Fax: +31 (0) 55 5 21 80 11
E-mail: tom.alberts@flender-group.com

Bruinhof B.V.

Boterdiep 37
NL - 3077 AW Rotterdam
Postbus 9607
NL - 3007 AP Rotterdam
Phone: +31 (0) 10 4 97 08 08
Fax: +31 (0) 10 4 82 43 50
E-mail: info@bruinhof.nl
<http://www.bruinhof.nl>

NORWAY

Elektroprosess AS
Frysjaveien 40
NO - 0884 Oslo
Postboks 165 Kjelsås
N - 0411 Oslo
Phone: +47 (0) 2 2 02 10 30
Fax: +47 (0) 2 2 02 10 50 / 51
E-mail: post@elektroprosess.no

POLAND

A. Friedr. Flender GmbH
Branch Office
Oddział Mikolów, ul. Wyzwolenia 27
PL - 43 - 190 Mikolów
Phone: +48 (0) 32 2 26 45 61
Fax: +48 (0) 32 2 26 45 62
E-mail: flender@pro.onet.pl

PORTUGAL

RF Portugal Rolamentos
e Componentes Lda.
Rua do Bairro, 155
Lugar do Outeiro
PT - 4485 - 029 Aveleda VCD
Phone: +351 (0) 22 - 9 98 32 41
Fax: +351 (0) 22 - 9 98 32 40
E-mail: info@rfportugal.com

RUSSIA

F & F GmbH
Tjuschina 4-6
RU - 191119, St. Petersburg
Phone: +7 (0) 8 12 1 64 11 26, 1 66 80 43
Fax: +7 (0) 8 12 1 64 00 54
E-mail: flendergus@mail.spbnit.ru

SLOVAKIA

A. Friedr. Flender GmbH
Branch Office
Vajanského 49, P.O. Box 286
SK - 08001 Presov
Phone: / Fax: 421 (0) 51 7 70 32 67
E-mail: micenko.flender@nextra.sk

SPAIN

Flender Ibérica S.A.
Poligono Industrial San Marcos
Calle Morse, 31 (Parcela D-15)
ES - 28906 Getafe (Madrid)
Phone: +34 (0) 91 - 6 83 61 86
Fax: +34 (0) 91 - 6 83 46 50
E-mail: f-iberica@flender.es
<http://www.flender.es>

SWEDEN

Flender Svenska AB
Ellipsvägen 11
SE - 14175 Kungens kurva, Stockholm
Phone: +46 (0) 8 4 49 56 70
Fax: +46 (0) 8 4 49 56 90
E-mail: mail@flender.se
<http://www.flender.se>

SWITZERLAND

Flender AG
Zeughausstr. 48,
CH - 5600 Lenzburg
Phone: +41 (0) 62 8 85 76 00
Fax: +41 (0) 62 8 85 76 76
E-mail: info@flender.ch
<http://www.flender.ch>

TURKEY

Flender Güc Aktarma Sistemleri
Sanayi ve Ticaret Ltd. Sti.
IMES Sanayi Sitesi
E Blok 502, Sokak No. 22
TR - 81260 Dudullu - Istanbul
Phone: +90 (0) 2 16 4 66 51 41 / 42
Fax: +90 (0) 2 16 3 64 59 13
E-mail: cuzkan@flendertr.com
<http://www.flendertr.com>

UKRAINE

A. Friedr. Flender GmbH
Branch Office
c/o DIV - Deutsche Industrie-
vertretung, Prospect Pobedy 44
UA - 252057 Kiev
Phone: +380 (0) 44 4 46 80 49 / 4 46 81 44
Fax: +380 (0) 44 2 30 29 30
E-mail: marina@div.kiev.ua

UNITED KINGDOM & EIRE

Flender Power Transmission Ltd.
Thornbury Works, Leeds Road
GB - Bradford
West Yorkshire BD3 7EB
Phone: +44 (0) 12 74 65 77 00
Fax: +44 (0) 12 74 66 98 36
E-mail: flenders@flender-power.co.uk
<http://www.flender-power.co.uk>

FLENDER

YUGOSLAVIA / ALBANIA MACEDONIA

A. Friedr. Flender GmbH
Branch Office
Zmaj Jovanova 21-a
YU - 11000 Beograd
Phone: +381 (0) 11 - 18 51 10
Fax: +381 (0) 11 - 18 18 12
E-mail: gping@eunet.yu

AFRICA

NORTH AFRICAN COUNTRIES

Please refer to Flender s.a.r.l.
3, rue Jean Monnet - B.P. 5
FR - 78996 Elancourt Cedex
Phone: +33 (0) 1 - 30 66 39 00
Fax: +33 (0) 1 - 30 66 35 13,
E-mail: sales@flender.fr

EGYPT

Sons of Farid Hassanen
81 Matbaa Ahlia Street
EG - Boulac 11221, Cairo
Phone: +20 (0) 2 5 75 15 44
Fax: +20 (0) 2 5 75 17 02
E-mail: hussein@sonfarid.com

SOUTH AFRICA

Flender Power Transmission (Pty.) Ltd.
Cnr. Furnace St & Quality Rd.,
P.O. Box 131,
ZA - Isando, 1600
Johannesburg
Phone: +27 (0) 11 5 71 20 00
Fax: +27 (0) 11 3 92 24 34
E-mail: contact@flender.co.za
<http://www.flender.co.za>

SALES OFFICES:

Flender Power Transmission (Pty.) Ltd.
Unit 3 Marconi Park,
9 Marconi Crescent, Montague Gardens
P.O. Box 28283,
ZA - Bothasig 7406
Cape Town
Phone: +27 (0) 21 5 51 50 03
Fax: +27 (0) 21 5 52 38 24
E-mail: flenderc@global.co.za

Flender Power Transmission (Pty.) Ltd.
Unit 3 Goshawk Park
Falcon Industrial Estate
P.O. Box 1608,
ZA - New Germany, 3620
Durban
Phone: +27 (0) 31 7 05 38 92
Fax: +27 (0) 13 6 92 34 52
E-mail: flenderd@global.co.za

Flender Power Transmission (Pty.) Ltd.
9 Industrial Crescent, Ext. 25,
P.O. Box 17609,
ZA - Witbank, 1035
Phone: +27 (0) 13 6 92 34 38
Fax: +27 (0) 13 6 92 34 52
E-mail: gert.els@flender.co.za

Flender Power Transmission (Pty.) Ltd.
Unit 14 King Fisher Park, Alton
Cnr. Ceramic Curve & Alumina Allee
P.O. Box 101995,
ZA - Meerensee, 3901
Richards Bay
Phone: +27 (0) 3 51 7 51 15 63
Fax: +27 (0) 3 51 7 51 15 64
E-mail: flenderr@global.co.za

AMERICA

BRASIL

Flender Brasil Ltda.
Rua Quadorze, 60 - Cidade Industrial
Caixa Postal 296
32.211-970,
BR - Contagem - MG
Phone: +55 (0) 31 33 69 20 00
Fax: +55 (0) 31 33 69 21 66

SALES OFFICES:

Flender Brasil Ltda.
Rua Cruzeiro, 549 - Barra Funda
01.137-000,
BR - São Paulo - SP
Phone: +55 (0) 11 36 12 30 30
Fax: +55 (0) 11 36 12 34 32
E-mail: flesao@uol.com.br

Flender Brasil Ltda.
Rua São José, 1010, S/22 - Centro
14.010-160,
BR - Ribeirão Preto - SP
Phone: +55 (0) 16 6 35 15 90
Fax: +55 (0) 16 6 35 11 05
E-mail: flender.ribpreto@uol.com.br

CANADA

Flender Power Transmission Inc.
215 Shields Court, Units 4 - 6
CA - Markham,
Ontario L3R 8V2
Phone: +1 (0) 9 05 3 05 10 21
Fax: +1 (0) 9 05 3 05 10 23
E-mail: flender@interlog.com
<http://www.flenderpti.com>

SALES OFFICES:

Flender Power Transmission Inc.
34992 Bemina Court
CA - Abbotsford-Vancouver,
B.C. V3G 1C2
Phone: +1 (0) 6 04 8 59 66 75
Fax: +1 (0) 6 04 8 59 68 78
E-mail: tvickers@rapidnet.net

CHILE / ARGENTINA / BOLIVIA ECUADOR / PARAGUAY / URUGUAY

Flender Cono Sur Ltda.
Avda. Galvarino Gallardo # 1534
Providencia,
CL - Santiago
Phone: +56 (0) 2 2 35 32 49
Fax: +56 (0) 2 2 64 20 25
E-mail: flender@flender.cl
<http://www.flender.cl>

COLOMBIA

A.G.P. Representaciones Ltda.
Flender Liaison Office Colombia
Calle 53 B, No. 24 - 80 Of. 501
Apartado 77158,
CO - Bogotá
Phone: +57 (0) 1 3 46 05 61
Fax: +57 (0) 1 3 46 04 15
E-mail: agprepre@colomsat.net.co

MEXICO

Flender de Mexico, S.A. de C.V.
Vista Hermosa No. 23
Col. Romero Vargas
Apdo. Postal 2 - 85, C.P. 72121
MX - Puebla, Puebla
Phone: +52 (0) 222 2 31 09 51
Fax: +52 (0) 222 2 31 09 13
E-mail: szugasti@flendermexico.com
<http://www.flendermexico.com>

SALES OFFICES:

Flender de Mexico, S.A. de C.V.
Lago Nargis No. 38,
Col. Granada, C.P. 11520,
MX - Mexico, D.F.
Phone: +52 (0) 55 52 54 30 37
Fax: +52 (0) 55 55 31 69 39
E-mail: info@flendermexico.com

Flender de Mexico, S.A. de C.V.
Rio Necaxa 1207,
Col. Valle Oriente, C.P. 66220
MX - Garza Garcia, N.L.
Phone: +52 (0) 81 83 63 82 82
Fax: +52 (0) 81 83 63 82 83
E-mail: info@flendermexico.com

PERU

Potencia Industrial E.I.R.L.
Calle Victor González Olaechea N° 110
Urb. La Aurora - Miraflores,
P.O.Box: Av. 2 de Mayo N° 679
Of.108-Miraflores
Casilla N° 392,
PE - Lima 18
Phone: +51 (0) 1 2 42 84 68
Fax: +51 (0) 1 2 42 08 62
E-mail: cesarzam@chavin.rcp.net.pe

USA

Flender Corporation
950 Tollgate Road, P.O. Box 1449
US - Elgin, IL. 60123
Phone: +1 (0) 8 47 9 31 19 90
Fax: +1 (0) 8 47 9 31 07 11
E-mail: dweilandt@flenderusa.com
<http://www.flenderusa.com>

Flender Corporation
Service Centers West
4234 Foster Ave.,
US - Bakersfield, CA. 93308
Phone: +1 (0) 6 61 3 25 44 78
Fax: +1 (0) 6 61 3 25 44 70
E-mail: flender1@lightspeed.net
E-mail: flender2@lightspeed.net

VENEZUELA

F. H. Transmisiones S.A.
Urbanización Buena Vista
Calle Johan Schafer o Segunda Calle
Municipio Sucre, Petare
VE - Caracas
Phone: +58 (0) 2 21 52 61
Fax: +58 (0) 2 21 18 38
E-mail: fhtransm@telcel.net.ve
<http://www.fhtransmisiones.com>

ASIA

SINGAPORE

Flender Singapore (Pte.) Ltd.
13A, Tech Park Crescent
SG - Singapore 637843
Phone: +65 98 97 94 66
Fax: +65 98 97 94 11
E-mail: flensi@singnet.com.sg
<http://www.flender.com.sg>

BANGLADESH / SRI LANKA

Please refer to Flender Limited
No. 2 St. George's Gate Road
5th Floor, Hastings,
IN - Kolkata - 700 022
Phone: +91 (0) 33 2 23 05 45
2 23 08 46, 2 23 52 85
Fax: +91 (0) 33 2 23 18 57
E-mail: flender@flenderindia.com

PEOPLE'S REPUBLIC OF CHINA

Flender Power Transmission
(Tianjin) Co. Ltd.
ShuangHu Rd.- Shuangchen Rd. West
Beichen Economic Development
Area (BEDA)
CN - Tianjin - 300400,
Phone: +86 (0) 22 26 97 20 63
Fax: +86 (0) 22 26 97 20 61
E-mail: flender@flendertj.com
<http://www.flendertj.com>

Flender Chief Representative Office
C-415, Lufthansa Center
50 Liangmaqiao Road, Chaoyang District
CN - Beijing - 100016,
Phone: +86 (0) 10 64 62 21 51
Fax: +86 (0) 10 64 62 21 43
E-mail: beijing@flenderprc.com.cn

Flender Shanghai
Representative Office
Unit 1101 - 1102
Harbour Ring Plaza
No. 18 Xizang Zhong Road
CN - Shanghai - 200 001,
Phone: +86 (0) 21 53 85 31 47
Fax: +86 (0) 21 53 85 31 46
E-mail: shanghai@flenderprc.com.cn

Flender Guangzhou Representative Office
Room 952, Business Tower, China Hotel
Lihua Road
CN - Guangzhou 510015,
Phone: +86 (0) 20 86 66 13 23
Fax: +86 (0) 20 86 66 28 60
E-mail: guangzhou@flenderprc.com.cn

Flender Chengdu Representative Office
Unit G, 6/F, Sichuan Guoxin
Mansion 77 Xiyu Street
CN - Chengdu 610015,
Phone: +86 (0) 28 86 19 83 72
Fax: +86 (0) 28 86 19 88 10
E-mail: chengdu@flenderprc.com.cn

FLENDER

Flender Wuhan Representative Office
Room 1104, Business Tower, Wuhan Plaza
688 Jiefang Road, Wuhan-hankou
CN - Wuhan 430022,
Phone: +86 (0) 27 85 48 67 15
Fax: +86 (0) 27 85 48 68 36
E-mail: wuhan@flenderprc.com.cn

INDIA

Flender Limited
Head Office:
No. 2 St. George's Gate Road,
5th Floor, Hastings,
IN - Kolkata - 700 022
Phone: +91 (0) 33 2 23 05 45, 2 23 08 46
Fax: +91 (0) 33 2 23 08 30
E-mail: flender@flenderindia.com

Flender Limited
Industrial Growth Center
Rakhajungle, Nimpura,
IN - Kharagpur - 721 302
Phone: +91 (0) 32 22 73 33 07, 22 73 33 08
Fax: +91 (0) 32 22 73 33 64
E-mail: works@flenderindia.com

SALES OFFICES:

Flender Limited
Eastern Regional Office
No. 2 St. George's Gate Road,
5th Floor, Hastings,
IN - Kolkata - 700 022
Phone: +91 (0) 33 2 23 05 45, 2 23 08 46
Fax: +91 (0) 33 2 23 08 30
E-mail: ero@flenderindia.com

Flender Limited
Western Regional Office
Plot. No. 23, Sector 19-A, Vashi
IN - Navi Mumbai - 400 705,
Phone: +91 (0) 22 7 65 72 27, 7 66 95 98
Fax: +91 (0) 22 7 65 72 28
E-mail: wro@flenderindia.com

Flender Limited
Southern Regional Office
41 Nelson Manickam Road
Aminjikarai,
IN - Chennai - 600 029
Phone: +91 (0) 44 3 74 39 21, 3 74 39 22
Fax: +91 (0) 44 3 74 39 19
E-mail: sro@flenderindia.com

Flender Limited
Northern Regional Office
209 - A, Masjid Moth, 2nd Floor
(Behind South Extension II)
IN - New Delhi
Phone: +91 (0) 11 6 25 02 21, 6 25 01 04
Fax: +91 (0) 11 6 25 63 72
E-mail: nro@flenderindia.com

INDONESIA

Flender Jakarta
Representative Office
Perkantoran Puri Niaga II
Jalan Puri Kencana Blok J1 No. 21
Kembangan,
ID - Jakarta Barat 11610
Phone: +62 (0) 21 5 82 86 24
Fax: +62 (0) 21 5 82 86 23
E-mail: bobwall@pacific.net.id

PT Flenindo Aditransimisi
Jl. Ketintang Wiyata VI No. 22
ID - Surabaya 60231
Phone: +62 (0) 31 8 29 10 82
Fax: +62 (0) 31 8 28 63 63
E-mail: gnsbyfld@indo.net.id

IRAN

Cimaghand Co. Ltd.
P.O. Box 15745-493,
No. 13, 16th East Street
Beyhaghi Ave., Argentina Sq.,
IR - Tehran 15156
Phone: +98 (0) 21 8 73 02 14, 8 73 02 59
Fax: +98 (0) 21 8 73 39 70
E-mail: cmgdir@dpi.com

ISRAEL

Greenshpon Engineering
Works Ltd.
Haamelim Street 20
P.O. Box 10108,
IL - 26110 Haifa
Phone: +972 (0) 4 8 72 11 87
Fax: +972 (0) 4 8 72 62 31
E-mail: sales@greenshpon.com
http://www.greenshpon.com

JAPAN

Ishibashi Manufacturing Co. Ltd.
4636 - 15, Oaza Kamitonno
Noogata City,
JP - Fukuoka, (Zip 822-0003)
Phone: +81 (0) 94 92 6 37 11
Fax: +81 (0) 94 92 6 39 02
E-mail: sales@ishibashi-mfg.com

KOREA

Flender Ltd.
7th Fl. Dorim Bldg.
1823 Bangbae-Dong, Seocho-Ku,
KR - Seoul 137-060
Phone: +82 (0) 2 34 78 63 37
Fax: +82 (0) 2 34 78 63 45
E-mail: flender@nuri.net

KUWAIT

South Gulf Company
Al-Reqai, Plot 1, Block 96
P.O. Box 26229
KW - Safat 13123
Phone: +965 (0) - 4 88 39 15
Fax: +965 (0) - 4 88 39 14
E-mail: adelameen@hotmail.com

LEBANON

Gabriel Acar & Fils s.a.r.l.
Dahr-el-Jamal, Zone Industrielle
Sin-el-Fil, B.P. 80484,
LB - Beyrouth
Phone: +961 (0) 1 49 47 86
Fax: +961 (0) 1 49 49 71
E-mail: gacar@beirut.com

MALAYSIA

Flender Singapore Pte. Ltd.
Sales Office:
37 A - 2, Jalan PJU 1/39
Dataran Prima
MY - 47301 Petaling Jaya
Selangor Darul Ehsan
Phone: +60 (0) 3 - 78 80 42 63
Fax: +60 (0) 3 - 78 80 42 73
E-mail: flender@tm.net.my

PAKISTAN

Please refer to
A. Friedr. Flender GmbH
DE - 46393 Bocholt
Phone: +49 (0) 28 71 - 92 22 59
Fax: +49 (0) 28 71 - 92 15 16
E-mail: ludger.wittag@flender.com

PHILIPPINES

Otec Philippines, Inc.
Rm 209-210 Quinio Building
#64 Sen. Gil J. Puyat Avenue
PH - Makati City,
Phone: +63 (0) 2 8 44 82 18, 8 92 46 36
Fax: +63 (0) 2 8 43 72 44
E-mail: litoq@otec-pemex.com

BAHRAIN / IRAQ / JORDAN / LYBIA

OMAN / QATAR / U.A.E. / YEMEN
Please refer to A. Friedr. Flender GmbH
Middle East Sales Office
IMES Sanayi Sitesi
E Blok 502, Sokak No. 22
TR - 81260 Dudullu-Istanbul
Phone: +90 (0) 2 16 4 99 66 23 / 4 99 66 24
Fax: +90 (0) 2 16 3 64 59 13
E-mail: meso@flendertr.com

SAUDI ARABIA

South Gulf Sands est.
Al-Thoqba, Kharaj Road Cross 1
P.O. Box 20434
SA - Al-Khobar
Phone: +966 (0) 3 - 8 93 76 33
Fax: +966 (0) 3 - 8 93 76 47
E-mail: adelameen@hotmail.com

SINGAPORE

Flender Singapore Pte. Ltd.
13 A, Tech Park Crescent
SG - Singapore 637843
Phone: +65 (0) - 68 97 94 66
Fax: +65 (0) - 68 97 94 11
E-mail: flender@singnet.com.sg
http://www.flender.com.sg

SYRIA

Misrabi Co & Trading
Mezzeh AutoTrade Transportation
Building 4/A, 5th Floor
P.O. Box 12450
SY - Damascus
Phone: +963 (0) 11 - 6 11 67 94
Fax: +963 (0) 11 - 6 11 09 08
E-mail: ismael.misrabi@gmx.net

TAIWAN

A. Friedr. Flender GmbH
Taiwan Branch Office
1F, No. 5, Lane 240
Nan Yang Street, Hsichih
TW - Taipei Hsien
Phone: +886 (0) 2 26 93 24 41
Fax: +886 (0) 2 26 94 36 11
E-mail: flentwan@seed.net.tw

THAILAND

Flender Representative Office
23/F M Thai Tower, All Seasons Place
87 Wireless Road, Phatumwan
TH - Bangkok 10330
Phone: +66 (0) 2 - 6 27 91 09
Fax: +66 (0) 2 - 6 27 90 01
E-mail: christian.beckers@flender.th.com

VIETNAM

Flender Representative Office
Suite 6/6A, 16F Saigon Tower
29 Le Duan Street, District 1
Ho Chi Minh City
VN - Vietnam
Phone: +84 (0) 8 - 8 23 62 97
Fax: +84 (0) 8 - 8 23 62 88
E-mail: flender@hcm.vnn.vn

A U S T R A L I A

Flender (Australia) Pty. Ltd.
9 Nello Place, P.O. Box 6047
Whetherill Park, N.S.W. 2164
AU - Sydney
Phone: +61 (0) 2 97 56 23 22
Fax: +61 (0) 2 97 56 48 92, 97 56 14 92
E-mail: stevew@flender.com.au
http://www.flender.com.au

SALES OFFICES:
Flender (Australia) Pty. Ltd.
Suite 3, 261 Centre Rd.
AU - Bentleigh, VIC, 3204 Melbourne
Phone: +61 (0) 3 - 95 57 08 11
Fax: +61 (0) 3 - 95 57 08 22
E-mail: ernie@flender.com.au

Flender (Australia) Pty. Ltd.
Suite 5 - 1407 Logan Rd.
Mt. Gravatt
AU - QLD 4122 Brisbane
Phone: +61 (0) 7 34 22 23 89
Fax: +61 (0) 7 34 22 24 03
E-mail: johnw@flender.com.au

Flender (Australia) Pty. Ltd.
Suite 2 403 Great Eastern Highway
AU - W.A. 6104, Redcliffe, Perth
Phone: +61 (0) 8 94 77 41 66
Fax: +61 (0) 8 94 77 65 11
E-mail: paulj@flender.com.au

NEW ZEALAND

Please refer to Flender (Australia) Pty. Ltd.
9 Nello Place, P.O. Box 6047
Whetherill Park,
AU - N.S.W. 2164, Sydney
Phone: +61 (0) 2 97 56 23 22
Fax: +61 (0) 2 97 56 48 92 / 97 56 14 92
E-mail: stevew@flender.com.au

12. Declaration by the manufacturer

Declaration by the manufacturer

in accordance with EEC Engineering Guideline 98/37/EG, Appendix I I B

We hereby declare that the

Lift Drive Type
CG 45
Size 120

described in these Operating Instructions are intended for incorporation in a machine, and that it is prohibited to put them into service before verifying that the machine into which they are incorporated complies with the EEC Guidelines (original edition 98/37/EG including any subsequent amendments thereto).

This Manufacturer's Declaration takes into account all the unified standards (inasmuch as they apply to our products) published by the European Commission in the Official Journal of the European Community.



Bocholt, 2002-10-16

Signature (person responsible for products)

ZERTIFIKAT ◆ CERTIFICATE ◆ CERTIFICADO ◆ CERTIFICAT ◆ 認 証 証 書 ◆ ΕΠΙΤΡΑΧΗ

EC type-examination certificate



Certificate no.: ABV 603
Notified body: TÜV Süddeutschland Bau und Betrieb GmbH
 Zertifizierungsstelle
 für Aufzüge und Sicherheitsbauteile
 Westendstraße 199, D-80686 München
**Applicant/
 Certificate holder:** WARNER & TOURCO
 Route de Spay,
 B.P. 17
 F-72700 Allonnes
Date of submission: 2001-10-29
Manufacturer: WARNER & TOURCO
 7 rue Champfleür
 B.P. 95
 F-49182 St. Barthelemy D'Anjou
Product, type: Braking device acting on the shaft of the traction sheave, as
 part of the protection device against overspeed for the car
 moving in upwards direction, type ERS VAR 08 SZ 800/___
Test Laboratory: TÜV Süddeutschland Bau und Betrieb GmbH
 Abteilung Aufzüge und Sicherheitsbauteile
 Westendstraße 199, D-80686 München
**Date and
 Number of test report:** 2001-11-07
 603
EC-directive: 95 / 16 / EC
Statement: The safety component conforms to the directive's essential
 safety requirements for the respective scope of application
 stated on page 1 - 2 of the annex to this EC type-examination
 certificate.
Certificate date: 2001-11-07

Zertifizierungsstelle für Aufzüge und Sicherheitsbauteile
 Identification number: 0036

P. Tkalec
 Peter Tkalec

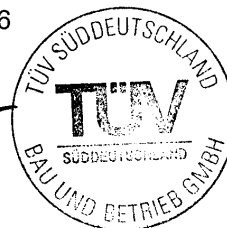



Annex to the EC type-examination certificate No. ABV 603 dated 2001-11-07

1. Scope of Application

1.1 Permissible brake moment when the braking device acts on the shaft of the traction sheave while the car is moving upward 391 - 828 Nm

1.2 Maximum tripping speed of the overspeed governor and maximum rated speed

The maximum tripping speed and the maximum rated speed must be calculated on the basis of the traction sheave's maximum tripping rotary speed and maximum rated rotary speed as outlined in sections 1.2.1 and 1.2.2 taking into account traction sheave diameter and car suspension.

$$v = \frac{D \times \pi \times n}{60 \times i}$$

v = speed (m/s)
 D = Diameter of the traction sheave from rope's center to rope's center (m)
 π = 3,14
 n = Rotary speed (min⁻¹)
 i = Ratio of the car suspension

1.2.1 Maximum tripping rotary speed of the traction sheave 250 min⁻¹

1.2.2 Maximum rated rotary speed of the traction sheave 217 min⁻¹

2. Conditions

2.1 Since the braking device represents only a part of the protection device against overspeed for the car moving in upwards direction an overspeed governor as per EN 81-1, paragraph 9.9 must be used to monitor the upward speed and the braking device must be triggered (engaged) via the overspeed governor's electric safety device.

Alternatively, the speed may also be monitored and the braking device engaged by a device other than an overspeed governor as per paragraph 9.9 if the device shows the same safety characteristics and has been type tested.

If the overspeed governor's electrical safety device is actuated in the same way, irrespective of whether the car is travelling upwards or downwards (consequence: braking device also responds when the car is travelling downwards) and the lift travels with a rated speed of more than 1 m/s, the electrical safety device must respond at speed clearly below (approx. 10 %) the speed at which the overspeed governor is triggered (for the safety gear).

If the braking device is triggered via an additional (second) electrical safety device of the overspeed governor, this device only has to be activated when the triggering speed of the overspeed governor is reached.

2.2 The energy supply to the magnetic coin must be directly interrupted by the overspeed governor's electrical safety device or two independently actuated operational elements being dependent on this safety device. In case no speed governor is installed (cf.2.1) interruption has to be made analogue.

- 2.3 When the braking device responds (anchors in braking position) an electrical device must be actuated (e.g. micro switches). (The actuation of the overspeed governor's electrical safety device satisfies the requirement outlined in Section 9.10.5, i. e. that an electrical safety device in conformity with 14.1.2 must be operated upon response of the protection device).
- 2.4 The triggering of the braking device (release of the anchor plates for engagement by means of pressure springs) is not caused positive mechanically but electrically resp. electromagnetically by interruption of the energy supply to the magnetic coil of the braking device (see point 2.2). However, the mechanical engagement of the braking device has to be absolutely guaranteed after the electrical safety device has responded.

In light of the above, the braking device must be made to engage at regular intervals, so that the anchor plates can be checked for correct closing. This may be done, for example, by engaging the braking device after every stop, in which case the braking device adopts an additional safety function, or once daily through (automatic) operation of the braking device when the lift is at standstill. If the anchor plates do not perform correctly (anchors fail to close) the lift must be kept at standstill.

- 2.5 Appropriate measures must ensure that it is evident in the machine room whether the braking device has responded in line with its intended use as a safety component (following failure of an item of operating equipment such as breakage of a gearing element or shaft) or whether the response was caused by other reasons (e. g. loss of power supply or reaction after every stop or as required under Section 2.4). It must also be evident how to proceed in emergency operation (moving the car through manual operation or return motion control) after the braking device has responded.

Once the braking device has responded in the intended way as a safety component, it should never be possible to move the lift machine via the return motion control.

- 2.6 The braking device must act on the shaft of the traction sheave in the immediate vicinity of the traction sheave. The manufacturer of the drive unit must provide calculation evidence that the connection braking device - shaft and traction sheave - shaft is sufficiently safe. The calculation evidence must be enclosed with the technical documentation of the lift.

3. Remarks

- 3.1 The brake moment effectively adjusted will be marked at the blank after the type designation ERS VAR 08 SZ 800/___ within the permissible scope of application of 391 - 828 Nm.
- 3.2 The permissible braking moments must be applied to the lift system in such a manner that they do not decelerate more than 1_{gn} , if the empty car is moving upwards.
- 3.3 In order to provide identification and information about the design and its functioning drawing No. 1 12 106603, dated 29 October 2001 is to be enclosed with the EC type-examination certificate and the Annex thereto. The installation conditions and connection requirements are presented or described in separate documents (e.g. operating instructions).
- 3.4 The EC type-examination certificate may only be used in connection with the pertinent Annex.

