

Operating Instructions

BA 9202 EN 10.07

Combined Gear Unit

Radial piston motor with planetary gear unit types

PEA, PEB, PEF Sizes 112 to 335

PZA, PZB, PZF Sizes 170 to 375

PEA
PZA

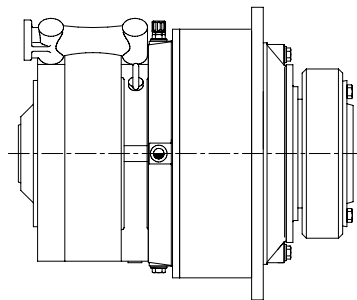

PEB
PZB

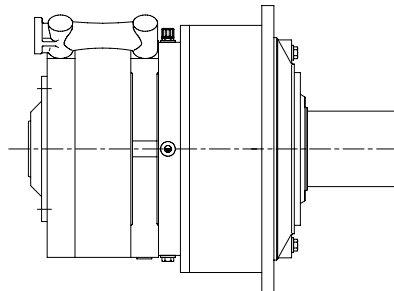

PEF
PZF

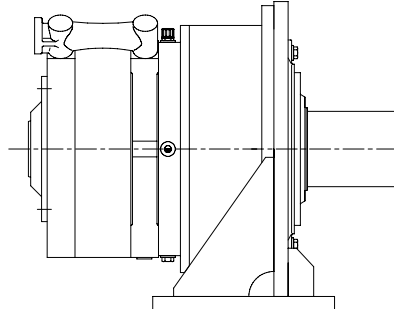

FLENDER

Contents

1.	Technical data	4
1.1	General technical data	4
1.2	Weights	5
1.3	Measuring-surface sound-pressure level	5
2.	General notes	6
2.1	Introduction	6
2.2	Copyright	6
3.	Safety instructions	7
3.1	Proper use	7
3.2	Obligations of the user	7
3.3	Environmental protection	8
3.4	Special dangers	8
3.5	Warnings and symbols used in these Operating Instructions	8
4.	Handling and storage	8
4.1	Scope of supply	8
4.2	Handling	9
4.3	Storing the gear unit	10
4.4	Standard corrosion protection	10
5.	Technical description	11
5.1	General description	11
5.2	Housing	11
5.3	Toothed components	12
5.4	Lubrication	12
5.5	Shaft bearings	12
5.6	Shaft seals, static seals	12
5.7	Couplings	12
5.8	Shrink disk	12
5.9	Backstop	13
6.	Fitting	13
6.1	General information on fitting	13
6.2	Foundation	14
6.3	Description of installation work	14
6.4	Shrink disk	15
6.4.1	Fitting the shrink disk	15
6.4.2	Demounting and remounting the shrink disk	16
6.4.2.1	Cleaning and greasing the shrink disk	16
6.5	Installation of the torque arm	17
6.5.1	One-sided torque arm	17
6.5.2	Double-sided torque arm	17
6.6	Final work	18

7.	Start-up	18
7.1	Procedure before start-up	18
7.1.1	Removal of preservative agent	18
7.2	Filling with lubricant	19
7.3	Start-up	19
7.4	Gear unit with backstop	20
7.5	Removal from service	20
7.5.1	Interior preservation during longer disuse	20
7.5.1.1	Interior preservation with gear oil	20
7.5.1.2	Interior preservation with preservative agent	20
7.5.2	Exterior preservation	21
8.	Operation	22
9.	Faults, causes and remedy	22
9.1	General information on faults and malfunctions	22
9.2	Possible faults	23
10.	Maintenance and repair	24
10.1	General notes on maintenance	24
10.2	Description of maintenance and repair work	25
10.2.1	Testing water content of oil	25
10.2.2	Changing the oil	26
10.2.3	Cleaning the breather screw	26
10.2.4	Refilling Taconite seals with grease	26
10.2.5	Cleaning the gear unit	26
10.2.6	Check oil cooling system	27
10.2.7	Topping up oil	27
10.2.8	Checking tightness of fastening bolts	27
10.3	Final work	27
10.3.1	General inspection of gear unit	28
10.4	Lubricants	28
11.	Spare parts, customer-service addresses	28
11.1	Stocking spare parts	28
11.2	Spare parts and customer-service addresses	28
12.	Declaration by the manufacturer	34

1. Technical data

1.1 General technical data

The most important technical data are shown on the rating plate. For further data please refer to the drawings, these Operating Instructions and a Technical Data Sheet, if any.

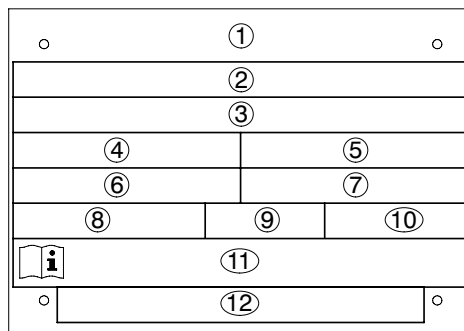

- | | |
|---|--|
| ① Company logo and place of manufacture | ⑦ Speed n_2 |
| ② Special information | ⑧ Type of oil |
| ③ Order no. - item - seq. no. | ⑨ Viscosity of oil in VG class |
| ④ Type / Size *) | ⑩ Quantity of oil in litres for main housing |
| ⑤ Power rating P in kW or T_2 in Nm | ⑪ Operating instructions number(s) |
| ⑥ Speed n_1 | ⑫ Special information |

*) Example

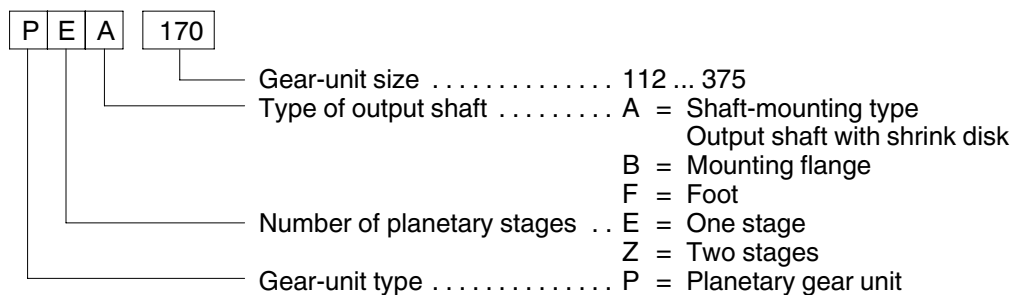

1.2 Weights

Type	Approx. weight (kg) for combined gear unit (gear-unit size/motor size)																								
	112		125		140		150		170		200		224		250		265		280		300		335		
	HMS		HMS		HMS		HMS		HMS		HMS		HMS		HMS		HMS		HMS		HMS		HMS		
	345	410	410	455	455	515	515	575	575	635	635	690	690	745	745	745	910.1	910	910	910	910	910	910	910	
PEA	455	565	650	720	750	855	980	1110	1300	1460	1920	2090	2300	2500	2800	4100	4800	6200	7500						
PEB	355	470	520	590	750	855	920	1050	1220	1380	1810	1980	2200	2400	2600	3700	4300	5500	6800						
PEF	415	530	595	665	830	935	1020	1150	1350	1510	1990	2160	2420	2620	2880	4100	4800	6100	7500						

Table 1.1: Weights for type PE.

Type	Approx. weight (kg) for combined gear unit (gear-unit size/motor size)																								
	170		200		250		265		300		315		355			375									
	HMS		HMS		HMS		HMS		HMS		HMS		HMS			HMS									
	345	345	410	410	455	455	515	515	575	575	635	635	575	635	690	635	690	745							
PZA	1100	1660	1725	2785	2840	3370	3460	5010	5130	5950	6100	7530	7680	7850	8980	9150	9320								
PZB	1020	1550	1620	2610	2670	3170	3260	4710	4830	5630	5780	7230	7380	7550	8580	8750	8920								
PZF	1150	1730	1795	2895	2950	3500	3590	5160	5280	6230	6380	8130	8280	8450	9680	9850	10020								

Table 1.2: Weights for type PZ.

Note: All weights are for units without oil filling or add-on parts. For the exact weights, refer to the drawings in the gear-unit documentation.

1.3 Measuring-surface sound-pressure level

The gear unit has a measuring-surface sound-pressure level at a distance of 1 m which will be found on the rating plate.

The measurement is carried out to DIN 45 635 Parts 1 and 23, using the sound-intensity method.

The workplace of the operating personnel is defined as the area on the measuring-surface at a distance of 1 metre in the vicinity of which persons may be present.

The sound-pressure level applies to the warmed up gear unit at input speed n_1 and input power P_1 stated on the rating plate. If several figures are given, the highest speed and power values apply.

The measuring-surface sound-pressure level includes add-on lubrication units (if applicable). With outgoing and incoming pipes, the interfaces are the flanges.

If repeat measurements on site do not produce conclusive results with regard to measuring technology, the measurement obtained on the FLENDER test bench will apply.

The given sound-pressure level was determined by statistical evaluations of our quality control department. In accordance with the confidence coefficient, it can be expected that the gear unit noise will be within the given value.

2. General notes

2.1 Introduction

These Operating Instructions (BA) are an integral part of the gear unit supplied and must be kept in its vicinity for reference at all times.

Note: This includes the operating instructions for the add-on hydraulic motor.

Caution!

All persons involved in the installation, operation, maintenance and repair of the gear unit must have read and understood these Operating Instructions (BA) and must comply with them. We accept no responsibility for damage or disruption caused by disregard of these Instructions.

The "**FLENDER planetary gear unit**" described in these Instructions has been developed for stationary use in general engineering applications. Possible areas of use for gear units of this type are (e.g.) sewage treatment, excavators, chemical industry, iron and steel industry, conveyor systems, crane systems, foodstuffs industry, paper machinery, cableways, cement industry, etc.

The gear unit is designed only for the application described in section 1, "Technical data".

The gear unit described in these Operating Instructions reflects the state of technical development at the time these Instructions went to print.

In the interest of technical progress we reserve the right to make changes to the individual assemblies and accessories which we regard as necessary to preserve their essential characteristics and improve their efficiency and safety.

2.2 Copyright

The copyright to these Operating Instructions is held by **FLENDER AG**.

These Operating Instructions (BA) must not be wholly or partly reproduced for competitive purposes, used in any unauthorised way or made available to third parties without our agreement.

Technical enquiries should be addressed to the following works

A. FRIEDR. FLENDER AG
Geschäftsbereich Heavy Duty
Am Industriepark 2
D - 46562 Voerde / Friedrichsfeld

Tel.: 02871/92-0
Fax: 02871/92-1544
E-Mail: heavy.duty@flender.com

Internet: www.flender.com

or to one of our customer-service addresses. A list of our customer-service addresses is given in section 11, "Spare parts, customer-service addresses".

3. Safety instructions

Note: For the safety notes for the attached hydraulic motor, see the operating instructions for this motor.

3.1 Proper use

- The gear unit has been manufactured in accordance with the state of the art and is delivered in a condition for safe and reliable use. Any changes on the part of the user which may affect safety and reliability are prohibited. This applies equally to safety features designed to prevent accidental contact.
- The gear unit should be used and operated only within the context of the conditions laid down in the contract governing performance and supply.

3.2 Obligations of the user

- The operator must ensure that all persons involved in installation, operation, maintenance and repair have read and understood these Operating Instructions (BA) and comply with them at all times in order to:
 - avoid injury or damage,
 - ensure the safety and reliability of the unit,and
 - avoid disruptions and environmental damage through incorrect use.
- During transport, assembly, installation, dismantling, operation and maintenance of the unit, the relevant safety and environmental regulations must be complied with at all times.
- The gear unit should be operated, maintained or repaired by authorised, trained and qualified personnel.
- The gear unit must not be cleaned using high-pressure cleaning equipment.
- All work must be carried out with great care and with due regard to safety.
- All work on the gear unit must be carried out only when it is not in operation. The drive unit must be secured against being switched on accidentally (e.g. by locking the key switch or removing the fuses from the power supply). A notice should be attached to the start switch stating clearly that work is in progress.
- No welding work must be done on the gear unit. The gear unit must not be used as an earthing point for welding operations. Toothed parts and bearings may be irreparably damaged by welding.
- If any changes are noticed during operation (e.g. overheating or unusual noises), the drive assembly must be switched off immediately.
- Rotating drive components such as couplings, gearwheels, belt drives etc. must be protected against accidental contact.
- If the gear unit is intended for installation in plant or machinery, the manufacturer of such plant or machinery must ensure that the contents of these Instructions are incorporated in his own instructions.
- Notices attached to the gear unit, e.g. rating plate, direction arrows etc. must always be observed. They must be kept free from dirt and paint at all times. Missing plates must be replaced.
- Screws which have been damaged during assembly or disassembly work must be replaced with new ones of the same strength class and type.
- Spare parts should always be obtained from FLENDER (see also section 11).

3.3 Environmental protection

- When changing oil, the used oil must be collected in suitable containers. Any spillage of oil must be removed immediately.
- Preservative agent should be stored separately from used oil.
- Used oil, preservative agent, oil-binding agents and oil-soaked cloths must be disposed of in accordance with environmental legislation.

3.4 Special dangers

- Depending on operating conditions, the surface of the gear unit may heat up considerably.
Danger of burns!
- When changing oil, take care to prevent scalding by hot oil.
- Small foreign matter such as sand, dust, etc. can get into the cover plates of the rotating parts and be thrown back by these. Eye protection must therefore be worn while the gear unit is operating.

3.5 Warnings and symbols used in these Operating Instructions



This symbol indicates safety measures which must be observed to avoid **personal injury**.

Caution!

This symbol indicates safety measures which must be observed to avoid **damage to the gear unit**.

Note: This symbol indicates general **operating instructions** which are of particular importance.

4. Handling and storage

Observe the "Safety instructions" in section 3!

Note: For transport and storage of the add-on hydraulic motor, please refer to operating instructions for this motor.

4.1 Scope of supply

The products supplied are listed in the despatch papers. Check immediately on receipt to ensure that all the products listed have actually been delivered. Parts damaged during transport or missing parts must be reported in writing immediately to FLENDER AG.

Caution!

If damage has occurred, the gear unit must not be put into operation.

The gear unit is delivered in the fully assembled condition. Additional items (e.g. oil cooler, pipes and fittings) can be delivered separately packaged.

If the unit is fitted with a shrink disk, this will be shipped as a loose component.

4.2 Handling



**When handling FLENDER products, use only lifting and handling equipment of sufficient load-bearing capacity!
Wedges or rails must be used to prevent rolling.**

Different forms of packaging may be used, depending on the size of the unit and method of transport. Unless otherwise agreed, the packaging complies with the **HPE Packaging Guidelines**.

The symbols marked on the packaging must be observed at all times. These have the following meanings:

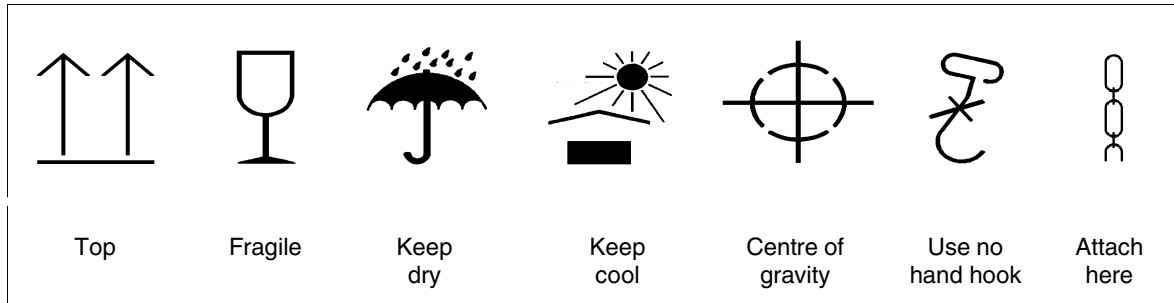

Caution!

The combined gear unit must always be transported with great care in order to avoid injury to persons or damage to the gear unit and hydraulic motor. If, for example, the free shaft ends are knocked, this may damage the gear unit.

Note:

The combined gear unit must be transported with suitable equipment only. Never transport the combined gear unit with an oil charge.

Caution!

The combined gear unit may be handled only by using the existing brackets, eye bolts or lifting eyes. Do not use the front threads at the shaft ends to attach eye bolts for transport.

Caution!

If fitted with a shrink disk, the shrink disk must be secured axially before handling.

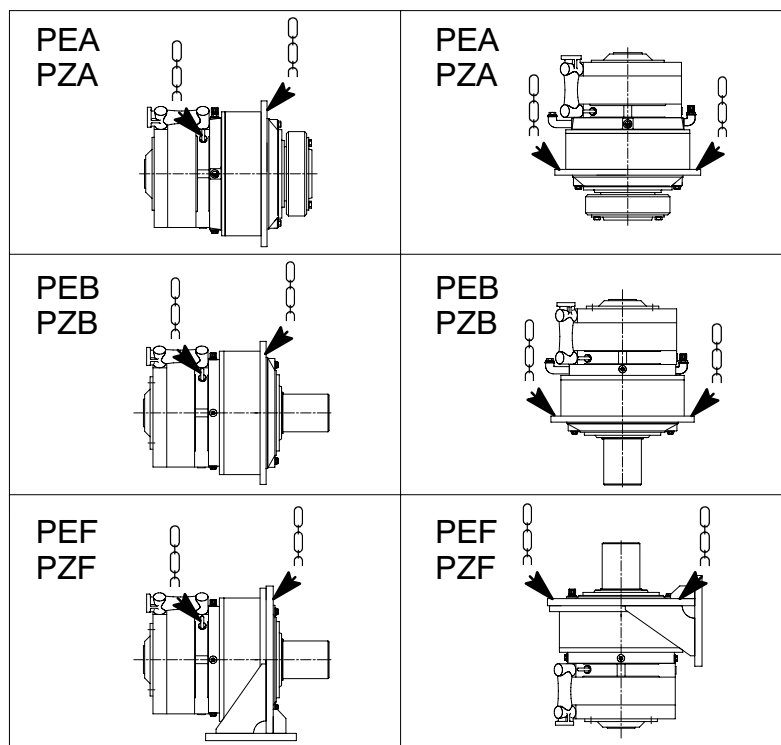

A detailed view of the gear unit can be obtained from the drawings in the gear-unit documentation.

4.3 Storing the gear unit

The gear unit must be stored in the position of use in a sheltered place. It must be placed on a vibration-free wooden base and covered over.



Do not stack gear units on top of one another.

Caution!

If the gear unit is being stored out of doors, it must be particularly carefully covered, and care must be taken that neither moisture nor foreign material can collect on the unit.

Note: Unless otherwise agreed by contract, the gear units must not be exposed to harmful environmental factors such as chemically aggressive products.

Provision for special environmental conditions during transport (e.g. transport by ship) and storage (climate, termites, etc.) must be contractually agreed.

4.4 Standard corrosion protection

The gear unit is provided with an interior preservative agent. The free shaft ends are painted for protection.

The outer paint coating is resistant to dilute acids, alkalis, oils and solvents. It is also resistant to sea water, tropical conditions and temperatures up to 140 °C.

Note: Ensure that the paint is not damaged!
Mechanical damage (scratches), chemical damage (acids, alkalis) and thermal damage (sparks, welding beads, heat) cause corrosion which may cause failure of the external protective coating.

Unless otherwise contractually agreed, the interior preservation and the preservation of the free shaft ends are guaranteed for 24 months, provided that storage is in dry, frostfree sheds and that the gear unit is duly sealed. The period of validity of the guarantee starts on the date of delivery of the gear unit.

For longer periods of storage (> 24 months) we advise regular checking and, if necessary, renewal of the interior preservation (see section 7, "Start-up"). The output shaft must be rotated at least one turn to change the position of the rolling element in the bearings. The input shaft must not come to a standstill in the same position as before rotation. This procedure must be repeated and documented every 24 months until start-up.

5. Technical description

Observe the "Safety instructions" in section 3!

5.1 General description

The combined gear unit consists of one or two planetary stages with a hydraulic motor added-on on the input side. The combined gear unit is designed for a horizontal and vertical mounting position. If desired, the combined gear unit can also be supplied for a different mounting position.

Note: The enclosed operating instructions for the hydraulic motor must be observed.

It can be operated in both directions of rotation.

Depending on type and size, gear units of the standard programme can be equipped with right angle oil level indicator, backstop and torque arm.

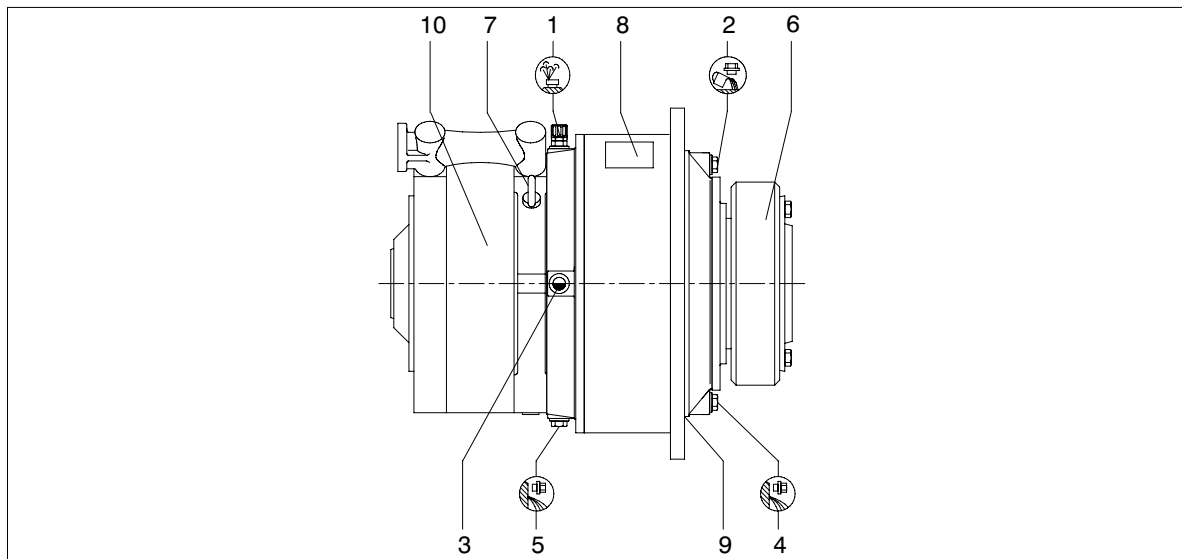





- | | | | |
|---|-----------------------------|----|----------------------------------|
| 1 | Housing ventilation | 6 | Shrink disk |
| 2 | Oil inlet | 7 | Lifting eyes / ring bolts |
| 3 | Oil sight glass / oil level | 8 | Rating plate |
| 4 | Oil drain | 9 | Mounting position for torque arm |
| 5 | Residual-oil drain | 10 | Radial piston motor |

A detailed view of the gear unit can be obtained from the drawings in the gear-unit documentation.

5.2 Housing

The gear unit housing is made of cast iron; the housing flange is made of nodular cast iron. If necessary, the housing may also be made of grey cast iron or steel.

Colour codes for ventilating, oil inlet, oil level and oil drainage:

Ventilating:	yellow	
Oil inlet:	yellow	
Oil level:	red	
Lubrication points:	red	
Oil drain:	white	

5.3 Toothed components

Externally toothed spur gears are made of case-hardening steel 18CrNiMo7. The tooth flanks are case-hardened and ground.

Depending on size, the internal gear teeth are made of heat-treatable steel or bainitic nodular cast iron. The teeth are shaped, milled or ground (depending on size).

5.4 Lubrication

The teeth and rolling bearings of the gear units are adequately supplied with oil by splash lubrication. For special mounting positions and/or gear units requiring additional cooling it may be necessary to provide pressure-feed or oil circuit lubrication.

Note: For safety reasons, the gear unit is supplied without oil filling for transport.

Depending on the mounting position, it is possible that the bearings are not lubricated by the gear unit oil. In such cases, these bearings are lubricated with lithium-base grease.

Note: Do not mix greases of different soap bases when relubricating.

5.5 Shaft bearings

All shafts are mounted in rolling bearings.

5.6 Shaft seals, static seals

As a rule radial shaft sealing rings are used as standard seals. They are fitted preferably with an additional dust lip to protect the actual sealing lip from external contamination.

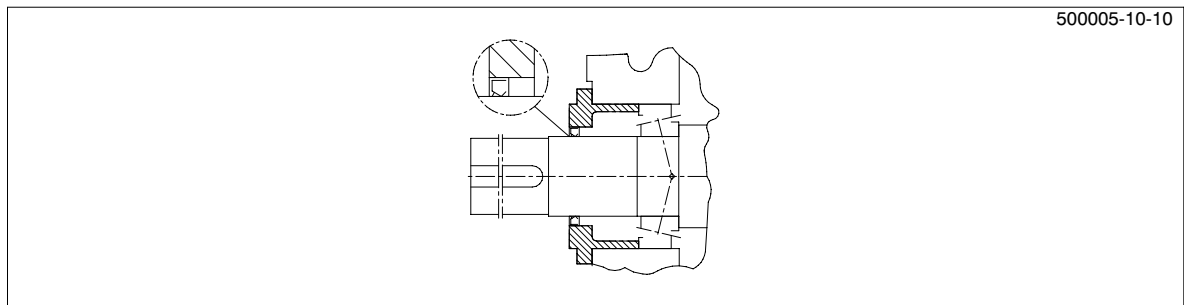

Alternatively, and depending on the order, it is also possible to provide the gear units with regreasable labyrinth seals to prevent the ingress of dust (Taconite seal).

The individual housing components are sealed statically with Loctite 640 to prevent leakages.

5.7 Couplings

As a rule, a flexible coupling must be provided for the gear unit output.

If a rigid coupling or another element is used which gives rise to additional radial and/or axial forces, this must be agreed by contract.

Caution!

Couplings with peripheral velocities on the outer diameter of up to 30 m/s must be statically balanced. Couplings with peripheral velocities over 30 m/s must be dynamically balanced.

For maintenance and operation of the couplings, refer to the specific operating instructions for the coupling.

Note: When installing the drives, the individual components must be very precisely aligned with one another in order to minimise restoring forces caused by angle and shaft offset and avoid premature wear to flexible coupling components.

5.8 Shrink disk

In the case of a shaft mounting gear unit, a shrink disk should be used as a frictional clamping connection between the gear unit hollow shaft and machine.

5.9 Backstop

For certain requirements, the gear unit is fitted with a mechanical backstop. This permits only the correct direction of rotation during the operation of the unit. The direction of rotation is marked by an arrow on the input side of the gear unit.

The backstop is mounted oiltight on an adapter flange on the gear unit and integrated in its oil-circulation system.

The backstop is fitted with centrifugally operated sprags. When the gear unit is running in the specified direction, the inner ring and the cage with the sprags also rotates while the outer ring remains stationary. From a certain speed of rotation, the grippers lift off and the backstop now operates without wear.

Note: The direction of rotation can be changed by reversing the cage. FLENDER must be consulted in all cases on this matter.

Caution!

To prevent damage to or destruction of the backstop, it is essential to ensure that the motor is not run in opposition to the locked backstop. Observe the sign fixed to the gear unit.

6. Fitting

Observe the "Safety instructions" in section 3!

6.1 General information on fitting

Note: When installing the hydraulic motor, observe the operating instructions for this motor.

Fitting work must be done with great care by trained and qualified personnel. The manufacturer cannot be held liable for damage caused by incorrect assembly and installation.

During the planning phase sufficient space must be allowed around the gear unit for later care and maintenance work.

Adequate lifting equipment must be available before beginning the fitting work.

Caution!

Exposure to direct sunlight may cause overheating. Protective features such as covers, roofing, etc. must be provided as required! The operator should ensure that no foreign bodies affect the proper function of the gear unit (e.g. falling objects or heaping over).

Caution!

No welding work must be done on the drive. The drives must not be used as an earthing point for welding operations. Toothed parts and bearings may be irreparably damaged by welding.

Caution!

All the fastening points provided by the design of the unit must be used. Screws which have been damaged during assembly or disassembly work must be replaced with new ones of the same strength class and type.

To ensure proper lubrication, the installation position specified in the order must always be observed.

6.2 Foundation

The foundation must be horizontal and level.

It must be designed in such a way that no resonance vibrations are set up and that no vibrations are transmitted from adjacent foundations. The structure on which the unit is to be mounted must be rigid. It must be designed according to the weight and torque, taking into account the forces acting on the gear unit.

Note: For dimensions, space requirement, arrangement of supply connections (e.g. with separate oil-cooling units), refer to the drawings in the gear-unit documentation.

6.3 Description of installation work

- Remove corrosion protection coat from the solid shaft, the hollow shaft and the machined add-on surfaces with a suitable cleaning medium.



**Adequate ventilation must be ensured, when using cleaners containing solvent additives.
No open flames! Danger of explosion!
Observe current regulations.**

Caution!

The cleaner must not be allowed to come in contact with the shaft sealing rings.

- Mount and secure output drive elements (e.g. coupling components) on shafts.
If these are to be heated before mounting, refer to the dimensioned drawings in the coupling documentation for the correct joining temperatures.

Unless otherwise specified, the components may be heated inductively, with a burner or in a furnace.



Take precautions to avoid burns from hot components!

Caution!

**Protect shaft sealing rings from damage and heating to over + 100 °C
(use heat-protective screens to protect against radiant heat.)**

Caution!

**The coupling components must be fitted with the aid of suitable equipment to avoid damaging the shaft bearings through axial joining forces.
Always use suitable lifting equipment.
When fitting the components, care must be taken that the shaft sealing rings and shaft running surface are not damaged.**

The components must be pushed smartly onto the shaft up to the position specified in the order-specific dimensioned drawing.

Caution!

Fit the coupling with the aid of suitable fitting equipment. Never use force or knock the couplings into position, as this may damage the gearwheels, rolling bearings, locking rings, etc.

Note: Gear units whose weight requires the use of lifting gear must be attached as shown in section 4, "Transport, handling and storage". When add-on parts are mounted on the gear unit, appropriate additional attachment points must be provided in accordance with the order-specific dimensioned drawing.

6.4 Shrink disk

6.4.1 Fitting the shrink disk

The shrink disk is delivered ready for installation.

Caution! It must not be dismantled before clamping for the first time.

Caution! The bore of the hollow shaft and the machine shaft must be absolutely free of grease in the area of the shrink disk seat. This is essential for safe and reliable torque transmission. Do not use contaminated solvents or dirty cloths for removing grease.

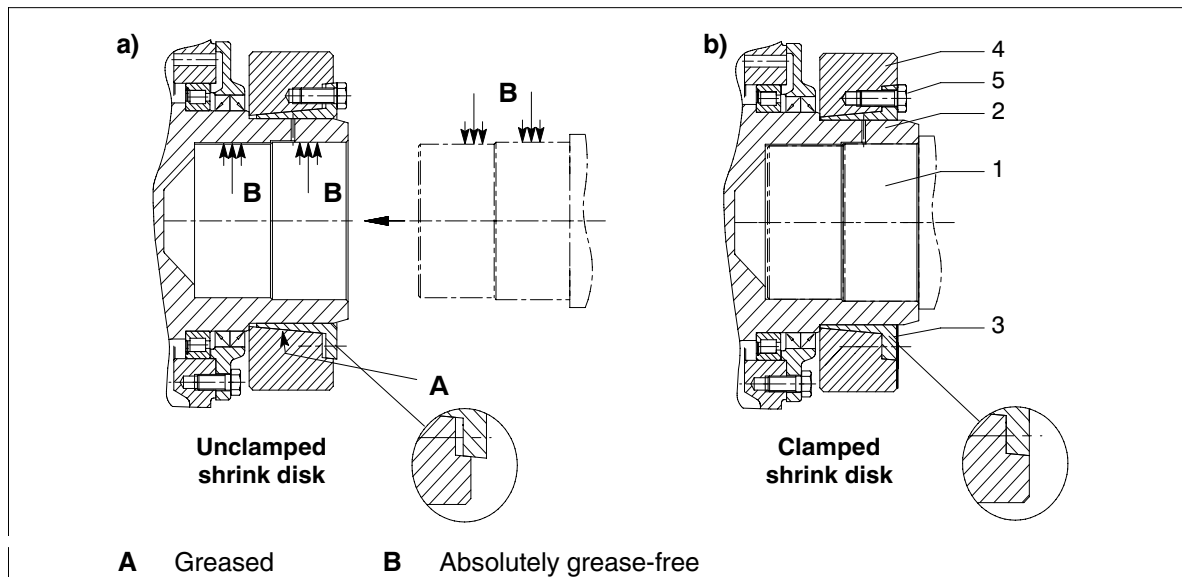

1 Machine shaft
2 Hollow shaft

3 Inner ring
4 Outer ring

5 Tensioning bolt

- Mounting the shaft or fitting the hub onto the shaft



If the gear unit is fitted in a vertical position with the output shaft down, the fitted shrink disk must be protected from dropping.

Note: The outer surface of the hollow shaft may be greased in the area of the shrink disk seat.

Caution! Do not tighten the tensioning bolts until the machine shaft is installed.

Tighten all the tensioning bolts gradually one after the other, working round several times.

Caution! Do not tighten diametrically opposite bolts one after the other. Tighten the tensioning bolts until the front surfaces of the inner and outer rings are aligned (see fig. b)).

Note: This allows the clamping condition to be checked visually.

Caution! To avoid overloading the individual bolts, the maximum tensioning torque (see table 6.1) must never be exceeded. The alignment of the front surfaces has priority. If alignment cannot be achieved by clamping, consult FLENDER.

FLENDER

Tensioning-bolt thread	Max. tensioning torque per bolt (with $\mu = 0.1$)		Tensioning-bolt thread	Max. tensioning torque per bolt (with $\mu = 0.1$)	
	Strength class			Strength class	
	10.9 Nm	12.9 Nm		10.9 Nm	12.9 Nm
M 6	12	14.5	M 20	470	570
M 8	29	35	M 24	820	980
M 10	58	70	M 27	1210	1450
M 12	100	121	M 30	1640	1970
M 14	160	193	M 33	2210	2650
M 16	240	295	M 36	2850	3420

Table 6.1: Maximum torques for tensioning bolts



For safety reasons, a protective cover should be mounted above the shrink disk.

6.4.2 Demounting and remounting the shrink disk

Disassemble the protective cover.

The releasing process is similar to that of clamping.

To enable the stored energy of the outer ring during disassembly to be lowered slowly via the bolts to be loosened, the bolts must be loosened evenly and in sequence, initially only by a quarter turn.

Caution! Under no circumstances must the bolts be loosened one after the other.

If after loosening all the bolts approx. one turn the outer ring does not come free of the inner ring of its own accord, the outer ring can be detensioned with the forcing threads by screwing some of the adjacent fastening bolts into them. The now loosening outer ring is braced against the remaining bolts. This operation must be carried out until the outer ring releases of its own accord.

Releasing is then possible without difficulty.

Pull the shrink disk off the hollow shaft.

Caution! The hollow shaft of the gear unit can be provided with an additional oil hole for injecting oil for demounting the hollow shaft from the machine shaft. When using this hole, observe the maximum permissible pressures shown in the drawings of the gear-unit documentation.

6.4.2.1 Cleaning and greasing the shrink disk

Released shrink disks do not have to be dismantled and re-greased before being re-clamped.

The shrink disk should only be dismantled and cleaned if it is dirty.

Caution! Following cleaning, only the inner sliding surfaces of the shrink disk should be re-greased.

Use a solid lubricant with a high MoS₂-based molybdenum disulphide content and with a coefficient of friction of $\mu = 0.04$ according to the following table.

Lubricant	Form	Manufacturer
Molykote 321 R (lubricating paint)	Spray	DOW Corning
Molykote Spray (powder spray)	Spray	DOW Corning
Molykote G Rapid	Spray or paste	DOW Corning
Aemasol MO 19 P	Spray or paste	A. C. Matthes
Molykombin UMFT 1	Spray	Klüber Lubrication
Unimoly P 5	Powder	Klüber Lubrication

Table 6.2: Lubricants for shrink disk after cleaning

6.5 Installation of the torque arm

Note: For all shaft mounting gear units, the reaction torque corresponding to the torque of the machine and acting in an opposite direction on the housing must be absorbed.

6.5.1 One-sided torque arm

In the case of a one-sided torque arm, a ball and socket joint (see figure 1) or a flexible bush should be provided.

Caution!

The screw-on surface of the torque arm on the gear unit housing must be degreased and smeared with Loctite 640. This increases the reliability of the torque transmission and protects against corrosion.

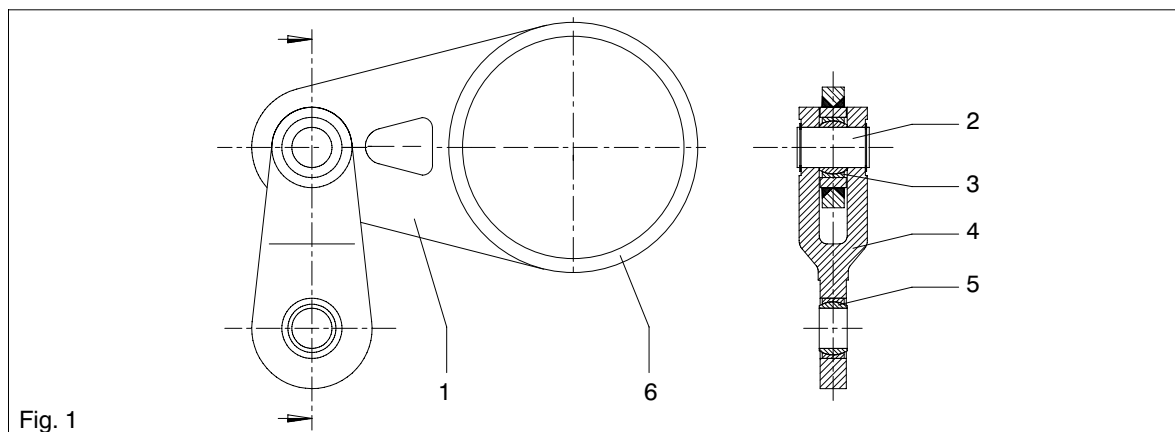

Fig. 1

- | | | | | | |
|---|----------------------|---|-----------------------|---|-----------------------|
| 1 | One-sided torque arm | 3 | Ball and socket joint | 5 | Ball and socket joint |
| 2 | Axle | 4 | Lever | 6 | Gear unit connection |

For a detailed view, refer to the drawings in the gear unit documentation.

6.5.2 Double-sided torque arm

In the case of a double-sided torque arm, if any, the torque is supported by bars and joints on a torsion shaft. The screw-on surface of the torque arm on the gear unit should be treated as described under 6.5.1.

This type of construction ensures that the machine bearings are freed from any shearing forces, except for the weights. Figure 2 shows a possible variant.

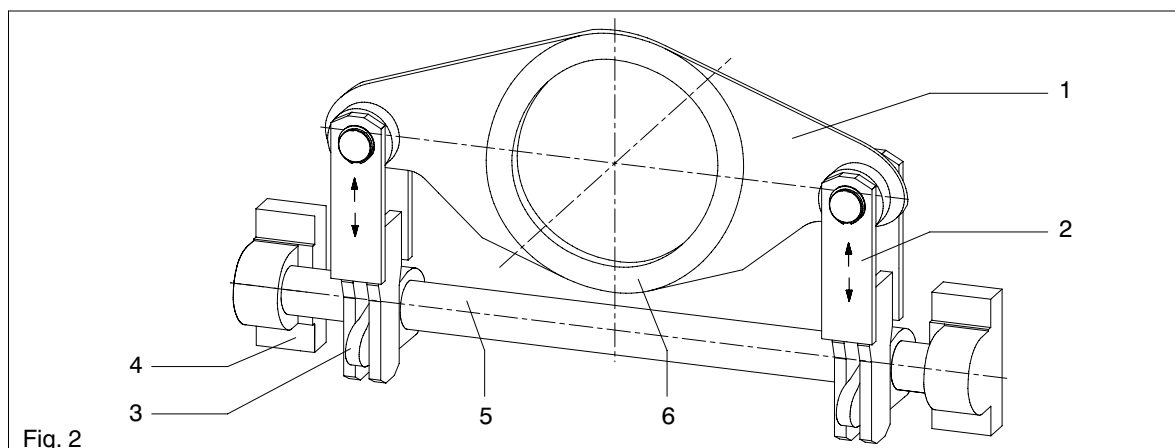

Fig. 2

- | | | | | | |
|---|-------------------------|---|------------------|---|----------------------|
| 1 | Double-sided torque arm | 3 | Joint component | 5 | Torsion shaft |
| 2 | Bar | 4 | Bearing pedestal | 6 | Gear unit connection |

For a detailed view, refer to the drawings in the gear unit documentation.

The bearing pedestals may be mounted both to a vertical wall (as illustrated) and on a horizontal foundation.

6.6 Final work

Caution!

After installation of the gear unit check all screw connections for tight fit.

In addition, after tightening the fixings a check must be made to see that the alignment has not changed.

Check by means of the list of equipment as well as the associated drawings whether all units which may have been removed for transport have been refitted.

Oil drain cocks, if any, must be secured against accidental opening.

The gear unit must be protected against falling objects.

Protective devices for rotating parts must be checked for correct seating. Contact with rotating parts is not permitted.

7. Start-up

Observe the "Safety instructions" in section 3!

7.1 Procedure before start-up

Note: When starting up the hydraulic motor for the first time, observe the operating instructions for this motor.

7.1.1 Removal of preservative agent

- Unscrew and open oil drain plug and drain remaining preservative agent or running-in oil from the housing into a suitable container and dispose of in accordance with regulations. Any residual-oil drain plugs should also be opened. The location of the oil draining point is marked by an appropriate symbol in the dimensioned drawing in the gear-unit documentation.



Remove any oil spillage immediately with an oil-binding agent.

- Screw in the oil drain plug.

Caution!

Before start-up, replace the yellow plastic plug with a breather screw with cap (see also notice on gear unit).



The oil must not come into contact with the skin (e.g. the operator's hands). The safety notes on the data sheets for the oil used must be observed here!

7.2 Filling with lubricant

- Open oil filler plug.

Caution!

Fill the gear unit with fresh oil of the grade specified on the rating plate, using a filter (max. mesh 25 µm).

Note:

The quality of the oil used must meet the requirements of the separately enclosed BA 7300 EN operating instructions, otherwise the guarantee given by FLENDER will lapse. We urgently recommend using one of the oils listed in BA 7300 EN, because they have been tested and meet the requirements.

Information on the type, quantity and viscosity of the oil is given on the rating plate on the gear unit.

The quantity of oil indicated on the rating plate is an approximation only. The quantity of oil to be put in is shown by the marks on the oil sight glass or on the right angle oil level indicator.

Note:

In the case of gear units with an oil cooling system, the oil circuit should also be filled up. To do so, the gear unit should be started and then run briefly, as described in Section 8.

- Check oil level on the oil sight glass or right angle oil level indicator.

Note:

The oil level should be up to the mid of the oil sight glass or the mid of the markings on the angular oil level indicator.



Remove any oil spillage immediately with an oil-binding agent.

The oil must not come into contact with the skin (e.g. the operator's hands).

The safety notes on the data sheets for the oil used must be observed here!

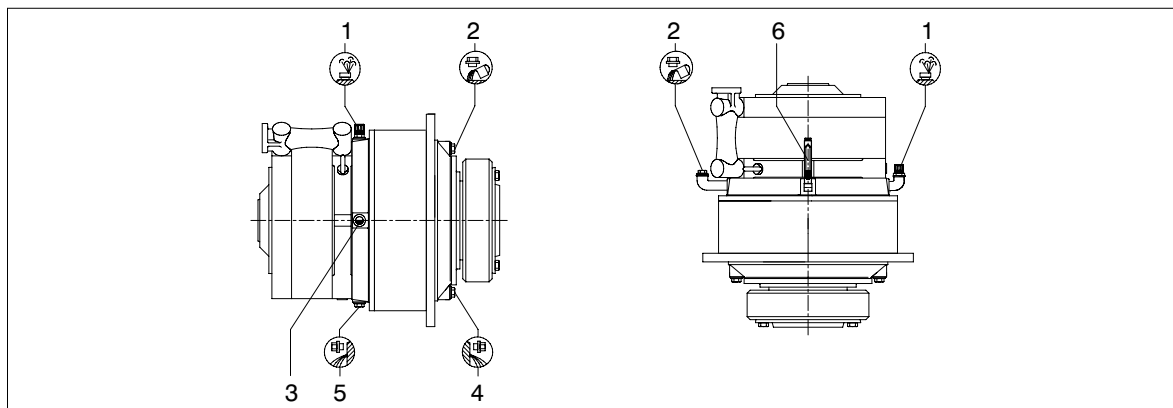

- 1 Housing ventilation
- 2 Oil filler plug
- 3 Oil-sight glass

- 4 Oil drain
- 5 Residual-oil drain
- 6 Angular oil level indicator

A detailed view of the gear unit can be obtained from the drawings in the gear-unit documentation.

- Screw in oil filler plug.

7.3 Start-up

- Check the oil level in the gear unit.

Note:

When the oil has cooled down, the oil level should be up to the middle of the oil sight glass or up to the middle marks on the right angle oil level indicator. If the oil is hot, the marks may be slightly exceeded. It must not be allowed to fall below the mark. If necessary, top oil up to the correct level.

7.4 Gear unit with backstop

Before start-up, check whether the backstop can be turned manually in the free-running direction without exerting undue force. When doing so, note the direction of rotation arrow on the gear unit.

Caution!

To prevent damage to or destruction of the backstop, it is essential to ensure that the motor is not run in opposition to the locked backstop. Observe the sign fixed to the gear unit.

7.5 Removal from service

- To take the gear unit out of service, first switch off the drive unit.



Secure the drive unit to prevent it from being started up unintentionally. Attach a warning notice to the start switch!

- During longer periods of disuse, start the unit up briefly at intervals of approx. 3 weeks. If the gear unit is to remain out of service for longer than six months, it must be treated with preservative agent (see item 7.5.1).

7.5.1 Interior preservation during longer disuse

Depending on the type of lubrication or shaft sealing, the following types of interior preservative agent can be used.

7.5.1.1 Interior preservation with gear oil

Gear units with splash lubrication systems and contacting shaft seals can be filled with the correct type of oil up to a point just below the breather screw.

7.5.1.2 Interior preservation with preservative agent

Before longer periods of storage gear units with pressure lubrication systems, oil circulation cooling or non-contacting shaft seals should be filled with preservative agent and run without load.

Interior preservation procedure:

- Switch the gear unit off and drain the oil as described in section 10, "Maintenance and repair".
- Fill conservation agent in accordance with table 7.1 or 7.2, as appropriate, up to the middle of the oil sight glass or up to the mark on the right angle oil level indicator.
- Start the gear unit and allow it to idle briefly.
- Unscrew the oil drain plug and allow the preservative agent to drain into a suitable container and dispose of it according to regulations.



There is a risk of scalding from the hot preservative agent draining from the gear unit. Wear protective gloves!

- Screw in the oil drain plug.

Caution!

Before re-starting the gear unit replace the screw plug with the breather screw or air filter. Observe also item 7.1.1.

FLENDER

Duration of protection	Preservative agent	Special measures
up to 6 months	Castrol Alpha SP 220 S	none
up to 24 months		Close gear unit, replace breather screw or air filter with a yellow plug screw (replace the original parts before start-up). Storage in enclosed dry rooms.
For storage periods longer than 24 months, renew the preservative agent. For storage periods longer than 36 months, FLENDER should be consulted before.		

Table 7.1: Preservation procedure when using mineral oil or PAO-based synthetic oil

Duration of protection	Preservative agent	Special measures
up to 6 months	Special anti-corrosion oil TRIBOL 1390 1)	none
up to 36 months		Close gear unit, replace breather screw or air filter with a yellow plug screw (replace the original parts before start-up). Storage in enclosed dry rooms.
For storage periods longer than 36 months, FLENDER should be consulted before.		

Table 7.2: Preservation procedure when using PG-based synthetic oil

1) Resistant to tropical conditions and sea water. Max. ambient temperature 50 °C

7.5.2 Exterior preservation

Exterior preservation procedure:

- Clean the surfaces.
- For separation between the sealing lip of the shaft sealing ring and the preservative agent, the shaft should be brushed with grease in way of the sealing lip.
- Apply preservative agent.

Duration of protection	Preservative agent	Layer thickness	Remarks
up to 36 months	Tectyl 846 K19	approx. 50 µm	Long-term wax-based preservative agent, resistant to sea water and tropical conditions (soluble with CH compounds) Storage in enclosed dry rooms.

Table 7.3: Exterior preservation of shaft ends and other bright machined surfaces

8. Operation

Observe the "Safety instructions" in section 3, the instructions in section 9, "Faults, causes and remedy", and in section 10, "Maintenance and repair"!

Note: When operating the hydraulic motor, observe the operating instructions for this motor.

• During operation the unit must be monitored for:

- Oil temperature (The gear unit is designed for a temperature of 90 °C with mineral oil in continuous operation. For higher temperatures, synthetic oils must be used. The maximum short-term operating temperature is 100 °C. See also section 10.)
- Changes in gear noise
- Possible oil leakage at the housing and shaft seals
- Correct oil level (see section 7, "Start-up")

Note: To check the oil level, stop operation of gear unit. When the oil has cooled down, the oil level should be up to the middle of the oil sight glass or up to the middle marks on the right angle oil level indicator. If the oil is hot, the marks may be slightly exceeded. It must not be allowed to fall below the mark. If necessary, top oil up to the correct level.

Caution!

If any irregularities are noticed during operation or if the pressure monitor in the oil-cooling system (if installed) triggers the alarm, switch the drive unit off at once. Determine the cause of the fault, using the table in section 9.

The trouble-shooting table contains a list of possible faults, their causes and suggested remedies.

If the cause cannot be identified or the unit repaired with the facilities available, you are advised to contact one of our customer-service offices for specialist assistance (see section 11).

9. Faults, causes and remedy

Observe the "Safety instructions" in section 3 and the instructions in section 10, "Maintenance and repair"!

Note: For possible faults in the hydraulic motor, refer to the operating instructions for this motor.

9.1 General information on faults and malfunctions

Note: Faults and malfunctions occurring during the guarantee period and requiring repair work on the gear unit must be carried out only by FLENDER Customer Service. In the case of faults and malfunctions occurring after the guarantee period and whose cause cannot be precisely identified, we advise our customers to contact our customer service.

Caution!

FLENDER will not be bound by the terms of the guarantee or otherwise be responsible in cases of improper use of the gear unit, modifications carried out without FLENDER's agreement or use of spare parts not supplied by FLENDER.



To remedy faults and malfunctions, the gear unit must always be taken out of service.

Secure the drive unit to prevent it from being started up unintentionally.

Attach a warning notice to the start switch!

9.2 Possible faults

Faults	Causes	Remedy
Changes in gear noise.	Damage to gear teeth.	Contact Customer Service. Check all toothed components and replace any damaged parts.
	Excessive bearing play.	Contact Customer Service. Adjust bearing play.
	Bearing defective.	Contact Customer Service. Replace defective bearings.
	Grind labyrinth rings.	Readjust labyrinth rings.
Loud noises in area of gear-unit fastening.	Fastening has worked loose.	Tighten bolts / nuts to specified torque. Replace damaged bolts / nuts.
Increased temperature at the bearing points.	Oil level in housing too low.	Check oil level at room temperature and, if necessary, top up oil.
	Oil too old.	Check date of last oil change and, if necessary, change oil. See section 10.
	Bearing defective.	Contact Customer Service. Check and, if necessary, replace bearings.
Gear unit is oiled up.	Inadequate sealing of housing covers or joints.	Seal joints.
	Labyrinth seals oiled up.	Check oil filling. If necessary, clean labyrinth seals.
Oil leakage from gear unit.	Inadequate sealing of housing covers or joints.	Check and, if necessary, replace seals. Seal joints.
	Radial shaft sealing rings defective.	Check radial shaft sealing rings and, if necessary, replace.
Oil foams.	Water in oil.	Test the oil, change oil if necessary.
	Oil too old (defoaming agent used up).	Test the oil, change oil if necessary.
	Unsuitable oils mixed up.	Test the oil, change oil if necessary.
Water in oil.	Oil foams in sump.	Check state of oil by the test-tube method for water contamination. Have oil analysed by laboratory.
	Defective oil cooler.	Repair or replace oil cooler. Fill with oil, look for and repair any leaks.
	Gear unit exposed to cold air from machine-room ventilator: water condensing.	Protect gear unit with suitable heat insulation. Close air outlet or alter its direction by structural measures.

FLENDER

Faults	Causes	Remedy
Increased operating temperature.	Oil level in housing too high.	Check oil level and, if necessary, adjust.
	Oil too old.	Check date of last oil change and, if necessary, change oil. See section 10.
	Oil badly contaminated.	Change oil. See section 10.
	Gear unit with water oil-cooler: Coolant flow too low.	Fully open valves in in- and outflow pipes. Check for free flow through water oil-cooler.
	Coolant temperature too high.	Check temperature and, if necessary, adjust.
	Oil flow through water oil-cooler too low due to: Badly clogged oil filter.	Cleaning the oil filter. See section 10.
Fault in oil-supply system.		Consult operating instructions for oil-supply system.

Table 9.1: Faults, causes and remedies

10. Maintenance and repair

Observe the "Safety instructions" in section 3 and the instructions in section 9, "Faults, causes and remedy"!

Note: For information on maintenance of the hydraulic motor, refer to the operating instructions for this motor.

10.1 General notes on maintenance

Maintenance and repair work must be done with care and by duly trained and qualified personnel only.

The following applies to all work in item 10.2:



Switch gear unit and add-on components off.

Secure the drive unit to prevent it from being started up unintentionally. Attach a warning notice to the start switch!

Caution!

The periods indicated in table 10.1 depend on the conditions under which the gear unit is operated. Only average periods can therefore be stated here. These refer to:

a daily operating time of	24 h
a duty factor of	100 %
a maximum oil temperature of	90 °C (mineral oil only)
	100 °C (synthetic oil only)

Note: Under different operating conditions the periods indicated below must be adjusted accordingly.

Measures	Periods	Remarks
Checking oil temperature	Daily	
Checking for unusual gear-unit noise	Daily	
Checking oil level	Monthly	Oil level up to the middle of the oil sight glass or up to the middle of the mark on the right angle oil level indicator
Checking gear unit for leaks	Monthly	
Testing oil for water content	After approx. 400 operating hours, once per year at least	See Item 10.2.1
First oil change after start-up	After approx. 400 operating hours	See Item 10.2.2
Subsequent oil changes	Every 18 months or 5 000 operating hours 1)	See Item 10.2.2
Cleaning the breather screw	Every 3 months	See Item 10.2.3
Refilling Taconite seals with grease	Every 3 000 operating hours or every 6 months at least	See Item 10.2.4
Cleaning gear-unit housing	Simultaneously with oil change	See Item 10.2.5
Checking condition of water oil-cooler	Simultaneously with oil change	See Item 10.2.6
Checking tightness of fastening bolts	After first oil change, then after every second oil change	See Item 10.2.8
Checking the preservation of the free shaft ends	Every 3 years	See Item 7.5.2
Carrying out complete inspection of gear unit	Approx. every 2 years simultaneously with due oil change	See Item 10.3.1

Table 10.1: Maintenance and repair work

1) When using synthetic oils and depending on the individual application, the periods can be extended.

10.2 Description of maintenance and repair work

10.2.1 Testing water content of oil

For detailed information on testing the oil for water content apply to the lubricant manufacturer.

10.2.2 Changing the oil

- The instructions in item 7.1 must be observed!
- Close the stop valves in the coolant in- and outflow pipes (for gear units with water oil-cooling system)
- Drain the oil while it is still warm, i.e. immediately after shutting down the machinery.

Caution!

When changing the oil, always re-fill the gear unit with the same type of oil. Never mix different types of oil or oils made by different manufacturers. If nevertheless a different type of oil is changed to, the gear unit must be flushed through with the new type of oil.

When changing the oil, the housing must be flushed with oil to remove sludge, metal particles and oil residue. Use the same type of oil as is used for normal operation. High-viscosity oils must be heated beforehand. Ensure that all residues have been removed before filling with fresh oil.

- Place a suitable container under the oil drain plug of the gear-unit housing.
- Unscrew the breather screw on the top of the housing.
- Unscrew the oil drain plug and allow the oil to drain into the container.



There is a danger of scalding from the hot oil emerging from the housing. Wear protective gloves. Remove any oil spillage immediately with an oil-binding agent.

- Clean the permanent magnet of the oil drain plug thoroughly.
- Screw in the oil drain plug.

Note: Check the condition of the sealing ring (the sealing ring is vulcanised onto the oil drain plug); if necessary, use a new oil drain plug.

- Open oil filler plug.

Note: Check the condition of the sealing ring (the sealing ring is vulcanised onto the oil drain plug); if necessary, use a new oil drain plug.

- Fill with lubricant according to item 7.2.

10.2.3 Cleaning the breather screw

If a layer of dust has built up, the breather screw must be cleaned, whether or not the minimum period of 3 months has expired. To do this, the breather screw must be unscrewed, cleaned with benzine or similar agent and dried. It can also be cleaned by blowing out with compressed air.

10.2.4 Refilling Taconite seals with grease

- Inject approx. 30 g lithium-based bearing grease (refer to Ident no. H13 in the FLENDER BA 7300 EN operating instructions) into the lubrication points of the Taconite seal. The lubrication points are fitted with flat grease nipples type AM10x1 to DIN 3404.



Remove and dispose of any old grease escaping.

10.2.5 Cleaning the gear unit

- Remove any dirt adhering to the housing with a hard brush.
- Remove any corrosion.

Caution!

To prevent the build-up of dust on the gear unit, cleaning must be done in accordance with operating conditions.

The gear unit must not be cleaned with high-pressure cleaning equipment.

10.2.6 Check oil cooling system

- Close the stop valves in the coolant in- and outflow pipes.
- Inspect cooler for leaks in the piping.
- Check the condition of screw connections and, if necessary, replace.

Note: For operation and maintenance, always observe the operating instructions indicated in the order-specific appendix.
For technical data, refer to the order-specific list of equipment.

10.2.7 Topping up oil

- The instructions in item 7.2 must be observed!
- Always top up with the same type of oil as already used (see also item 10.2.2).

10.2.8 Checking tightness of fastening bolts

- The instructions in item 10.1 must be observed!
- Check tightness of all fastening bolts with a torque wrench.

Thread size	Tightening torque	Initial tensioning force
M 42	4070 Nm	526000 N
M 48	6140 Nm	693000 N
M 56	9840 Nm	959000 N
M 64	14300 Nm	1268000 N
M 72 x 6	20800 Nm	1600000 N
M 80 x 6	28900 Nm	1950000 N
M 90 x 6	41650 Nm	2550000 N
M 100 x 6	57800 Nm	3200000 N

Table 10.2: Tightening torques and initial tensioning forces of the foundation bolts

All other bolts on the gear unit should be checked for tightening torques according to the following table:

Thread size	Tightening torque (with $\mu = 0.14$) Strength class		Thread size	Tightening torque (with $\mu = 0.14$) Strength class	
	8.8	10.9		8.8	10.9
	M 10	49 Nm		69 Nm	M 36
M 12	86 Nm	120 Nm	M 42	4070 Nm	5720 Nm
M 16	210 Nm	295 Nm	M 48	6140 Nm	8640 Nm
M 20	410 Nm	580 Nm	M 56	9840 Nm	13850 Nm
M 24	710 Nm	1000 Nm	M 64	14300 Nm	21000 Nm
M 30	1450 Nm	2000 Nm			

Table 10.3: Tightening torques



Damaged bolts must be replaced with new bolts of the same type and strength class.

10.3 Final work

The final work is to be done in accordance with the instructions in item 6.6.

10.3.1 General inspection of gear unit

The general inspection of the gear unit should be carried out by the FLENDER Customer Service, as our engineers have the experience and training necessary to identify any components requiring replacement.

10.4 Lubricants

The quality of the oil used must meet the requirements of the separately enclosed BA 7300 EN operating instructions, otherwise the guarantee given by FLENDER will lapse. We urgently recommend using one of the oils listed in BA 7300 EN, because they have been tested and meet the requirements.

Note: To avoid misunderstandings, we should like to point out that this recommendation is in no way intended as a guarantee of the quality of the lubricant supplied. Each lubricant manufacturer is responsible for the quality of his own product.

Information on the type, quantity and viscosity of the oil is given on the rating plate on the gear unit or in the supplied documentation.

The quantity of oil indicated on the rating plate is an approximation only. The marks on the dipstick or oil sight glass are decisive for the amount of oil to be filled in.

The use instructions for lubricants currently recommended by FLENDER are also available on the Internet at "<http://www.flender.com>".

The oils listed there are subjected to continuous tests. Under certain circumstances the oils recommended there may therefore later be removed from the range or replaced with further developed oils.

We recommend regularly checking whether the selected lubricating oil is still recommended by FLENDER. If it is not, the brand of oil must be changed.

11. Spare parts, customer-service addresses

11.1 Stocking spare parts

By stocking the most important spare and wearing parts on site you can ensure that the gear unit is ready for use at any time.

To order spare parts, refer to the spare-parts list.

For further information refer to the spare-parts drawing stated in the list.

We guarantee only the original spare parts supplied by us.

Caution!

Please note that spare parts and accessories not supplied by us have not been tested or approved by us. The installation and/or use of such products may therefore impair essential characteristics of the gear unit, thereby posing an active or passive risk to safety. FLENDER will assume no liability or guarantee for damage caused by spare parts and accessories not supplied by FLENDER.

Please note that certain components often have special production and supply specifications and that we supply you with spare parts which comply fully with the current state of technical development as well as current legislation.

When ordering spare parts, always state the following:

Order no. / Item	Type / Size	Part no.	Quantity
------------------	-------------	----------	----------

11.2 Spare parts and customer-service addresses

When ordering spare parts or requesting a Service fitter, please contact FLENDER first.

Adressen - Deutschland

(2008-05-08)

Hauptsitz

A. Friedr. Flender AG	Alfred-Flender-Straße 77 46395 Bocholt	Postfach 1364 46393 Bocholt	Tel.: (0 28 71) 92 - 0 Fax: (0 28 71) 92 - 25 96	contact@flender.com www.flender.com
------------------------------	--	---------------------------------------	---	--

Regionen Deutschland

Siemens AG Automation and Drives RD - Hanse Niederlassung Hamburg	Lindenplatz 2	20099 Hamburg	Tel.: (0 40) 28 89 - 20 60 Fax: (0 40) 28 89 - 26 11	elke.heilemann @siemens.com www.automation.siemens.com/hse
Siemens AG Automation and Drives RD - Ost Niederlassung Berlin	Nonnendammallee 101	13629 Berlin	Tel.: (0 30) 3 86 - 3 09 95 Fax: (0 30) 3 86 - 3 21 16	andreas.klawisch @siemens.com www.automation.siemens.com/ost
Siemens AG Automation and Drives RD - Mitte Niederlassung Hannover	Werner-von-Siemens-Platz 1	30880 Laatzen	Tel.: (05 11) 8 77 - 24 50 Fax: (05 11) 8 77 - 21 62	ralph.bromm @siemens.com www.automation.siemens.com/mte
Siemens AG Automation and Drives RD - Ruhr Niederlassung Essen	Kruppstraße 16	45128 Essen	Tel.: (02 01) 8 16 - 29 06 Fax: (02 01) 8 16 - 30 88	thomas.heckner @siemens.com www.automation.siemens.com/rhr
Siemens AG Automation and Drives RD - Nordrhein Niederlassung Köln	Franz-Geuer-Straße 10	50823 Köln	Tel.: (02 21) 5 76 - 20 18 Fax: (02 21) 5 76 - 28 99	wilfried.negele @siemens.com www.automation.siemens.com/nrh
Siemens AG Automation and Drives RD - Rhein-Main Niederlassung Mannheim	Dynamostraße 4	68165 Mannheim	Tel.: (06 21) 4 56 - 22 21 Fax: (06 21) 4 56 - 27 47	weiss.joachim @siemens.com www.automation.siemens.com/rhm
Siemens AG Automation and Drives RD - Südwest Niederlassung Stuttgart	Weissacher Straße 11	70499 Stuttgart	Tel.: (07 11) 1 37 - 23 87 Fax: (07 11) 1 37 - 39 40	josef.karle @siemens.com www.automation.siemens.com/sdw
Siemens AG Automation and Drives RD - Nordbayern Niederlassung Nürnberg	Von-der-Tann-Straße 30	90439 Nürnberg	Tel.: (09 11) 6 54 - 21 73 Fax: (09 11) 6 54 - 162173	singer.michael @siemens.com www.automation.siemens.com/nby
Siemens AG Automation and Drives RD - Südbayern Niederlassung München	Richard-Strauss-Straße 76	81679 München	Tel.: (0 89) 92 21 - 36 32 Fax: (0 89) 92 21 - 30 89	jonas.tekampe @siemens.com www.automation.siemens.com/sby

Werke

A. Friedr. Flender AG Werk Friedrichsfeld	Am Industriepark 2	46562 Voerde	Tel.: (0 28 71) 92 - 0 Fax: (0 28 71) 92 - 25 96	contact@flender.com www.flender.com
A. Friedr. Flender AG Werk Wesel	Brüner Landstraße 5	46485 Wesel	Tel.: (02 81) 98 81 - 0 Fax: (02 81) 98 81 - 12 40	contact@flender.com www.flender.com
Flender Industriegetriebe GmbH	Thierbacher Straße 24	09322 Penig	Tel.: (03 73 81) 6 - 0 Fax: (03 73 81) 8 02 86	ute.tappert@siemens.com www.flender.com
A. Friedr. Flender AG Kupplungswerk Mussum	Industriepark Bocholt Schlavenhorst 100	46395 Bocholt	Tel.: (0 28 71) 92 - 21 85 Fax: (0 28 71) 92 - 25 79	couplings@flender.com www.flender.com
Flender Guss GmbH	Obere Hauptstraße 228 - 230	09228 Chemnitz/ Wittgensdorf	Tel.: (0 37 22) 64 - 0 Fax: (0 37 22) 9 41 38	flender-guss.aud @siemens.com www.flender-guss.de
Winergy AG	Am Industriepark 2 46562 Voerde	Postfach 201160 46553 Voerde	Tel.: (0 28 71) 92 - 4 Fax: (0 28 71) 92 - 24 87	info@winergy-ag.com www.winergy-ag.com
Siemens Geared Motors GmbH	Bahnhofstraße 40 - 44 72072 Tübingen	Postfach 1709 72007 Tübingen	Tel.: (0 70 71) 7 07 - 0 Fax: (0 70 71) 7 07 - 4 00	sales-sgm.aud @siemens.com www.siemens.de/ getriebemotoren
Loher GmbH	Hans-Loher-Straße 32 94099 Ruhstorf	Postfach 1164 94095 Ruhstorf	Tel.: (0 85 31) 39 - 0 Fax: (0 85 31) 39 - 4 37	info@loher.de www.loher.de

Service International

A. Friedr. Flender AG Service International	Werk Friedrichsfeld Am Industriepark 2 46562 Voerde	Postfach 201160 46553 Voerde	Tel.: (0 28 71) 92 - 24 02 Fax: (0 28 71) 92 - 15 17	werner.vahlenkamp @siemens.com www.flender-service.com
	24h Service Hotline		+49 (0) 17 22 81 01 00	
	Werk Herne Südstraße 111 44625 Herne	Postfach 101720 44607 Herne	Tel.: (0 23 23) 9 40 - 1 01 Fax: (0 23 23) 9 40 - 3 33	infos@flender-service.com www.flender-service.com
	Werk Penig Thierbacher Straße 24 09322 Penig	Postfach 44/45 09320 Penig	Tel.: (03 73 81) 61 - 5 20 Fax: (03 73 81) 61 - 4 88	reinhard.mehner @siemens.com www.flender-service.com

Addresses - International

(2008-05-08)

EUROPE					
AUSTRIA	Siemens AG Österreich Automation & Drives	Postfach 83 Siemensstrasse 90-92	1211 Wien 1210 Wien	Phone: +43 (0) 5 - 17 07-0 Fax: +43 (0) 5 - 17 07 5 50 20	josef.wistrcil@siemens.com www.siemens.at/ad
BELGIUM & LUXEMBOURG	Siemens n.v./s.a. Energy-Industry-Transport Automation & Drives IPS	Gebäude: 43/+2 Guido Gezellestraat 121	1654 Huizingen Beersel	Phone: +32 (0) 2 - 5 36 99 17 Fax: +32 (0) 2 - 5 36 22 06	mechanical_drives.be @siemens.com www.siemens.be/drives
BULGARIA	Auto - Profi N GmbH	102, Bulgaria Boul. Business Center "Bellissimo" Office 48	1680 Sofia	Phone: +359 (0) 2 - 8 54 94 40 Fax: +359 (0) 2 - 8 54 94 46	flender@auto-profi.com
CROATIA/SLOVENIA BOSNIA- HERZEGOVINA	HUM - Naklada d.o.o.	Mandroviceva 3 a	10000 Zagreb	Phone: +385 (0) 1 - 2 30 60 25 Fax: +385 (0) 1 - 2 30 60 24	bozo.markota@zg.t-com.hr
CZECH REPUBLIC	Siemens s.r.o. Automation & Drives	Fibichova 218	27601 Melnik	Phone: +420 315 - 62 12 20 Fax: +420 315 - 62 12 22	petr.pumprla@siemens.com
DENMARK	Siemens A/S	Borupvang 3	2750 Ballerup	Phone: +45 - 44 77 44 77 Fax: +45 - 44 77 40 19	ad-ekspedition.dk @siemens.com www.siemens.dk/gear
ESTHONIA	AS Siemens Automation & Drives	Pärnu mnt. 139 C	11317 Tallinn	Phone: +372 - 6 30 88 41 Fax: +372 - 6 30 88 89	artur.jakimenko@siemens.com www.siemens.ee
FINLAND	Siemens Osakeyhtiö	P.O. Box 60 Majurinkatu 6	02601 Espoo 02600 Espoo	Phone: +358 (0) 10 - 5 11 51 51 Fax: +358 (0) 10 - 5 11 39 99	admyynti.fi@siemens.com www.siemens.fi/ad
FRANCE	Siemens S.A.S. Automation & Drives	3, rue Jean Monnet - B.P. 5	78996 Elancourt Cedex	Phone: +33 (0) 1 - 30 66 39 00 Fax: +33 (0) 1 - 30 66 32 67	contact.flender.fr@siemens.com www.siemens.fr
	Siemens S.A.S. Automation & Drives	Sales Office Parc Inopolis, Route de Vourles	69230 Saint Genis Laval	Phone: +33 (0) 4 - 72 83 95 20 Fax: +33 (0) 4 - 72 83 95 39	contact.flender.fr@siemens.com www.siemens.fr
FRANCE	Flender-Graffenstaden SA	1, rue du Vieux Moulin	67400 Illkirch - Graffenstaden	Phone: +33 (0) 3 - 88 67 60 00 Fax: +33 (0) 3 - 88 67 06 17	flencomm@flender-graff.com www.siemens.fr
GREECE ALBANIA MACEDONIA	Siemens A.E. Automation & Drives	P.O. Box 61011 Artemidos 8	15110 Amaroussio Athens 15125 Amaroussio Athens	Phone: +30 210 - 6 86 43 94 Fax: +30 210 - 6 86 43 88	stefanos.stamidis @siemens.com www.siemens.gr
HUNGARY	Siemens Zrt. Automation & Drives	Gizella út 51-57	1143 Budapest	Phone: +36 1 - 4 71 19 65 Fax: +36 1 - 4 71 17 04	laszlo.jambor@siemens.com www.siemens.hu/ad
IRELAND	Siemens Ltd. Automation & Drives	Leeson Close	Dublin 2	Phone: +353 (0) 1 - 2 16 24 00 Fax: +353 (0) 1 - 2 16 24 99	domhnall.carroll@siemens.com
ITALY	Siemens S.p.A. Automation & Drives	Viale Piero e Alberto Pirelli, 10	20126 Milano	Phone: +39 (0) 02 - 24 31 Fax: +39 (0) 02 - 24 36 22 12	angelo.bigoni@siemens.com www.siemens.it/ad
LATVIA	Siemens SIA Automation & Drives	Lidostas "Riga" teritorija Marupes pagasts, Rigas rajons	1053 Riga	Phone: +371 - 67 01 55 00 Fax: +371 - 67 01 55 01	siemens.lv@siemens.com www.siemens.lv
LITHUANIA	UAB Siemens Automation & Drives	J. Jasinskio str. 16c	01112 Vilnius	Phone: +370 5 - 2 39 15 00 Fax: +370 5 - 2 39 15 01	sergejus.gaizauskas @siemens.com www.siemens.lt
THE NETHERLANDS	Siemens Nederland N.V. Industry - Motion Control & Drives	Lokatie K2.3 Prinses Beatrixlaan 800 Postbus 16068	2595 BN Den Haag 2500 BB Den Haag	Phone: +31 (0) 70 - 3 33 69 74 Fax: +31 (0) 70 - 3 33 12 12	salesflender.nl@siemens.com www.siemens.nl
THE NETHERLANDS	Bruinhof B.V.	Boterdiep 37 Postbus 9607	3077 AW Rotterdam 3007 AP Rotterdam	Phone: +31 (0) 10 - 4 97 08 08 Fax: +31 (0) 10 - 4 82 43 50	info@bruinhof.nl www.bruinhof.nl
NORWAY	Siemens AS Division Automation & Drives	Østre Aker vei 90 Postboks 1	0596 Oslo 0613 Oslo	Phone: +47 - 22 63 30 00 Fax: +47 - 22 63 31 05	adinfo@siemens.no www.siemens.no/ad
POLAND	Siemens Sp. z o.o. Automation & Drives	Ul. Gawronów 22	40-527 Katowice	Phone: +48 (0) 32 - 2 08 42 35 Fax: +48 (0) 32 - 2 08 43 39	marcin.walter@siemens.com www.siemens.pl/flender
PORTUGAL	Siemens, S.A. Automation & Drives	Rua Irmãos Siemens, 1	2720-093 Amadora	Phone: +351 (0) 21 - 4 17 83 87 Fax: +351 (0) 21 - 4 17 80 50	silva.amaral@siemens.com www.siemens.pt/ad
ROMANIA	CN Industrial Group SRL	Str. Vatra Luminoasa 108 Sector 2	021919 Bucuresti	Phone: +40 (0) 21 - 2 52 98 61 Fax: +40 (0) 21 - 2 52 98 60	office@flender.ro office@inacn.ro www.inacn.ro
RUSSIA	A. Friedr. Flender AG Akkreditierte Vertretung	Tjuschina 4-6	191119 St. Petersburg	Phone: +7 (0) 8 12 - 3 20 90 34 Fax: +7 (0) 8 12 - 3 20 90 82	elena.kocheva@siemens.com www.automation-drives.ru
SERBIA- MONTENEGRO	G.P.Inzenjering d.o.o.	Bulevar AVNOJ-a 87/9	11070 Novi Beograd	Phone: +381 (0) 11 - 3 01 78 67 Fax: +381 (0) 11 - 3 11 67 91	flender@eunet.yu gping@eunet.yu
SLOVAKIA	DriveTech s.r.o.	Vajanského 49, P.O. Box 286	08001 Presov	Phone: +421 (0) 9 03 64 60 44 Fax: +421 (0) 51 - 7 70 32 67	micenko.flender@nextra.sk
SPAIN	Siemens, S.A. División Productos y Sistemas Industriales PS1	Ronda de Europa, 5	28760 Tres Cantos Madrid	Phone: +34 (0) 91 - 5 14 80 00 Fax: +34 (0) 91 - 5 14 70 32	ulf.holtkamp@siemens.com www.siemens.es
SWEDEN	Siemens AB	Östergårdsgatan 2-4 Box 14153	43153 Mölndal 40020 Göteborg	Phone: +46 (0) 31 - 7 76 86 00 Fax: +46 (0) 31 - 7 76 86 76	kundcenter.ad.se @siemens.com www.siemens.se/flender
SWITZERLAND	Siemens Schweiz AG Automation & Drives, Motion Control	Freilagerstrasse 28	8047 Zürich	Phone: +41 (0) 8 48 82 28 44 Fax: +41 (0) 8 48 82 28 55	adassistance.ch @siemens.com www.siemens.ch/ad
TURKEY	Siemens Sanayi ve Ticaret A.S. Automation & Drives	Esentepe mahallesi Yakacik Caddesi no. 111	34870 Kartal Istanbul	Phone: +90 (0) 2 16 - 4 59 24 67 Fax: +90 (0) 2 16 - 4 59 32 44	mehmet.kocaoglu @siemens.com
UKRAINE	Siemens Ukraine Automation & Drives	Predslavinska Str., 11-13	03150 Kiev	Phone: +380 44 - 2 01 24 26 Fax: +380 44 - 2 01 24 66	drives.ua@siemens.com www.siemens.ua/ad
UNITED KINGDOM	Siemens plc Automation & Drives	Thornbury Works, Leeds Road	Bradford West Yorkshire BD3 7EB	Phone: +44 (0) 12 74 - 65 77 00 Fax: +44 (0) 12 74 - 66 98 36	sales-mechanicaldrives.ad.uk @siemens.com www.siemens.co.uk

FLENDER

AFRICA					
ALGERIA / TUNESIA MOROCCO	Siemens S.A.S. Automation & Drives	3, rue Jean Monnet - B.P.5	78996 Elancourt Cedex	Phone: +33 (0) 1 - 30 66 39 00 Fax: +33 (0) 1 - 30 66 35 13	contact.flender.fr@siemens.com www.siemens.fr
EGYPT	Siemens Limited	55, El Nakhil and El Aenab Street	Mohandessin, Cairo	Phone: +20 (0) 2 - 3 33 36 74 Fax: +20 (0) 2 - 3 33 36 07	hany.loka@siemens.com www.siemens.com.eg
SOUTH AFRICA	Siemens Limited	Cnr. Furnace St. & Quality Rd. P.O. Box 131	Isando - Johannesburg Isando 1600	Phone: +27 (0) 11 - 5 71 20 00 Fax: +27 (0) 11 - 3 92 24 34	dorothy.coetzee@siemens.com
	Siemens Limited	Sales Offices Unit 3 Marconi Park, 9 Marconi Crescent, Montague Gardens P.O. Box 37 291	Cape Town Chempet 7442	Phone: +27 (0) 21 - 5 51 50 03 Fax: +27 (0) 21 - 5 52 38 24	dorothy.coetzee@siemens.com
	Siemens Limited	Unit 3 Goshawk Park Falcon Industrial Estate P.O. Box 1608	New Germany - Durban New Germany 3620	Phone: +27 (0) 31 - 7 05 38 92 Fax: +27 (0) 31 - 7 05 38 72	dorothy.coetzee@siemens.com
	Siemens Limited	9 Industrial Crescent, Ext. 25 P.O. Box 17 609	Witbank Witbank 1035	Phone: +27 (0) 13 - 6 92 34 38 Fax: +27 (0) 13 - 6 92 34 52	dorothy.coetzee@siemens.com
	Siemens Limited	Unit 14 King Fisher Park, Alton Chr. Ceramic Curve & Alumina Allee, P.O. Box 101995	Richards Bay Meerensee 3901	Phone: +27 (0) 35 - 7 51 15 63 Fax: +27 (0) 35 - 7 51 15 64	dorothy.coetzee@siemens.com
AMERICA					
ARGENTINA	Siemens S.A.	Calle 122 No. 4785 (ex Gral. Roca) Ruta 8 km 18	Prov. de Buenos Aires	Phone: +54 (0) 11 - 47 38 71 00 Fax: +54 (0) 11 - 47 38 72 71	marcos.cardaci@siemens.com
BRASIL	Flender Brasil Ltda.	Rua Quatorze, 60 Cidade Industrial	CEP: 32211 - 970 Contagem - MG	Phone: +55 (0) 31 - 33 69 21 00 Fax: +55 (0) 31 - 33 69 21 66	vendas@flenderbrasil.com
	Flender Brasil Ltda.	Sales Offices Rua James Watt, 142 - conj. 142 - Brooklin Novo	CEP: 04576 - 050 São Paulo - SP	Phone: +55 (0) 11 - 55 05 99 33 Fax: +55 (0) 11 - 55 05 30 10	flesao@uol.com.br
	Flender Brasil Ltda.	Rua Campos Salles, 1095 sala 04 - Centro	CEP: 14015 - 110 Ribeirão Preto - SP	Phone: +55 (0) 16 - 6 35 15 90 Fax: +55 (0) 16 - 6 35 11 05	flender.ribpreto@uol.com.br
	Flender Brasil Ltda.	Rua Da Mitra - quadra 30 sala 207 - Edifício Cristal - lote 16	CEP: 65075 - 770 São Luis - MA	Phone: +55 (0) 98 - 32 25 84 92 Fax: +55 (0) 98 - 32 25 84 93	flenderslz@uol.com.br
	Flender Brasil Ltda.	Rua Padre Anchieta, 1691 - conj. 1110 - Bairro Bigorriho	CEP: 80730 - 000 Curitiba - PR	Phone: +55 (0) 41 - 3 36 28 49 Fax: +55 (0) 41 - 99 64 24 04	quality.engineer@bol.com.br
CANADA	Siemens Canada Ltd. Automation & Drives	215 Shields Court, Units 4-6	Markham Ontario L3R 8V2	Phone: +1 (0) 9 05 - 3 05 10 21 Fax: +1 (0) 9 05 - 3 05 10 23	bershu.nkwawir@siemens.com www.siemens.ca
CHILE	Siemens S.A. Automation & Drives	Av. Providencia 1760, Piso 11 Edifício Palladio	Santiago de Chile	Phone: +56 (0) 2 - 4 77 71 00 Fax: +56 (0) 2 - 4 77 10 58	r.wagner@siemens.com www.siemens.cl
COLOMBIA	A.G.P. Representaciones Ltda.	Flender Liaison Office Colombia Av Boyaca No. 23 A 50 Bodega UA 7-1	Bogotá	Phone: +57 (0) 1 - 5 70 63 53 Fax: +57 (0) 1 - 5 70 73 35	aguerrero@agp.com.co www.agp.com.co
MEXICO	Siemens S.A. de C.V. Automation & Drives	Poniente 116 No. 590 Col. Industrial Vallejo	02300 México, D.F.	Phone: +52 (0) 55 - 53 28 20 00 Fax: +52 (0) 55 - 53 28 21 92	rafael.galan@siemens.com
	Siemens S.A. de C.V. Automation & Drives	Libramiento Arco Vial Km. 4.2 Santa Catarina	C.P. 66350 Nuevo León	Phone: +52 (0) 81 - 81 24 41 00 Fax: +52 (0) 81 - 81 24 41 12	hector.lugo@siemens.com
PERU	Siemens S.A.C. Automation & Control	Av. Domingo Orué 971 Surquillo	Lima 34	Phone: +51 (0) 1 - 2 15 00 30 Fax: +51 (0) 1 - 4 41 40 47	isaac.maizel@siemens.com
USA	Siemens Energy & Automation, Inc. Power Conversion Division	950 Tollgate Road	Elgin, IL. 60123	Phone: +1 (0) 8 47 - 9 31 19 90 Fax: +1 (0) 8 47 - 9 31 07 11	conny.kramp@siemens.com www.siemens.com
	Siemens Energy & Automation	Service Location 4234 Foster Ave.	Bakersfield CA. 93308 - 4559	Phone: +1 (0) 6 61 - 3 25 44 78 Fax: +1 (0) 6 61 - 3 25 44 70	karen.peterson@siemens.com www.siemens.com
VENEZUELA	F. H. Transmisiones S.A.	Urbanización Buena Vista Calle Johan Schafer o Segunda Calle, Municipio Sucre	Petare, Caracas	Phone: +58 (0) 2 - 12 21 52 61 Fax: +58 (0) 2 - 12 21 18 38	ventas@fhtransmisiones.com www.fhtransmisiones.com
ASIA					
IRAQ / JORDAN KUWAIT / LEBANON LYBIA	Please refer to: A. Friedr. Flender AG	Alfred-Flender Straße 77	46395 Bocholt	Phone: +49 (0) 28 71 - 92 19 22 Fax: +49 (0) 28 71 - 92 22 50	suha.elbil@siemens.com
BANGLADESH SRI LANKA	Please refer to: Flender Limited	No. 2 St. George's Gate Road 5 th Floor	Hastings Kolkata - 700022	Phone: +91 (0) 33 - 2 23 05 45 Fax: +91 (0) 33 - 2 23 18 57	flender@flenderindia.com
PEOPLE'S REPUBLIC OF CHINA	Siemens Mechanical Drive Systems (Tianjin) Co., Ltd.	ShuangHu Rd. - Shuangchen Rd. West, Beichen Economic Development Area (BEDA)	Tianjin 300400	Phone: +86 (0) 22 - 26 98 2 Fax: +86 (0) 22 - 26 97 20 61	www.ad.siemens.com.cn
	Siemens Ltd. Automation & Drives	Beijing Sales Office 6 th Floor, Wang Jing Tower B 9, Wangjing Zhonghuan Nan Lu Chaoyang District	Beijing 100102	Phone: +86 (0) 10 - 64 76 45 05 Fax: +86 (0) 10 - 64 76 48 78	www.ad.siemens.com.cn

FLENDER

INDIA	Flender Limited	No. 2 St. George's Gate Road 5 th Floor	Hastings Kolkata - 700 022	Phone: +91 (0) 33 - 22 23 05 45 Fax: +91 (0) 33 - 22 23 18 57	flender@flenderindia.com
	Flender Limited	Industrial Growth Centre Rakhajungle	Nimpura Kharagpur - 721 302	Phone: +91 (0) 3222 - 23 33 07 Fax: +91 (0) 3222 - 23 33 64	works@flenderindia.com
	Flender Limited	Eastern Regional Sales Office No. 2 St. George's Gate Road 5 th Floor	Hastings Kolkata - 700 022	Phone: +91 (0) 33 - 22 23 05 45 Fax: +91 (0) 33 - 22 23 08 30	ero@flenderindia.com
	Flender Limited C/o Siemens Limited Automation & Drives Division	Thane Belapur Road	Kalwa - Thane - 400 601 Maharashtra	Phone: +91 (0) 22 - 27 60 00 01 Fax: +91 (0) 22 - 27 62 39 23	wro@flenderindia.com
	Flender Limited	Southern Regional Sales Office No. 4 Mahatma Gandhi Road (VI Floor)	Nungambakkam Chennai - 600 034	Phone: +91 (0) 44 - 28 33 42 90 Fax: +91 (0) 44 - 28 33 31 31	sro@flenderindia.com
	Flender Limited	Northern Regional Sales Office 302 Bhikaji Cama Bhawan 11 Bhikaji Cama Palace	New Delhi - 110 066	Phone: +91 (0) 11 - 41 85 96 56 Fax: +91 (0) 11 - 41 85 96 59	nro@flenderindia.com
INDONESIA	P.T. Siemens Indonesia Automation & Drives	Jalan Jendral Ahmad Yani Kav. B 67 - 68	Pulomas Jakarta 13210	Phone: +62 (0) 21 - 24 55 55 66 Fax: +62 (0) 21 - 4 71 50 63	bob.wall@siemens.com
IRAN	Siemens Sherkate Sahami Khas Automation & Control Group Automation & Drives	No. 32, Taleghani Ave. P.O. Box 15 875 - 4773	Tehran 15936	Phone: +98 (0) 21 - 66 14 44 44 Fax: +98 (0) 21 - 88 94 23 88	houshang.assadzadeh @siemens.com
ISRAEL	Siemens Israel Ltd. Automation & Drives	14 Hamelacha Street	48091 Rosh Ha'ayin	Phone: +972 (0) 3 - 9 15 19 65 Fax: +972 (0) 3 - 9 15 15 11	tzvi.kobielsky@siemens.com
JAPAN	Siemens K.K. Automation & Drives	Takanawa Park Tower 17F 3 - 20 - 14 Higashi Gotanda Shinagawa - ku	141 - 8641 Tokyo	Phone: +81 (0) 3 - 54 23 87 05 Fax: +81 (0) 3 - 54 23 87 32	contact_flender_products.skk @siemens.com www.siemens.co.jp/ad
KAZAKHSTAN	OOO Siemens Automation & Drives MD	Wolynsky pereulok, 3, liter A	191 186 St. Petersburg	Phone: +7 (0) 8 12 - 3 29 85 30 Fax: +7 (0) 8 12 - 3 24 82 81	elena.kocheva@siemens.com www.automation-drives.ru
KOREA	Siemens Ltd. Automation & Drives	10th Floor, Asia Tower Building 726, Yeoksam-dong Kangnam-gu	Seoul 135 - 719	Phone: +82 (0) - 8 05 01 30 00 Fax: +82 (0) 2 - 34 50 71 57	marketing.ad-kr@siemens.com www.siemens.seoul.kr
MALAYSIA	Siemens Malaysia Sdn. Bhd. Automation & Drives	Level 1 Reception, CP Tower No. 11, Jalan 16/11 Pusat Dagang Seksyen 16	46350 Petaling Jaya Selangor Darul Ehsan	Phone: +60 (0) 3 - 79 52 51 74 Fax: +60 (0) 3 - 79 57 31 80	lep-ming.soh@siemens.com www.siemens.com.my/ automation
PAKISTAN	Siemens Pakistan Engineering Co. Ltd. STP	B-72, Estate Avenue, S.I.T.E.	Karachi 75700	Phone: +92 (0) 21 - 2 57 49 10 Fax: +92 (0) 21 - 2 57 62 00	imran.mustafa@siemens.com
PHILIPPINES	Siemens Inc. Automation & Drives	Door No. 3, 2/F Carlos Perez Building A.C. Cortes Avenue, Ibabao	Mandaue City 6014 Cebu	Phone: +63 (0) 2 - 8 14 90 75 Fax: +63 (0) 32 - 3 43 86 41	jun.tumaming@siemens.com
SAUDI ARABIA	South Gulf Sands Est.	Bandaria Area, Dohan Bldg. Flat 3/1, P.O. Box 32 150	Al-Khobar 31952	Phone: +966 (0) 3 - 8 87 53 32 Fax: +966 (0) 3 - 8 87 53 31	adelameen@nesma.net.sa
SINGAPORE	Siemens Pte. Ltd. Automation & Drives	The Siemens Center 60 MacPherson Road	Singapore 348615	Phone: +65 (0) - 64 90 65 38 Fax: +65 (0) - 64 90 89 93	soothong.tan@siemens.com www.siemens.com.sg/ad
SYRIA	Misrabi Co & Trading	Mezzeh Autostrade Transportation Building 4/A, 5th Floor P.O. Box 12450	Damascus	Phone: +963 (0) 11 - 6 11 67 94 Fax: +963 (0) 11 - 6 11 09 08	ismael.misrabi@gmx.net
TAIWAN	Siemens Limited Automation & Drives	8F, No. 3, Yuan Qu St., Nan Gang District	Taipei 11503	Phone: +886 (0) 2 - 26 52 88 88 Fax: +886 (0) 2 - 26 52 88 14	stella.su@siemens.com www.siemens.com.tw/ automation
THAILAND	Siemens Limited Automation & Drives	Charn Issara Tower II 23th Floor 2922/283 New Petchburi Road	Bangkapi, Huaykwang Bangkok 10310	Phone: +66 (0) 27 - 15 41 41 Fax: +66 (0) 27 - 15 48 41	ADHelpline.TH@siemens.com www.siemens.co.th/a&d
UNITED ARAB EMIRATES / BAHRAIN / OMAN / QATAR / YEMEN	Siemens LLC Automation & Drives	Dubai Internet City, Siemens Building, Level 2B P.O. Box 2154	Dubai	Phone: +971 (0) 4 - 3 66 06 59 Fax: +971 (0) 4 - 3 66 00 19	hesham.khalid @siemens.com
VIETNAM	Siemens AG Representation Vietnam	The Landmark Building 2nd Floor 5B Ton Duc Thang St., District 1	Ho Chi Minh City	Phone: +84 (0) 8 - 8 25 19 00 Fax: +84 (0) 8 - 8 25 15 80	eddie.chung@siemens.com ha-phuong.thu@siemens.com
AUSTRALIA					
	Siemens Ltd. IAC - MD	9 Nello Place, P.O.Box 6047	Wetherill Park NSW 2164, Sydney	Phone: +61 (0) 2 - 96 16 67 00 Fax: +61 (0) 2 - 96 16 67 01	jillian.lindsay@siemens.com www.siemens.com.au
	Siemens Ltd. IAC - MD	885 Mountain Highway	Bayswater VIC 3153, Melbourne	Phone: +61 (0) 3 - 97 21 20 00 Fax: +61 (0) 3 - 97 21 76 50	jillian.lindsay@siemens.com www.siemens.com.au
	Siemens Ltd. IAC - MD	P.O. Box 235 Level 1, Building 2, Citilink Busi- ness Centre, 153 Campbell Str.	Royal Brisbane Hospital, QLD 4029 Bowen Hills QLD 4006, Brisbane	Phone: +61 (0) 7 - 33 32 83 00 Fax: +61 (0) 7 - 33 32 83 01	jillian.lindsay@siemens.com www.siemens.com.au
	Siemens Ltd. IAC - MD	43 King Edward Road	Osborne Park WA 6017, Perth	Phone: +61 (0) 8 - 92 41 80 00 Fax: +61 (0) 8 - 92 41 44 02	jillian.lindsay@siemens.com www.siemens.com.au
NEW ZEALAND	Siemens Ltd. IAC - MD	9 Nello Place, P.O.Box 6047	Wetherill Park NSW 2164, Sydney	Phone: +61 (0) 2 - 96 16 67 00 Fax: +61 (0) 2 - 96 16 67 01	jillian.lindsay@siemens.com www.siemens.com.au

12. Declaration by the manufacturer

Declaration by the manufacturer

in accordance with EC Engineering Directive 98/37/EC, Appendix II B

We hereby declare that the components described in these Operating Instructions:

Combined Gear Unit
Radial piston motor with planetary gear unit types
PEA, PEB, PEF Sizes 112 to 335
PZA, PZB, PZF Sizes 170 to 375

zum Einbau in eine Maschine bestimmt sind, und daß ihre Inbetriebnahme solange untersagt ist, bis
are intended for incorporation in a machine, and that it is prohibited to put them into service before
verifying that the machine into which they are incorporated complies with the EC Directive (original
edition 98/37/EC including any subsequent amendments thereto).

This Declaration by the Manufacturer takes into account all the unified standards (inasmuch as they
apply to our products) published by the European Commission in the Official Journal of the European
Community.



Bocholt, 2007-10-09

Signature (Director Engineering HDE)