

Operating Instructions

N – R 432 en 06.00

for surface-cooled (TEFC),
internally cooled (with air-to-air heat exchanger) and
water-cooled three-phase generators
with slipping rotor

for low voltage, with antifriction bearings

AFSA-...

AFWA-...

JFRA-...

Table of contents

	Page
1. Safety and commissioning instructions	2
2. Description	5
3. Transport	7
4. Installation and commissioning	8
5. Maintenance	16
6. Additional equipment	23
7. Spare parts	24
Appendix A	25

Safety and commissioning instructions

1 Safety and commissioning instructions

1.1 General

Low voltage motors have dangerous, **live** and **rotating** parts, and probably **hot** surfaces. All work for transport, connection, commissioning and maintenance is to be made by **qualified, responsible** specialists (prEN50110–1/VDE 0105; IEC 364 must be observed). An inadequate behaviour can cause severe **damages to persons and property**.

1.2 Specified use

These low voltage motors are only meant for use in **industrial** plants. They are in accordance with the harmonized standards of the series **EN 60 034 (VDE 0530)**. Their use in **hazardous areas** is prohibited.

Air-cooled types are suitable for ambient temperatures from **–20 °C (68 °F) to +40 °C (104 °F)** as well as altitudes **≤ 1000 m** above mean sea level. It is **imperative** to observe differing data on the rating plate. Conditions at the site of application must comply with **all** indicated data on the rating plate.

Low voltage motors are **components** to be installed into machines in accordance with Directive 89/392/EEC. **Commissioning** is not allowed as long as the conformity of the end product with this directive is not established (also observe EN 60 204–1).

1.3 Transport, storage

The carrier is immediately to be informed on **damages** found upon delivery; **commissioning must not be admitted**, if required. Screwed-in lifting eyes are to be tightened. They are only suitable for the weight of the low voltage motors, **no** additional loads are allowed to be attached. If required, sufficiently dimensioned means of transport (e.g. rope guides) are to be used. Prior to commissioning the **transport locking devices** are to be **removed**. Reuse for further transports. For storage of low voltage motors, take care of a **dry, dustfree** and **low-vibration** ($v_{\text{eff}} \leq 0,2 \text{ mm/s}$) ambience (bearing damages with motor at standstill).

Before commissioning the insulation resistance is to be measured. If the limit values (see 4.2) are exceeded the winding must be dried. "Observe Storage instructions".

1.4 Installation

Take care of an even ground, suitable fastening of feet or flange and an exact alignment for direct coupling. Avoid that structure-dependent natural frequencies occur within the rotary frequency and the double mains frequency. Turn rotor **by hand**, listen to abnormal frictioning noises. **Check direction of rotation** before coupling (see paragraph "Electrical Connection").

Pulleys and couplings are **only** allowed to be installed or removed with suitable devices (Heating!) and to be covered with **protection against accidental contact**. Avoid excessive belt tensions (Technical List). The **balance** of the low voltage motor is indicated on the shaft end face or on the rating plate (H = half key, F = full key). In case of a half key (H), the coupling must also be balanced with a half key. Remove any **protruding and visible** part of the key.

If required, make the necessary pipe connections. Mounting types with the shaft end facing upwards are to be provided with a cover by **the customer**, avoiding that foreign bodies fall into the fan.

Safety and commissioning instructions

Ventilation must **not be hindered** and the outgoing air – also from adjacent units – must not be directly sucked in again.

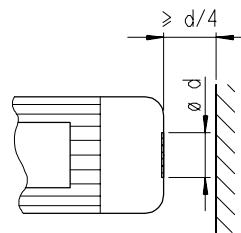

1.5 Electrical connection

All work is only allowed to be done by **qualified** personnel with the low voltage motor and driven machine at standstill, **electrically dead** and **locked against restart**. This is also applicable to auxiliary circuits (e.g. space heater).

Check de-energizing!

A non-observance of the tolerances indicated in EN 60 034-1/VDE 0530, part 1 – voltage $\pm 5\%$, frequency $\pm 2\%$, curvature, symmetry – will result in an excessive heating and is influencing the electromagnetic compatibility. Observe data on the rating plate as well as wiring diagram in the terminal box.

Observe connection and differing data on the rating plate as well as the wiring data in the terminal box.

Connection is to be made in such a way that a **durably safe**, electrical connection is maintained (no uncovered wire ends); especially provided cable end equipment is to be used. A safe **earthing** is to be made.

The minimum air gaps between uninsulated and live parts themselves and to earth must not be lower than the following values: 8 mm at $U_N \leq 550$ V, 10 mm at $U_N \leq 750$ V, 14 mm at $U_N \leq 1100$ V.

The terminal box must be **free of** foreign bodies, dirt as well as humidity. Unused cable entries and the box itself are to be sealed against **dust** and **water**. Mains supply lines must be sealed in the cable entries according to specifications. For trial operation without driving elements the key is to be secured. For motors with brake it is to be **checked** before putting into operation, if the **brake** is perfectly functioning.

1.6 Operation

Vibration severity (V_{eff}) see data sheet. In case of changes compared with normal operation – e.g. **higher temperatures, noises, vibrations** – the cause is to be found, if required, consult the manufacturer. Even for trial operation the safety devices are not allowed to be put out of function. In **case of doubt** switch off the low voltage motor.

In case of heavy dirt accumulation, the air ducts must be cleaned at regular intervals.

Bearings with regreasing devices are to be regreased with low voltage motor **running**. Risk of accidents! Pay attention to rotating parts. Observe saponification class! (see page 17) If grease drainholes are sealed with a plug, **remove these plugs** before putting into operation. Seal bores with grease. See data sheet for replacement of bearings.

1.7 Warranty

The **Warranty** is only applicable if all of these instructions for safety and putting into operation as well as the following paragraphs of the operating instructions and the directions for possible additional units are strictly observed.

Safety and commissioning instructions

Safety- and commissioning instructions must be strictly observed.

The **Warranty** requires the strict observance of these instructions for safety and commissioning as well as of the following paragraphs of the operating instructions and of the instructions for possible additional equipment.

The plant assembler is responsible for an adequate installation (e.g. separation of signal lines and power cables, shielded conductors and cables etc.)

A wide-coverage earthing is required for the shieldings.



Prevent failures and thus avoid damages to persons and property.

The person responsible for the installation has to make sure, that

- safety- and operating instructions are available and observed
- operating conditions and technical data acc. to the order are observed
- protective equipment is used
- specified maintenance work is carried out.



For inverter operation the applicable instructions for commissioning and the operating instructions for the inverter have to be observed. In addition it has to be complied with the data according to paragraph 4.4.

Description

2 Description

2.1 General construction

Mounting type acc. to DIN EN 60 034–7: see dimension drawing

Horizontal arrangement: IM B3

Cooling type acc. to DIN EN 60 034–6: see dimension drawing

IC 411 Surface cooling (TEFC)/Self-ventilation

IC 71W Water cooling

IC 611 Air-to-air heat exchanger
(internally cooled motor with mounted-on heat exchanger)

2.2 Bearings

The generators are equipped with antifriction bearings.

The bearings are grease-lubricated, have regreasing units and automatic grease quantity regulators.

2.3 Cooling

2.3.1 Surface cooling (TEFC) for the Type AFSA–...

Design for fin- or tube cooling, where an external fan takes in the cooling air through the openings in the fan cover and presses the air over the surface or through the cooling tubes of the stator housing. The heat dissipation is supported by a closed cooling air circuit inside the generator.

2.3.2 Water cooling for the Type AFWA–...

The stator housing is provided with a double casing, which for water-carrying purposes is sectionalized by coils and the cooling water is flowing through. A good heat dissipation is obtained. Moreover, there is less danger that suspended matters carried along in the water are deposited. The heat dissipation is supported by a closed cooling air circuit inside the generator.

2.3.3 Internally cooled with mounted-on air-to-air heat exchanger for the Type JFRA–...

The generators are equipped with air-to-air heat exchangers. The cooling air led through the heat exchangers is recooled in the heat exchangers and the heat loss is dissipated through the cooling medium air. An external fan presses the cooling air through the heat exchanger. Normally the heat exchanger is equipped with a forced-ventilated motor.

2.4 Generator housing

2.4.1 Construction for surface cooling (TEFC) (Type AFSA–...)

Depending on the frame size the stator frame and end shields are made of cast iron or steel. The fan cover is made of sheet steel. The stator frame surface is provided with cooling fins.

2.4.2 Construction for water-cooling (Type AFWA–...)

Stator frame and end shields are made of cast iron or steel.

The stator jacket is designed as double casing where the cooling water is led through. The frame is provided with a cooling water inlet and outlet.

2.4.3 Internal cooling with mounted-on air-to-air heat exchanger (Type JFRA–...)

Stator frame is made of steel with mounted-on heat exchanger.

End shields are made of cast iron or steel.

Description

2.5 Terminal boxes

Besides the generator main terminal box and the normally available rotor terminal box there are additional terminal boxes for monitoring devices available, if required.

As an option the rotor connection is provided directly in the slipring enclosure without rotor terminal box or integrated into the main terminal box.

2.6 Monitoring devices

Monitoring devices are only available on special order.

See paragraph 6. Evaluation is made in the control system of the wind power plant. If the admissible limit values are exceeded, the generator must be switched off.

Transport

3 Transport



For handling during transport the stator construction of the generator is equipped with lifting eyes, where the lifting hooks can be fixed.

Attach the generator only to these lifting eyes.

Several lifting eyes must always be used together.

Lifting of the generator on other parts (e.g. shaft end) is not permitted, since this might result in considerable damages.



The generator lifting eyes are only suitable for the generator weight. Additional loads attached to the generator must never be lifted using these eyes.

3.1 Check before installation

Check whether the generator has been damaged during transport. If the packing is damaged to such an extent that a generator damage is to be assumed, the packing should be removed in the presence of a representative agent of the carrier.

3.2 Bearing lock

(for generators with cylindrical roller bearings only.)

The rotor of the generator is locked in order to avoid damages to bearings caused by vibrations at standstill:



- by red marked locking screws in the bearing cap
- or by a transport locking mechanism fixed to the shaft end.

Before the generator is mounted, the locking screws must be turned back by 10 mm and locked or the transport locking device must be removed (see instruction plate on the generator). After this, it must be possible to turn the shaft by hand.

We recommend loosening of the bearing lock only after having fitted the coupling.

The transport locking mechanism **has to be** reused for further transports.

If the generator is transported without bearing lock, bearing damages are to be expected.

Installation and commissioning

4

Installation and commissioning



Surface cooling (TEFC) (Type AFSA–...)

Maximum permissible coolant temperature (room temperature on site) acc. to EN 60 034–1/ IEC 34–1 is 40 °C (104 °F) max. and a permissible altitude up to 1000 m above mean sea level (other values see rating plate).

Care must be taken that the cooling air can flow without hindrance into the air inlet openings and freely pass through the air outlet openings and cannot be directly sucked in again. Suction and outlet openings must be protected from obstructions and coarse dust.



Water cooling (Type AFWA–...)

Prior to commissioning of the water-cooled generators a proper cooling water circuit must be ensured. The water chamber of the motor has to be filled with cooling water before commissioning. At the opened vent plug water is to be filled up on the bore hole marked as cooling water inlet, until there is no air coming out on the vent plug anymore.

It must be ensured that the generator is switched on, only when the cooling water circuit is functioning and it has to be maintained until coasting of the generator after switching-off. Inlet and outlet openings are located on the generator housing.

The cooling water circuit has to be monitored. Normally the generator is provided with PTC thermistor sensors switching off the generator in case of a cooling water circuit failure. If the housing is provided vent plugs for the water chamber, these have to be vented at the first filling and later at regular intervals.

Only use clean, non-aggressive cooling water. Permissible content of suspended matters is max. 10 mg/l.

At temperatures below 0 °C an antifreeze must be added to the cooling water.



Internally cooled with mounted-on heat exchanger (Type JFRA–...)

Maximum permissible coolant temperature (room temperature on site) acc. to EN 60 034–1/ IEC 34–1 is 40 °C (104 °F) max. and a permissible altitude up to 1000 m above mean sea level (other values see rating plate).

Care must be taken that the cooling air can flow without hindrance into the air inlet openings and freely pass through the air outlet openings and cannot be directly sucked in again. Suction and outlet openings must be protected from obstructions and coarse dust.

In case of forced-ventilated generators it must be ensured that the generator is switched on, only when the forced ventilation is functioning and it has to be maintained until coasting of the generator after switching-off.

Careful mounting of the generators on an absolutely level surface in order to avoid distortions when screws are tightened. For machines which are to be coupled a careful alignment is to be observed. Elastic and insulated couplings have to be used.

Natural frequencies, increased vibrations and torsional vibrations have to be avoided.

Installation and commissioning

4.1 Mounting

Fitting of couplings.

First the shaft end should be cleaned (not with emery cloth) and then greased. Coupling should be fitted only with the aid of a fitting device. For this purpose the threaded centering hole in the shaft end can be used. Insert a threaded bolt into the threaded hole. Then place the steel washer, the diameter of which is large enough to cover the hub bore hole of the pulley or coupling. The pulley and coupling is to be pulled up onto the shaft end by means of a suitable hydraulic device.



The fitting of the coupling by means of tapping with the hammer is not permitted because of the risk of bearing damages.

**When replacing the bearings those must only be removed and reinstalled by means of suitable devices using the shaft centering. Tapping on the bearings is prohibited!
Only original spare parts must be used.**

The rotor of the generator is dynamically balanced. The balance is indicated on the shaft end face. (X = plain shaft).

Take care of the balance for installation of the driving element!

The balancing of the transmission elements to be fitted must be adapted to the rotor balancing.



The generator must only be mounted and operated according to the specified mounting type (see rating plate).



No exhalation of silicone-containing sealing compounds must be admitted to the intake air of the slipping enclosure. The same is also applicable to sealants used for mounting.

Installation and commissioning

4.2 Connection, insulation resistance



Connection must only be made by an expert and in accordance with the valid VDE safety regulations.

The relevant installation- and operating instructions as well as national and international rules have to be observed.

Observe data on the rating plate!

Compare type of current, mains voltage and frequency!

Check wiring diagram!

Connect generator motor in accordance with the wiring diagram provided in the terminal box!

The generator must be protected against excessive heating.

For earthing the generator is provided with an earthing terminal. In addition all generators have a protective conductor terminal inside the terminal boxes.



The earth brush Pos. 2*) has to be grounded – depending on the version internally or externally located – to the earthing terminal Pos. 8*) (see Figure 1, 2 and 3). Capacitive earth-fault currents and shaft voltages are discharged through the earth brush.

Both bearings are insulated.

If the rotor is connected directly to the terminal fittings Pos. 6 (Fig. 4), the externally led in cable must correspond with the thermal class of the generator.

Cable shieldings have to be grounded for a wide coverage to the earthing terminal Pos. 7 (Fig. 4) or to suitable cable glands Pos. 5 (Fig. 4).

For wear monitoring of the brushes the brush holders are equipped with optional micro-switches adjusted to a brush length (measured center brush) of 14 mm. The alarm device signalling the available length must be functional and has to be connected in the terminal box Pos. 9 (Fig. 4).

The signal has to be evaluated via an external control device or through the wind power plant control system.

The alarm device signalling the available length must give an immediate alarm and the generator is to be switched off within a certain period of time (see paragraph 5.3).

As protection against dust and humidity unused cable entries in the terminal box must have a torsionproof seal. All terminal screws and nuts have to be securely tightened to avoid excessive transition resistances.

Installation and commissioning

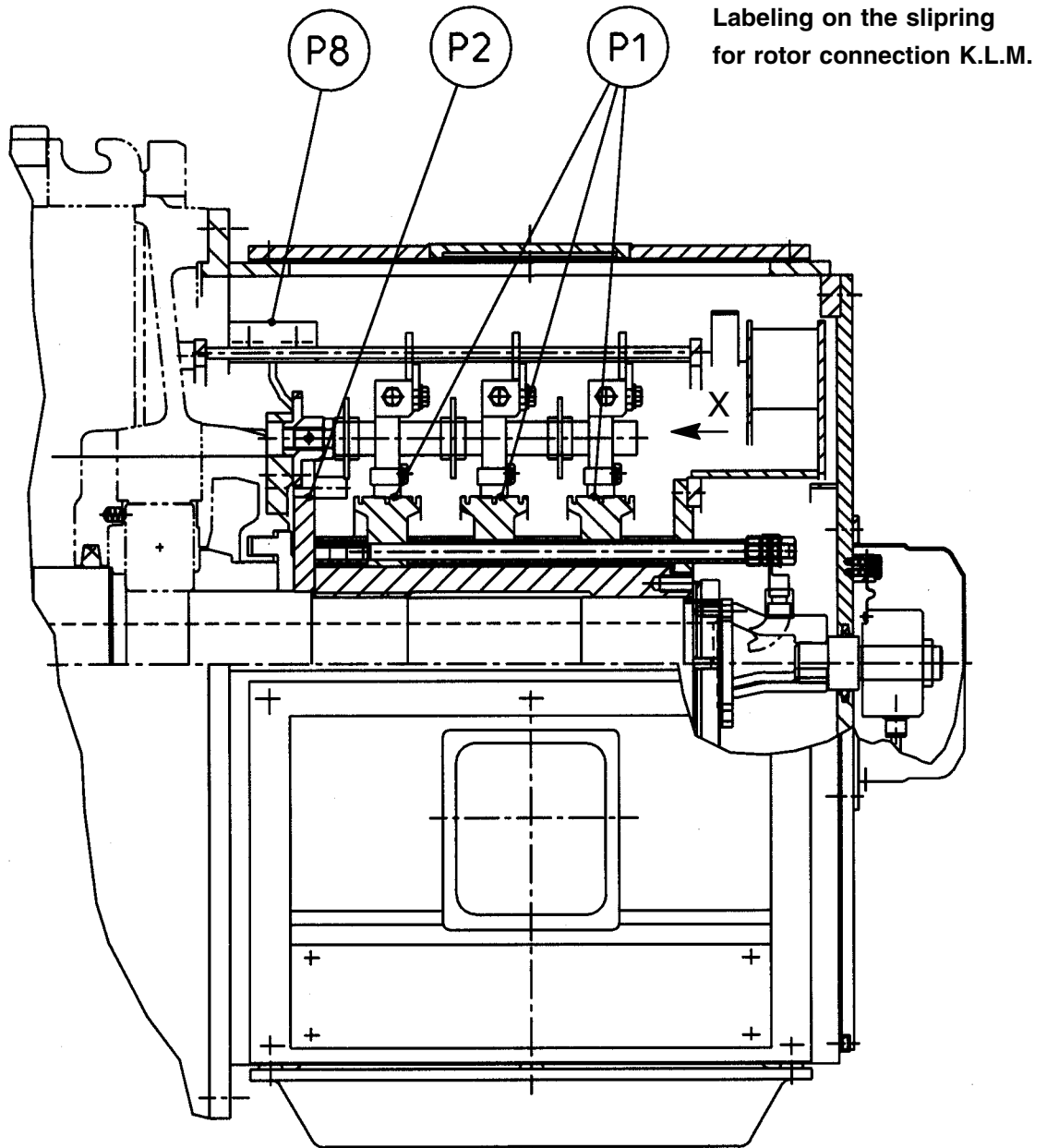

Figure 1: Slipring enclosure

Customer earthing of the slipring enclosure
is to be connected on terminal Pos. 8.

- P.1 Brush-Rotor Connection
- P.2 Brush-Earthing Shaft
- P.8 Earthing-Shaft

Installation and commissioning

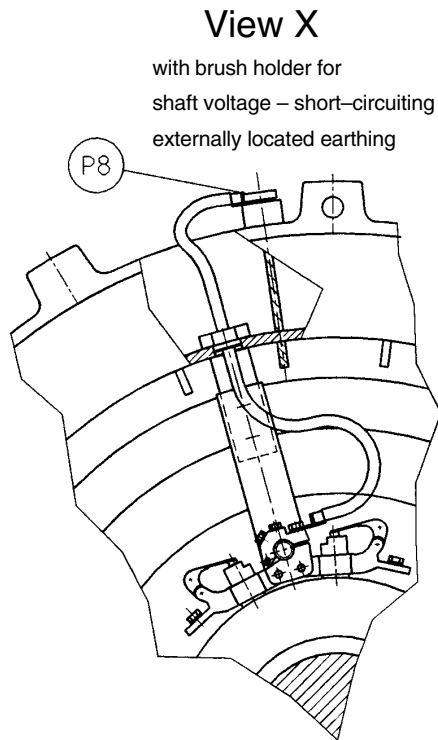

Figure 2: Earth brush

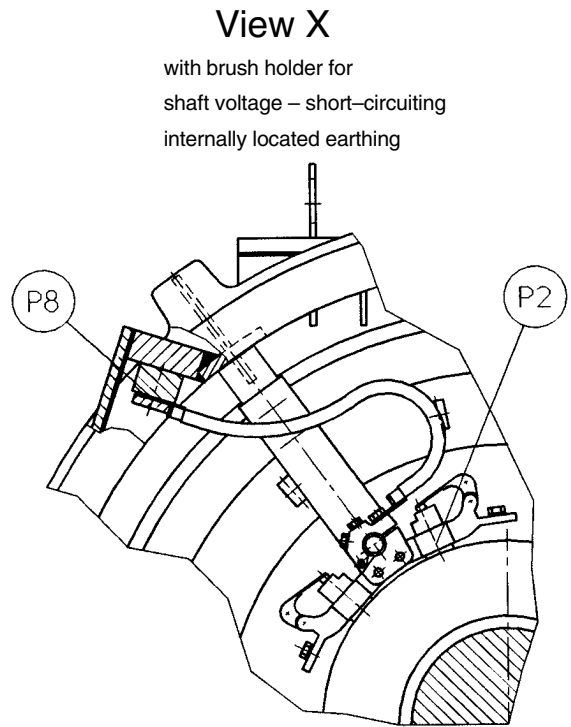

Figure 3: Earth brush

P.2 Brush–Earthing Shaft
P.8 Earthing–Shaft

Installation and commissioning

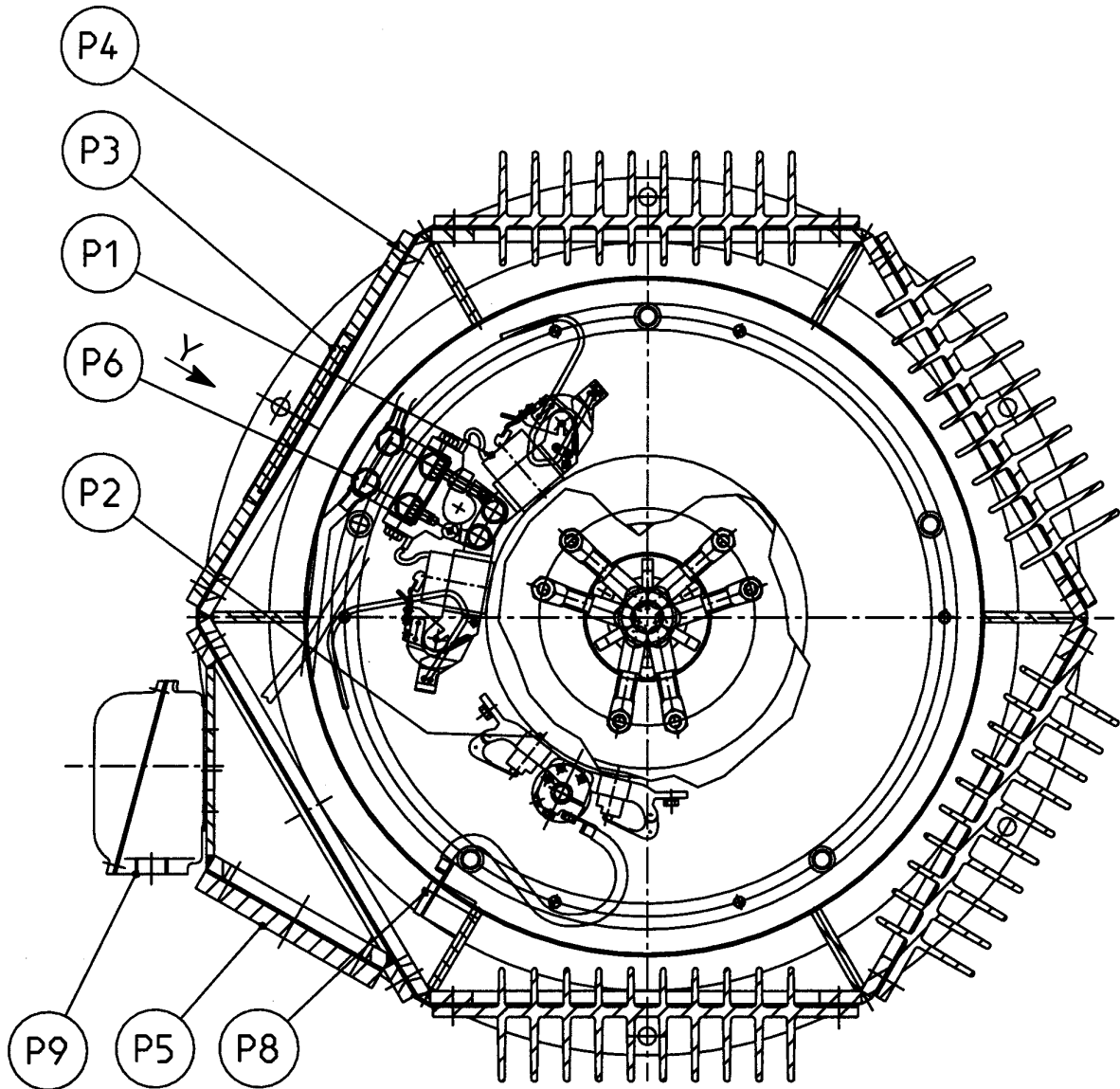
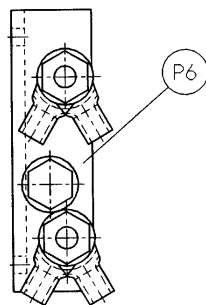

Figure 1: Slipring enclosure

View Y (Scale 1:1)



- P. 1 Brush-Rotor Connection
- P. 2 Brush-Earthing Shaft
- P. 3 Servicing Opening
- P. 4 Screws Servicing Opening
- P. 5 Cable Entry-Rotor
- P. 6 Terminal Fitting-Rotor
- P. 7 Earthing-Shielding
- P. 8 Earthing-Shaft
- P. 9 Terminal Box for Alarm Device Signalling the Available Length

Installation and commissioning

After longer storage periods or standstill the insulation resistance of the winding must be measured phase against phase and phase against ground before putting into operation.

Humid windings might cause creeping current, arcing and ruptures.

The insulation resistance of the stator winding must be at least 1,5 megohm on generators for 220 – 1000 V measured at a winding temperature of 20 °C.

In case of lower values the winding must be dried.

For insulation testing of the rotor it is necessary to separate the inverter from the rotor, as otherwise the test voltage causes damages to the inverter.

The insulation resistance of the rotor winding must reach the value of

$$\geq 4 [U_{\text{rotor}} (\text{kV}) + 1] \text{ megohm,}$$

measured at a winding temperature of 20 °C (68 °F).

(U_{rotor} = locked-rotor voltage – see data on the rating plate)

For determination of the insulation resistance the measuring voltage has to be 1000 V.

Possibly existing overvoltage suppressors which are connected to the generator can invalidate the insulation resistance. In case of doubt the overvoltage suppressors have to be disconnected.

4.3

Rotational direction



For the terminal identification of three-phase motors is applicable:

If the alphabetical sequence or natural sequence of the terminal identifications corresponds with the time sequence of the phases, the motor shall have a clockwise rotation. This rule applies to all motors, even if they are not suitable for clockwise rotation.

The rotor connection to KLM according to the above mentioned sequence will result in a clockwise rotation for short-circuited stator.

For anticlockwise rotation the direction of rotation can be changed by exchanging two phase conductors on the rotor terminals. (has to be agreed upon with the inverter manufacturer)

Installation and commissioning

4.4



Operation

- Coasting for a longer period is only admissible if the idle current is led through the inverter. (except for a normal period of 1–2 days for putting into operation)
- Without an “idle current leading”, there will be an increased wear of the brushes at a longer coasting period, since the oxide layer is removed. With the oxide layer already existing from operation a coasting for a definite period of some days normally is harmless.
- For lower power outputs, e.g. shortly before switching off/standstill, the rotor current must on the average not remain under 30% of the rated current for the rotor. Also in this case an idle current leading through the inverter has to be provided, if the above mentioned rotor current amount is not reached.

Rated current for the rotor – is rotor current indication (maximum value on the rating plate)
At standstill of the wind power plant the generator must not be subject to higher vibrations at standstill than 0,2 mm/s. In case of higher vibration values at standstill, standstill marks and damages in the antifriction bearings will occur.



Dielectric strength (rotor winding)

- du/dt is not allowed to exceed 1,5 kV/ μ s
 - also the voltage height (line-to-line voltage) may repetitively exceed 2,0 kV, but not 2,3 kV at a maximum.
- If necessary the above values have to be realized by installing filters into the inverters (inverter manufacturer)



Maximum speed

The maximum speed is determined in the data sheet or in the generator specification and is not allowed to be exceeded.

4.5

Check before commissioning



- Check whether the bearing lock has been removed!
See paragraph 3.2 “Bearing lock”!
- Check sliprings for perfect condition!
- Check whether brushes are lying on the sliprings!
- Observe data on the rating plate!
- Check whether voltage and frequency of the generator comply with the mains data!
- Check whether the rotational direction is correct!
- Check whether protective measures have been taken!
- Check whether the electrical connections are securely tightened and whether the monitoring devices are connected and adjusted acc. to the specifications!
- Check whether the earth brush is grounded!
- Check whether the alarm device for the available brush length is connected and adjusted!
- Check insulation resistance of the stator and rotor winding!
- Check coolant temperature!
- Check whether the air intake openings and cooling surfaces are clean!
- For water-cooled generators check whether the cooling water circuit is functioning!
- If a forced ventilation is available, check whether the forced ventilation is functioning and that the directional rotation is correct!

Maintenance

5 Maintenance

5.1 General

Due to very different operating conditions it is only possible to indicate general periods for a trouble-free operation.

Therefore the maintenance intervals have to be adapted to the actual circumstances (dirt accumulation, switching frequency, load, etc.).

Indications in the additional instructions must be observed as well.

In case of failures or exceptional conditions which represent an electrical or mechanical overloading of the machine (e.g. excessive load, short circuit, etc.) an appropriate inspection has to be made.

5.2 Bearings and greasing

The bearings are equipped with regreasing devices and automatic grease quantity control used to segregate the used grease. Regreasing of the bearings is done by means of a grease gun through the nipples provided on the end shields.

An overfilling of the bearing chambers is not possible since in case of an extended regreasing the used grease will be thrown off by a rotating disk in the outer grease chamber through an aperture in the end shield.



Regreasing during operation only!

Risk of accidents! Pay attention to rotating parts.

Regreasing intervals, grease quantity and grease quality are indicated on the instruction plates at the generator. Regreasing, however, is to be made at least twice a year.

Only use clean grease. Grease nipples have to be cleaned!

If the generator is equipped with **grease removal rams**, the used grease must be removed after regreasing by pulling the ram at the bearing several times to the stop, with the generator in operation.

If the generator is equipped with **grease collecting chambers**, these chambers are to be dismounted at generator standstill acc. to the intervals on the instruction plate and the used bearing grease is to be removed. If this is not done, the grease piles up and the bearings are overheated.



Extending the regreasing intervals endangers the bearing and might risk a deterioration of the sealing provided by the grease and thus the ingress of dust into the bearing.

If the generators have not been operated for a longer period we recommend even for new generators to regrease the bearings before putting into operation, especially if noises are heard due to congealing grease in the bearing. In the course of running-in increased bearing noises might occur for a short period.

Maintenance

The bearing noise is not critical as long as the operating temperature of the bearing is not yet reached and if the noise is caused by the dynamic viscosity of the bearing grease.

The temperature of the bearings is continuously to be checked. Up to a room temperature of 40 °C (104 °F) an excess temperature of 80 K is acceptable if the recommended grease quality is used.

We would like to point out that the grease quantity regulation can only work properly if the grease types specified by us are used. Decisive is the plate fixed on the generator.

Only use antifriction bearing grease as specified for regreasing on the lubrication plate.

Generators for special operating conditions are supplied with a separate greasing plate stating the grease quality to be used as well as the regreasing intervals.



Relubrication with grease of a different saponification basis. e.g. sodium saponified grease, might cause a deterioration and elimination of the grease effect and thus a total damage of the bearings.

5.3

Maintenance of sliprings and brushes



Generator has to be disconnected.

The slipring chamber is only to be opened when the generator is switched off or at standstill.

It must be guaranteed that the system is de-energized and protected against unintentional restarting.



After commissioning (approx. 8 h) the operational behaviour and the wear of the brushes has to be checked. Depending on the contact width of the brushes the sliprings should show a uniform colouring (oxide layer) and be worn uniformly.

Maintenance

Machines with wear indicator

For machines with wear indicator the visual inspection is not necessary. The brushes should be replaced immediately, however, at the latest after 170 operating hours when the first alarm was given. A period of 170 operating hours corresponds with the wearing allowance for a normal brush wear.

Machines without wear indicator

If no wear indicators (e.g. micro-contact switch) are used, suitable intervals to replace the brushes have to be determined by inspections on site.

The brushes have to be replaced before the available length of 16 mm (see Fig. 5) is reached.

For checking of the available length the brushes have to be pulled out of the brush holder.

At the latest the brush has to be replaced before the center of the mark (see Fig. 5) is reached.

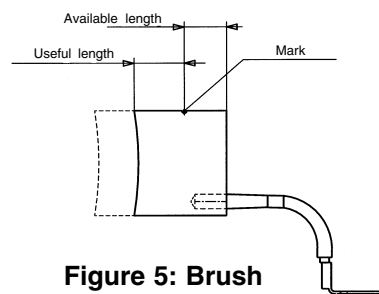

Figure 5: Brush

At every maintenance it has to be checked if the useful length is still sufficient until the next maintenance, so that the available length is not becoming too short.



Quality of the brushes is adapted to the application, only the specified original spare parts are allowed to be used. In case of using an unsuitable brush quality the warranty claim becomes invalid.

When mounting new brushes they must be carefully seated with the aid of abrasive cloth placed round the sliprings, until approx. 90 % of the contact face is lying on the slipring.



With premachined brushes attention must be paid that brushes of a suitable radius are used. A subsequent seating of the brushes is not required.

Burnt sliprings have to be replaced. It is not admissible to continue operation.

If the generator is provided with filters in the air guide of the slipring enclosure, this filter has to be cleaned at every replacement of the brushes.

Clogged or damaged filters have to be changed at every replacement of the brushes.

Maintenance

Cleaning of the slipring chamber:

Slipring design	Closed slipring enclosure IP 54/55 without filter	Closed slipring enclosure IP54/55 with filter	Open slipring enclosure IP 23
Cleaning interval	2000 h	4000 h	4000 h

At every cleaning interval the slipring questionnaire (see Appendix A) has to be completed and kept with the service life file of the wind power plant.

5.4 Maintenance instructions for cleaning of the slipring enclosure



Generator has to be disconnected.

The slipring chamber is only to be opened when the generator is switched off or at standstill.

It must be guaranteed that the system is de-energized and protected against unintentional restarting.

Do not use any tools causing damages to the slipring surface at improper use.

5.4.1 closed slipring enclosure

- 1) Tools, fixtures and spare parts for cleaning of the closed slipring enclosure
 - a) Ring spanner, open end- and socket spanners of different spanner openings
 - b) Torch lamp
 - c) Vacuum cleaner with flexible suction hose
 - d) Brushes (of different sizes)
 - e) Cleaning cloth
 - f) Dust mask
 - g) 2 pcs. of Spare filter mats (divided type, if filter available)
 - h) 2 pcs. of Inline-filters
 - i) Electric high-duty cleaner e.g. Rivolta S.L.X.-TOP
- 2) Unscrew cover on the servicing opening and put it aside, then remove coarse dust on brush holder and slipring with a big brush. Higher carbon dust accumulations have to be removed from the enclosure with the vacuum cleaner immediately.
- 3) Unscrew rear cover plate to the dust filter and put it aside, remove used filter mats.
- 4) Following the adhering brush dust around the micro-contact switches and the insulating rings (between the sliprings) as well as around the brush connecting wires has to be removed completely with a brush or a cleaning cloth and vacuumed.
If this is not observed there is the danger that leakage currents occur between micro-switch and brush holder or between the sliprings.
- 5) Then remove the residual brush dust on the slipring body as well as in the complete slipring enclosure – especially in the edges and gaps.
The brush dust accumulated on the bottom of the slipring enclosures can now be removed completely by means of a vacuum cleaner.

Maintenance

- 6) After dry cleaning the insulating surfaces and the sides of the slipring and the brush holder have to be wiped off with a cloth, which is moistened with an electric high-duty cleaner e.g. Rivolta S.L.X-TOP from the Bremer Leguil GmbH.

No fluid solvents (like e.g. cold cleaner) should be used for cleaning, as those will emulsify with the coal brush dust to a pasty mass which smears when it is wiped off.

- 7) Now the filter mats can be cleaned or replaced. Following to this, the filter opening has to be sealed with the cover plate.
- 8) When the existing Inline-filters were detached from the plastic tubes, these have to be replaced by new ones.
- 9) Upon termination of all other maintenance work the lateral maintenance cover has to be refastened correctly to the slipring enclosure with screws.

5.4.2 open slipring enclosure

- 1) Tools, fixtures and spare parts for cleaning of the slipring enclosure
 - a) Ring spanner, open end- and socket spanners WAF13
 - b) Torch lamp
 - c) Vacuum cleaner with flexible suction hose
 - d) Brushes (of different sizes)
 - e) Cleaning cloth
 - f) Electric high-duty cleaner e.g. Rivolta S.L.X-TOP
 - g) Dust mask
- 2) Unscrew cover on the servicing opening and put it aside, then remove coarse dust on brush holder and slipring with a big brush. Higher carbon dust accumulations have to be removed from the enclosure with the vacuum cleaner immediately.
- 3) Following the adhering brush dust around the micro-contact switches and the insulating rings (between the sliprings) as well as around the brush connecting wires has to be removed completely with a brush or a cleaning cloth and vacuumed.
If this is not observed there is the danger that leakage currents occur between micro-switch and brush holder or between the sliprings.
- 4) Then remove the residual brush dust on the slipring body as well as in the complete slipring enclosure – especially in the edges and gaps.
The brush dust accumulated on the bottom of the slipring enclosures can now be removed completely by means of a vacuum cleaner.
- 5) After dry cleaning the insulating surfaces and the sides of the slipring and the brush holder have to be wiped off with a cloth, which is moistened with an electric high-duty cleaner e.g. Rivolta S.L.X-TOP from the Bremer Leguil GmbH.

No fluid solvents (like e.g. cold cleaner) should be used for cleaning, as those will emulsify with the carbon brush dust to a pasty mass which smears when it is wiped off.

- 6) Now the filter mats can be cleaned or replaced. Following to this, the filter opening has to be sealed with the cover plate.

Maintenance



For all slipring enclosures the following has to be observed !

Special care as regards creep distances is required for the cleaning work on the following components:

- **Brush holder**
- **Micro-switches on the brush holders**
- **Brush holder stud**
- **Slipring (insulating surfaces of the sliprings)**
- **Leads on the sliprings**
- **Front-end of the slipring**

5.5

Terminal locations, terminals and ventilating passages

At every brush replacement or cleaning of the slipring chamber have to be checked:

- the cleanliness of terminal locations and terminals
- electrical connections with regard to tightness
- cleanliness of the air-flow channels
- tightening torques of the screws and nuts in the slipring chamber and on the terminal boxes



The intake openings and the cooling surfaces of surface-cooled (TEFC) motors must be protected against obstruction and contamination. Pay attention to the correct water pressure in the cooling system.

If required, the water chambers have to be rinsed and cleaned from deposits.

Never use sharp-edged tools for cleaning.

5.6

Displacing of the brush holders

Generator has to be disconnected.

The slipring chamber is only to be opened when the generator is switched off or at standstill.

It must be guaranteed that the system is de-energized and protected against unintentional restarting.



Pull out the brush from the brush holder.

Loosen fixing screws from the brush holder.

Displace the brush holder on the brush holder stud.

Fasten brush holder with screws at a radial distance of 2 mm between brush holder and slipring surface.

Pay attention that the brush holder is in the middle of the slipring contact face.

Put the brush into the brush holder and check the contact pressure.

Maintenance

5.7 Tightening torques for bolted joints of electrical connections

(e.g. rotor connection)

If no further data are given, the following tightening torques are applicable for the terminal studs and nuts.

Permissible continuous current intensity A	Studs ¹⁾		Hexagon nuts ^{1) 2)}	Washer for eye connection ^{1) 2)}	Tightening torques Nm
	Thread <i>d</i>	Material			
10	M 3,5	CuZn37F45	DIN 439 – AM 3,5 – Ms	DIN 125–3,7–Ms	0,8
16	M 4		DIN 439 – AM 4 – Ms	DIN 125–4,3–Ms	1,2
25	M 5		DIN 439 – AM 5 – Ms	DIN 125–5,3–Ms	2
63	M 6		DIN 439 – BM 6 – Ms	DIN 125–6,4–Ms	3
100	M 8		DIN 439 – BM 8 – Ms	DIN 125–8,4–Ms	6
160	M 10		DIN 934 – M10 – Ms	–	10
250	M12		DIN 934 – M 12 – Ms	–	15,5
315	M 16	CuZn37F38	DIN 934 – M 16 – Ms	–	30
400	M 20		DIN 934 – M 20 – Ms	–	52
200	M 10		DIN 934 – M 10 – Ms	–	10
315	M 12	E-Cu57F25 or E-Cu58F25	DIN 934 – M 12 – Ms	–	15,5
400	M 16		DIN 934 – M 16 – Ms	–	30
630	M 20		DIN 934 – M 20 – Ms	–	52
800	M 24 x 2		DIN 934 – M24x2 – Ms	–	80
1000	M 30 x 2		DIN 934 – M30x2 – Ms	–	150
1250	M33 x 2		DIN 934 – M33x2 – Ms	–	197
1600	M36 x 3		DIN 934 – M 36x3 – Ms	–	252

¹⁾ Admissible are also materials which are at least electrically and mechanically equivalent.

²⁾ Further nuts and washers, e.g. used for fixing, can be of steel. Heating by eddy currents must be considered.

Additional equipment

- 6 Additional equipment**
Only available on special order.
Additional equipment must be connected to the control system and cause an immediate switching-off when the admissible values are exceeded.
- 6.1 Temperature monitoring *)**
The temperature sensors for monitoring e.g. of the stator winding temperature, the bearings, the coolant must be connected to the additional terminals in the main terminal box or by one or several terminal boxes.

The temperature sensors have to be connected according to the relevant wiring diagram. For connection the specifications and instructions acc. to paragraph 4.2. "Connection" are applicable.
- 6.2 Space heater *)**
The space heater has to be connected to the terminals provided in the main terminal box or by an additional terminal box acc. to the relevant wiring diagram. For connection the specifications and instructions acc. to paragraph 4.2. "Connection" are applicable.
- 6.3 Incremental encoder *)**
For connection and operation the applicable wiring diagram and the operating instructions of the incremental encoder have to be observed.
- 6.4 Speed switch *)**
Speed switch (centrifugal switch) for safety monitoring of speed.
For operation the applicable wiring diagram and the operating instructions of the speed switch have to be observed.
- 6.5 Micro-switch for brush alarm device *)**
Micro-switch for wear monitoring of the brushes.
For connection and operation the instructions and the valid wiring diagram of the brush alarm device are applicable.

*) Only available on special order.

Spare parts

7 Spare parts

When ordering spare parts, please state:

Spare part designation

Motor type

Serial number

Example: End shield DE
AFWA-400LB-04A
8 386 388

Motor type and serial number are indicated on the rating plate.

FLENDER LOHER				Slipring questionnaire			
Generator data:							
Generator type:				last change of brushes at (h):			
Generator number:				electr. power (kWh):		Commissioning:	
Place of installation:				Operating hours:		last inspection:	
Sketch: Numbering of the brushes							
Brush length in mm (Numbering to sketch):				Alignment of the brushes on the sliprings:			
Material carbon brushes:				<input type="checkbox"/> center <input type="checkbox"/> left <input type="checkbox"/> right			
Material earth brushes:				Contamination of slipring mounting:			
	x	x		x		x	<input type="checkbox"/> severe <input type="checkbox"/> medium <input type="checkbox"/> weak
K1	L1	M1		E1			Remarks on the place of dust accumulation:
K2	L2	M2		E2			
K3	L3	M3					
K4	L4	M4					
Slipring condition:							
Slipring body			K	L	M		
Running-in of the slipring (mm)							
Contact face appearance (s. table)							
Assessment table for contact face appearance							
A normal looking contact face, with uniform colour light- to dark-brown B Contact face with severe score marks and traces C torn contact face with insignificant scoring D patchy contact face E random distribution of light dots at varying density on the contact face F severe burns with scaling surface G otherwise to be remarked:							
Remarks to contact surface and condition of the carbon:							
Please fill in completely for evaluation purposes!							
Inspection date:				Signature Responsible:			

FLENDER LOHER

LOHER AKTIENGESELLSCHAFT

P.O.Box 1164 · D-94095 Ruhstorf

Hans-Loher-Str 15 · D-94099 Ruhstorf

Phone ++49(85 31) 39-0 · Fax ++49(85 31) 3 93 08

<http://www.loher.de>

e-mail: info@loher.de