

Operating Instructions

N – R 443 en 09.03

Explosion-proof three-phase motors
with squirrel cage for low voltage,
with antifriction bearings,

Protection type “Increased Safety”
(to Directive 94/9/EC)

ENG.-071..-. to 355..-., EMG.-071..-. to 355..-..
ENH.-071..-. to 355..-., EMH.-071..-. to 355..-..
ENL.-100..-. to 355..-., EML.-100..-. to 355..-..
ENS.-090..-. to 560..-., EMS.-090..-. to 355..-..
EMU.-100..-. to 355..-., ENW.-132..-. to 560..-..
ENR.-630..-. to 800..-..
JNR.-355..-. to 800..-., JNW.-355..-. to 800..-..

Protection type “n”
(to Directive 94/9/EC)

ANGK/ANGL-071..-. to 355..-., AMGK/AMGL-71..-. to 355..-..
ANHK/ANHL-071..-. to 355..-., AMHK/AMHL-071..-. to 355..-..
ANLK/ANLL-100..-. to 355..-., AMLK/AMLL-100..-. to 355..-..
ANSK/ANSL-090..-. to 560..-., AMSK/AMSL-090..-. to 355..-..
AMUK/AMUL-100..-. to 355..-., ANWK/ANWL-132..-. to 560..-..
ANRK/ANRL-630..-. to 800..-..
JNRK/JNRL-355..-. to 800..-., JNWK/JNWL-355..-. to 800..-..

LOHER GmbH
P.O.Box 1164 • 94095 RUHSTORF
Hans-Loher-Str. 32 • 94099 RUHSTORF
GERMANY
Phone +49 8531 39-0 • Fax +49 8531 32895
E-mail: info@loher.de
<http://www.loher.de>

Table of contents

	Page
1	Safety and commissioning instructions 2
2	Instructions to protection type "Increased Safety" 5
3	Instructions to protection type "n" 9
4	Description 11
5	Transport 13
6	Installation and commissioning 14
7	Maintenance 21
8	Additional equipment 23
9	Spare parts and components 24
10	Storage instructions 26
11	Faults and remedies 30
12	EC Declaration of Conformity 31
	Appendix 1; Grease life and grease quantities 33
	Appendix 2; Alignment check 34

Subject to modifications
Loher GmbH 2003
All rights reserved

Safety and commissioning instructions



1 Safety and commissioning instructions

1.1 Warning symbols in these instructions

The symbols are used in these operating instructions to point out to particular dangers.



This symbol refers to a dangerous situation which can cause fatal or serious injuries or considerable damage to property.



This symbol refers to a possibly dangerous situation which can cause injuries and damage to property if it is not avoided.

1.2 General

Low voltage motors have dangerous, **live** and **rotating** parts, and probably hot surfaces. All work for transport, connection, commissioning and maintenance are to be made by **qualified, responsible** specialists (EN 50110-1/VDE 0105 Part 1, IEC 60364 must be observed). An inadequate behaviour can cause severe **damages to persons and property**.

1.3 Specified use

These low voltage motors are only meant for use in **industrial** plants. They are in accordance with the harmonized standards of the series **EN 60034 (VDE 0530)**. For a use in hazardous areas the additional instructions for the type of protection have to be observed (pages 5 to 10). Air-cooled types are suitable for ambient temperatures from **-20 °C (68 °F) to +40 °C (104 °F)** as well as altitudes \leq **1000 m** above sea level. It is **imperative** to observe differing data on the rating plate. The conditions at the site of application must comply with **all** indicated data on the rating plate.

Low voltage motors are **components** to be installed into machines in accordance with Directive 89/392/EEC.

Commissioning is not allowed as long as the conformity of the end product with this directive is not established (also observe EN 60204-1).

1.4 Transport, storage

The carrier is **immediately** to be informed on **damages** found upon delivery; **commissioning** must **not be admitted**, if required. Screwed-in lifting eyes are to be tightened. They are only suitable for the weight of the low voltage motor, **no** additional loads are allowed to be attached. If required, sufficiently dimensioned means of transport (e.g. rope guides) are to be used. Prior to commissioning the **transport locking devices** are to be removed. Reuse for further transports. For storage of low voltage motors, take care of a **dry, dustfree and low-vibration** ($v_{\text{eff}} \leq 0.2$ mm/s) ambience (bearing damages with motor at standstill). Before commissioning the insulation resistance is to be measured. In case of values $\leq 1\text{k}\Omega$ per Volt of rated voltage the winding must be dried. Observe "Storage instructions".

Safety and commissioning instructions



1.5

Installation

Take care of an even ground, suitable fastening of feet or flange and an exact alignment for direct coupling. Avoid that structure-dependent natural frequencies occur within the rotary frequency and the double mains frequency. Turn rotor **by hand**, listen to abnormal frictioning noises. **Check direction of rotation** before coupling (see section "Electrical Connection").

Pulleys and couplings are **only** allowed to be installed or removed with suitable devices (Heating!) and to be covered **with protection against accidental contact**. Avoid inadmissible belt tensions (Technical List). The **balance** of the low voltage motor is indicated on the shaft end face or on the rating plate (H = half key, F = full key). In case of a half key (H), the coupling must also be balanced with a half key. In case of any protruding and visible part of the key take care of the mass balancing.

If required, make the necessary pipe connections. Mounting types with the shaft end facing upwards are to be provided with a cover by **the customer**, avoiding that foreign bodies fall into the fan.

The ventilation must **not be hindered** and the outgoing air – also from adjacent units – must not be directly sucked in again.

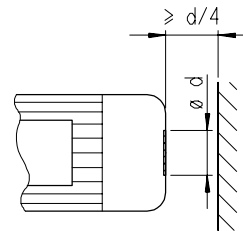

1.6

Electrical connection

All work is only allowed to be done by **qualified** personnel with the low voltage motor at **standstill, electrically dead** and **locked against restart**.

This is also applicable to auxiliary circuits (e.g. space heater).

Check de-energizing!

A non-observance of the tolerances indicated in EN 60034-1/VDE 0530, part 1 – voltage $\pm 5\%$, frequency $\pm 2\%$, curvature, symmetry – will result in an excessive heating and is influencing the electromagnetic compatibility. Observe data on the rating plate as well as wiring diagram in the terminal box.

Observe connection and differing data on the rating plate as well as the wiring data in the terminal box.

Connection is to be made in such a way that a **durably safe**, electrical connection is maintained (no uncovered wire ends); especially provided cable end equipment is to be used. A safe **earthing** is to be made.

The minimum air gaps between uninsulated and live parts themselves and to earth must not be lower than the following values: 8 mm at $U_N \leq 550$ V, 10 mm at $U_N \leq 750$ V, 14 mm at $U_N \leq 1100$ V.

The terminal box must **be free** of foreign bodies, dirt as well as humidity. Unused cable entries and the box itself are to be sealed against **dust** and **water**. For trial operation without driving elements the **key** is to be **secured**. For low voltage motors with brake it is to be **checked** before putting into operation, if the **brake** is perfectly functioning.

Safety and commissioning instructions



1.7

Operation

Vibration severities $v_{\text{eff}} \leq 3.5$ mm/s ($P_N \leq 15$ kW) or 4.5 mm/s ($P_N > 15$ kW) are not critical at coupled operation. In case of changes compared with normal operation – e.g. **higher temperatures, noises, vibrations** – the cause is to be found, if required, contact the manufacturer. Even for trial operation the safety devices are not allowed to be put out of function. In **case of doubt** switch off the low voltage motor.

In case of heavy dirt accumulation, the air ducts must be cleaned at regular intervals.

Bearings with regreasing devices are to be regreased with low voltage motor **running**. Observe saponification class! Danger of accident! Pay attention to rotating parts. If grease drainholes are sealed with a plug, **remove these plugs** before putting into operation. Boreholes have to be sealed with grease. Replacement of bearings in case of permanent lubrication see Appendix 1 or motor documentation.

1.8

Warranty

The **warranty requires** that these instructions for safety and putting into operation as well as the following sections of these operating instructions and the information on possible additional units are strictly observed.

Instructions to electrical machines in protection type “Increased Safety”

2 Protection type “Increased Safety”

Marking of the motors with EC–type–examination certificate to Directive 94/9/EC:

CE 0102  II 2 G EEx e II T.

For explosion-proof motors in protection type “Increased Safety” acc. to EN 50014 and EN 50019 the following items have to be observed:

2.1 General

Increased risk in hazardous areas requires a strict observance of the safety and commissioning instructions.

2.2 Specified use

Explosion-proof electrical machines are in accordance with the standards of the series EN 60034 as well as EN 50014 – 50020. In hazardous areas they are only allowed to be used in accordance with the specifications of the competent supervising authority, which decides on the explosion hazard and zone classification.

Type of protection, temperature class as well as special conditions are indicated on the rating plate and in the EC–type–examination certificate.

– Device group II (hazardous areas by gas), Category 2 (= Zone 1)

If the certificate number is supplemented by an X, the special conditions to be complied with in the EC–type–examination certificate have to be observed.

This category includes electrical machines, e.g. also in protection type “Increased Safety”, to be used in areas hazarded by an explosive atmosphere.

Inverter operation has to be certified. It is imperative to observe the separate manufacturer specifications. For protection type “e” it is required to identify the motor, inverter and safety device as belonging together and the admissible operating data have to be determined in a common EC–type–examination certificate.

It is possible that the size of the voltage peaks produced by the inverter are adversely affected by the connection cable installed between inverter and electrical machine. In the system inverter-cable-electrical machine the maximum value of the voltage peaks on the terminals of the machine is not allowed to exceed the value mentioned in the separate manufacturer specifications.

2.3 Installation and electrical connection

The installation and operation of electrical equipment in hazardous areas requires the observance of the applicable national and international rules, e.g. regulation for operational safety (Betriebssicherheitsverordnung (BetrSichV)):

“Decree for safety and health protection regarding the provision of work equipment and its use at work, safety during operation of installations requiring supervision and the organization of industrial safety”.

For belt drives only those belts may be used which are allowed for hazardous areas.

The general safety and commissioning instructions are applicable for the electrical connection. Cable entries and plugs (for openings which are not used) must be tested for hazardous areas and approved by an EC–type–examination certificate acc. to Directive 94/9/EC.

Instructions to electrical machines in protection type “Increased Safety”



For delivery the special threads will be sealed with non-certified plugs (transport protection only). These plugs must in accordance with the corresponding protection type of the terminal box be replaced by certified cable entries with EC-type-examination certificate according to Directive 94/9/EC.

When connecting the motors, the connections inside the terminal box are to be given special care and attention. Furthermore a safe earthing connection has to be made (also see Paragraph 6.1 and 6.2).

When the leads are inserted into the terminal box, care must be taken that the leads are strain-relieved.

The inside of the terminal boxes must always be kept clean. The seals must be intact and fit correctly.

In operation the terminal box must always be tightly closed.



Cable-, lead entries and connecting cables must be suitable for ambient temperatures occurring.

For motors with cable entry (no terminal box at the motor) the cable (connecting lead) is to be connected in a housing, which meets the requirements of an approved type of protection according to EN 50014, if the motor is to be connected in an hazardous area.

2.4

Protective measures against overheating

If no other data are indicated in the test certificate or on the rating plate as to duty type and tolerances, the EEx e II machines are designed for continuous duty and normal, not frequently repeated starts, during which no essential temperature rise occurs at starting. The motors are only allowed to be used for the duty type stated on the rating plate.

Zone A in EN 60034-1 (VDE 0530, Part 1) – voltage $\pm 5\%$, frequency $\pm 2\%$, curvature, mains symmetry – has to be observed, in order to keep the temperature rise within the admissible limits. Higher deviations from the rated values can cause an inadmissible heating of the electrical machine and have to be stated on the rating plate.

In particular, each motor must be protected against overheating due to overload. The following notes must be observed:

According to EN 60079-14 all machines must be protected against overheating by a current-dependent delayed circuit breaker (with EC-type-examination certificate acc. to Directive 94/9/EC) with phase-failure protection in accordance with EN 60947 or by an equivalent equipment in all phases. The protective device must be adjusted to the rated current (Value must be indicated on the rating plate).

For explosion-proof electrical machines in protection type “Increased Safety” starting (starting time control with EC-type-examination certificate acc. to Directive 94/9/EC) is also monitored. If the rotor is blocked the circuit breaker must disconnect within the time t_E indicated for the respective temperature class. The requirement is met if the tripping time – indicated in the tripping characteristic curve (initial temperature $20\text{ °C} = 68\text{ °F}$) for the ratio I_A/I_N – does not exceed the indicated heating-up time t_E .

Electrical machines for heavy starting (acceleration time $> 1.7 \times$ time t_E) must be protected by a starting time control in conformity with the data of the EC-type-examination certificate.

Instructions to electrical machines in protection type “Increased Safety”

Windings with delta-connection must be protected in such a way that the circuit breakers are connected in series with the winding phases. For the selection and the adjustment of the circuit breakers, the rated value of the phase current, i.e. 0.58 times the rated current of the motor must be taken as basis. If such a connection is not possible, additional protective measures, e.g. thermal motor protection, are required.

Thermal motor protection by means of a direct temperature monitoring of the winding is admissible, when this is indicated on the rating plate. It consists of temperature sensors according to DIN 44081/44082. The PTC thermistors as sole protection ensure the explosion protection together with functionally tested tripping devices provided with the marking for protection type

 II (2) G.



If a continuity test of the temperature sensors should be required, it is not allowed to apply a voltage exceeding 2.5 V!

For pole-changing motors, independent and interlocking protective devices are required for each speed step. Recommended are devices which are tested and certified by a registered testing authority.

2.5

Maintenance and repair

For maintenance, repair and modifications on explosion-proof machines the relevant national rules the regulation for operational safety (Betriebssicherheitsverordnung), the safety instructions and descriptions of the general maintenance instructions have to be observed.

Any work directly influencing the explosion protection, like for instance

- repair work on stator or rotor winding and on the terminals
- repair work on the ventilation system,

has to be made at the manufacturer or by an approved workshop for electrical machines. This work has to be identified by an additional repair plate showing the following data:

- date
- company performing the work,
- kind of repair work
- identification symbol of the expert.

If the work is not done by the manufacturer, an approval by a licensed expert is required.

He must issue a written confirmation and the machine must be provided with his approval symbol respectively.

2.6

Spare parts

With the exception of standard, commercial and equivalent parts (e.g. screws) only original spare parts are allowed to be used (see spare parts list); in particular this also applies to gaskets. Components like e.g. terminals, cable- and lead entries are only allowed to be replaced by components with an EC-type-examination certificate.

Measures to maintain the explosion protection during operation

2.7



Mechanical explosion protection

All machines being marked to Directive 94/9/EC have to be checked at regular intervals for mechanical damages which could be an ignition risk.

Special attention must be paid that the intervals for bearing replacement and regreasing intervals or grease change intervals as well as oil change intervals to be specified by the operating company are observed.

When the rated service life is reached the bearings should either be replaced or proven by an inspection that there are no mechanical damages.

– For bearings which cannot be regreased it is ensured that the rated service life will only be reached clearly after reaching of the grease service life.

– The calculated rated service life of the bearings can be seen in the data sheet of the machine, if it was specified particularly or for structural reasons specified for an individual case.

– For machines which are exposed to forces applied externally (e.g. belt force or axial load from the driven machine) the bearing service life is a minimum of 20.000 hours for the full load indicated in the technical list.

– All of the other machines have a rated bearing service life of at least 40.000 hours.

– For bearings with separate oil supply the operating company is to watch suitably that the lubrication is maintained.



The motors are suitable for **ambient temperatures from -20°C (-4°F) up to $+40^{\circ}\text{C}$ (104°F)** resp. for the temperature range indicated on the rating plate.

In special design with installed heating or heating via the winding the motor is allowed to be operated up to the minus temperature indicated on the rating plate.

In this case it must be observed that the heating is switched on at least 6 hours before commissioning of the motor or motor starting.

Only when the housing temperature of -20°C (-4°F) is reached, the motor is allowed to be put into operation. Prior to switch on the motor, the heating is to be switched off.

During motor operation the heating must not be switched on.

The heating data for voltage and current are indicated on the additional plate being attached to the motor.

Motors in the mechanical special design "for low temperature" can be put into operation up to the minus temperature indicated on the rating plate.

Instructions to electrical machines in protection type “n” EEx nA II

3 Protection type “n” EEx nA II

Marking of the motors with EC–type–examination certificate acc. to Directive 94/9/EC:

CE  II 3 G EEx nA II T.

For explosion-proof motors in protection type “n” acc. to EN 50014 and EN 50021 the following items have to be observed:

3.1 General

The increased risk in hazardous areas requires a strict observance of the safety and commissioning instructions.

3.2 Specified use

Explosion-proof electrical machines are in accordance with the standards of the series EN 60034 as well as EN 50014 – 50021. In hazardous areas they are only allowed to be used in accordance with the specifications of the competent supervising authority, which decides on the explosion hazard and zone classification.

Type of protection and temperature class are indicated on the rating plate.

– Device group II (hazardous areas by gas), Category 3 (= Zone 2)

This category includes electrical machines, e.g. also in protection type “n”, to be used in areas hazarded by an explosive atmosphere.

Inverter operation has to be certified. It is imperative to observe the separate manufacturer specifications. For protection type “n” it is required to identify the motor and inverter as belonging together and the admissible operating data have to be determined in the common test certificate – data information and certified by the EC Declaration of Conformity respectively.

It is possible that the size of the voltage peaks produced by the inverter are adversely affected by the connection cable installed between inverter and electrical machine. In the system inverter-cable-electrical machine the maximum value of the voltage peaks on the terminals of the machine is not allowed to exceed the value mentioned in the separate manufacturer specifications.

3.3 Installation and electrical connection

The installation and operation of electrical equipment in hazardous areas requires the observance of the applicable national and international rules, e.g. regulation for operational safety (Betriebssicherheitsverordnung (BetrSichV)):

“Decree for safety and health protection regarding the provision of work equipment and its use at work, safety during operation of installations requiring supervision and the organization of industrial safety”.

For belt drives only those belts may be used which are allowed for hazardous areas.

The general safety and commissioning instructions are applicable for the electrical connection. Cable entries and plugs (for openings which are not used) must be tested for hazardous areas and approved by an EC–type–examination certificate acc. to Directive 94/9/EC.

When connecting the motors, the connections inside the terminal box are to be given special care and attention. Furthermore a safe earthing connection has to be made (also see Paragraph 1.6 and 6.2).

Observe the air and creepage distances to EN 50014/50019.

Instructions to electrical machines in protection type “n” EEx nA II



When the leads are inserted into the terminal box, care must be taken that the leads are strain-relieved.

The inside of the terminal boxes must always be kept clean. The seals must be intact and fit correctly.

In operation the terminal box must always be tightly closed.

Cable-, lead entries and connecting cables must be suitable for ambient temperatures occurring.

For motors with cable entry (no terminal box at the motor) the cable (connecting lead) is to be connected in a housing, which meets the requirements of an approved type of protection according to EN 50014, if the motor is to be connected in an hazardous area.

3.4

Protective measures against overheating

If no other data are indicated in the test certificate or on the rating plate as to duty type and tolerances, the EEx nA II machines are designed for continuous duty and normal, not frequently repeated starts, during which no essential temperature rise occurs at starting. The motors are only allowed to be used for the duty type stated on the rating plate.

Zone A in EN 60034-1 (VDE 0530, Part 1) – voltage $\pm 5\%$, frequency $\pm 2\%$, curvature, mains symmetry – has to be observed, in order to keep the temperature rise within the admissible limits. Higher deviations from the rated values can cause an inadmissible heating of the electrical machine and have to be stated on the rating plate.

In particular, each motor must be protected against overheating due to overload. The following notes must be observed:

According to EN 60079-14 all machines must be protected against overheating by a current-dependent delayed circuit breaker with phase-failure protection in accordance with EN 60947 or by an equivalent equipment in all phases.

The protective device must be adjusted to the rated current (Value must be indicated on the rating plate).

Windings with delta-connection must be protected in such a way that the circuit breakers are connected in series with the winding phases. For the selection and the adjustment of the circuit breakers, the rated value of the phase current, i.e. 0.58 times the rated current of the motor must be taken as basis. If such a connection is not possible, suitable circuit breakers, e.g. with phase failure monitoring have to be used.

Thermal motor protection by direct temperature control of the winding is admissible when the motor is designed and tested for this purpose.



If a continuity test of the temperature sensors should be required, it is not allowed to apply a voltage exceeding 2.5 V!

For pole-changing motors, independent and interlocking protective devices are required for each speed step.

3.5

Maintenance and repair see Paragraph 2.5

3.6

Spare parts see Paragraph 2.6

3.7

Mechanical explosion protection see Paragraph 2.7

Description

4 Description

4.1 Overall construction and design

Mounting arrangement acc. to EN 60 034-7: see dimension drawing or rating plate

Mounting dimensions for surface cooling up to frame size 315 M acc. to

DIN 42 673 (foot mounted)

DIN 42 677 (flange mounted)

from frame size 315 L, see dimension drawing

all frame sizes acc. to IEC 60072-1 or IEC 60072-2: see dimension drawing

Connection designations acc. to

DIN VDE 0530 part 8

IEC 60 034-8: see wiring diagram

Enclosure acc. to

EN 60 034-5: see rating plate

Cooling acc. to EN 60034-6:

IC 411 Surface cooling (TEFC) or hollow fin cooling or

IC 511 Tube cooling or

IC 611 Internal cooling with mounted-on air-to-air heat exchanger or

IC 81 W Internal cooling with air-water heat exchanger

IC 71 W Water jacket cooling

Details of the motor design are indicated in the valid technical catalogues.

4.2 Bearings

The motors are equipped with grease-lubricated antifriction bearings. The standard version of the bearings in motors up to frame size 280 is permanently lubricated.

The bearings of the surface-cooled motors from frame size 315 are equipped with regreasing devices and automatic grease quantity control.

4.3 Cooling

4.3.1 Surface cooling (TEFC) for the Type E...-... and A..K-... / A..L-...

Design for fin and hollow fin or tube cooling, where an external fan takes in the cooling air through the openings in the fan cover and presses the air over the surface or through the cooling tubes of the stator frame. For hollow fin or tube cooling the heat dissipation is supported by a closed cooling air circuit inside the motor.

4.3.2 Internal cooling with mounted-on air-water heat exchanger for the Type JNW.-...

The motors are equipped with air-water circuit coolers. The cooling air led through the heat exchanger and motor is recooled in the heat exchanger and the heat loss is dissipated through the cooling water. The heat exchangers are provided with special ribbed tubes.

4.3.3 Internal cooling with mounted-on air-to-air heat exchanger for the Type JNR.-...

The motors are equipped with air-to-air heat exchanger. The cooling air led through the heat exchanger and motor is recooled in the heat exchanger and the heat loss is dissipated through the cooling medium air.

4.3.4 Water jacket colling for the Type ENW.-... and ANW.-...

The stator housing has a double casing. For water channelling it is sub-divided by spirals where the cooling water passes through. This results in good heat dissipation. Additionally, this reduces the danger that suspended matters carried along in the water can deposit.

Description

4.4 Motor frame

4.4.1 Construction for surface cooling (TEFC) Type E...-... and A..K-... / A..L-...

Depending on the frame size, the stator frame and end shields are made of grey cast iron or steel. The fan cover is made of sheet steel. The stator frame surface is provided with cooling fins, hollow fins or tubes and mounted-on terminal box.

4.4.2 Construction for internal cooling with air-water heat exchanger Type JNW.-...

The stator frame and end shields are of steel. The stator frame surface is plain with mounted-on terminal box. Between the stator jacket and the stator core there are spacing ribs making possible the internal cooling. An air-water circuit cooler is mounted onto the ventilation openings.

4.4.3 Construction for internal cooling with air-to-air heat exchanger Type JNR.-...

Like for the internal cooling with air-water heat exchanger, however, an air-to-air heat exchanger is mounted onto the ventilation openings.

4.4.4 Construction for water jacket cooling Type ENW.-... and ANW.-...

Stator frame and end shields are made of grey cast iron or steel. The stator housing is designed as double casing, through which the cooling water is led. The housing is provided with inlet and outlet for the cooling water.

4.5 Stator winding

The stator winding is executed in insulation class (see rating plate) acc. to EN 60034-1. High-quality enamelled wires, suitable surface insulating materials and the type of insulation provide a high level of mechanical and electrical stability with a high utilization factor and a long service life.

4.6 Rotor

The rotor in motors of small frame sizes is equipped with a squirrel cage made of aluminium die cast, in case of larger frame sizes with a cage in brazed version. The rotor is dynamically balanced. The balance is indicated on the shaft end face or the rating plate, see Paragraph 6.1 "Installation". The motors in standard design meet the requirements of vibration level N acc. to EN 60034-14/DIN VDE 0530-14/IEC 60034-14, in special cases level R (reduced) or S (special).

4.7 Terminal boxes

If required, additional terminals for the monitoring devices are available inside the terminal box. On special order an additional terminal box will be installed for larger motors (see dimension drawing).

The number of available terminals is indicated in the wiring diagrams.

4.8 Monitoring devices

Monitoring devices are only available on special request.

See wiring diagram!

Transport

5

Transport



Danger!

For handling during transport the stator construction of the motor is equipped with lifting eyes, where the lifting hooks can be fixed.

Check whether screwed lifting eyes are securely tightened.

Lift motors only by using these lifting eyes. Several lifting eyes must always be used together.



Danger!

Lifting of the motors on other parts (e.g. shaft ends, cooler) is not permitted, since this might result in considerable damages.

The lifting eyes are only suitable for the motor weight. Additional loads attached to the motor must never be lifted using these eyes.

5.1

Check before installation

Check whether the motor has been damaged during transport. If the packing is damaged to such an extent that a motor damage is to be assumed, the packing should be removed in the presence of a representative agent of the carrier.

5.2

Bearing lock

(for motors with cylindrical roller bearings only.)



The rotor of the motor is locked in order to avoid damages to bearings caused by vibrations at standstill:

- by red marked locking screws in the bearing cap
- or by a transport locking mechanism fixed to the shaft end.

Before the motor is mounted, the locking screws must be loosened by 10 mm and the transport locking device must be removed (see instruction plate on the motor).

After this, it must be possible to turn the shaft by hand.

We recommend loosening of the bearing lock only after the drive element has been fitted.

The transport locking mechanism **has to be** reused for further transports.

Prevent failures and thus avoid damages to persons and property.



The person responsible for the installation has to make sure, that

- safety- and operating instructions are available and observed
- operating conditions and technical data acc. to the order are observed
- protective equipment is used
- specified maintenance work is carried out.

Installation and commissioning

6 Installation and commissioning

A most careful mounting and alignment of the motors on an absolutely even surface is imperative to avoid distortions when the screws are being tightened. For machines to be coupled attention must be paid to a careful alignment. See Appendix 2 for alignment check. As elastic as possible couplings should be used.

In case of using e.g. pulleys, gears etc. care must be taken that the permissible radial and axial shaft loads are not exceeded.

Motors with surface cooling (TEFC), hollow fin cooling, tube cooling or internal cooling with air-to-air heat exchanger

(for all indicated types except Type JNW.–..., ENW. –... and ANW. –...)



Maximum permissible coolant temperature (room temperature on site) acc. to EN 60034–1/IEC 60034–1 is max. 40 °C (104 °F) max. and a permissible altitude up to 1000 m above mean sea level (other values see rating plate).

Care must be taken that the cooling air can flow without hindrance into the air inlet openings and freely pass through the air outlet openings and cannot be directly sucked in again. Suction and outlet openings must be protected from obstructions and coarse dust.

Motors with water jacket cooling (Type ENW. –... and ANW. –...)



Before commissioning of water-cooled motors, the troublefree function of the cooling-water circuit must be guaranteed. It must be ensured that the motor will only be switched on when the cooling-water circuit is in operation. It must be kept functioning until the motor comes to standstill after switching-off. Inlet and outlet openings are found on the motor housing.

The cooling water circuit is to be monitored. Normally, the motor is equipped with PTC thermistor sensors, which switch off the motor if the cooling-water circuit fails. If the housing is provided with vent plugs for the water chamber, venting is to be made for the first filling and thereafter at regular intervals.

Only clean, non-aggressive cooling water is to be used. Admissible content of suspended solids is max. 10mg/l.

A most careful mounting and alignment of the motors on an absolutely even surface is imperative to avoid distortions when the screws are being tightened. For machines which are to be coupled it must be paid attention to a careful alignment. See Appendix 2 for alignment check. As elastic as possible couplings should be used.



The inlet temperature of the cooling water should be at least 20 °C (68 °F).

Temperatures below 20 °C (68 °F) result in higher formation of condensation water and motor failure.

Admissible inlet and outlet temperature, maximum pressure and the required amount of cooling water are indicated on the motor plates.

The motors are only allowed to be operated at a coolant temperature over 0 °C (32 °F). For lower temperatures it is required to add an antifreeze due to reduced cooling effect. Consultation with the motor manufacturer is required.

Installation and commissioning



Motors with mounted-on air-water heat exchanger for the Type JNW.-...

Before commissioning of the motors, the troublefree function of the cooling-water circuit must be guaranteed. It must be ensured that the motor will only be switched on when the cooling-water circuit is in operation. It must be kept functioning until the motor comes to standstill after switching-off.

Admissible inlet and outlet temperature, maximum pressure and the required amount of cooling water are indicated on the motor plates.

6.1

Mounting

Fitting of pulleys or couplings.

First the shaft end should be cleaned (not with emery cloth) and then greased. Pulley or coupling should be fitted only with the aid of a fitting device. For this purpose the threaded centering hole in the shaft end can be used. Insert the threaded bolt into the thread. Then place the steel washer, the diameter of which is large enough to cover the hub borehole of the pulley or coupling. The pulley and coupling is to be pulled up onto the shaft end by means of a nut or a suitable hydraulic device.



The fitting of the drive elements by means of hammer blows is not permitted because of the risk of bearing damages.

When replacing the bearings those must only be removed and reinstalled by means of suitable devices using the shaft centering. Only original spare parts must be used.

The rotor of the motor is dynamically balanced. **Balance** is indicated on the shaft end face or the rating plate. (**H** = half key, **F** = full key). Take care of the balance for installation of the driving element!

The balancing of the transmission elements to be fitted must be adapted to the rotor balancing. In case of half key balancing any **protruding and visible** part of the key has to be removed or a mass balancing is to be made.

The motor must only be mounted and operated according to the specified mounting arrangement (see rating plate).

In case of using e.g. pulleys, gears etc. care must be taken that the permissible radial and axial shaft loads are not exceeded.

For explosion-proof motors only belts which are permissible for hazardous areas are allowed to be used.

Installation and commissioning

6.2 Connection, insulation resistance

Connection must only be made by an expert and in accordance with the valid safety regulations. The relevant installation- and operating instructions as well as national and international rules have to be observed.

Observe data on the rating plate!

Compare type of current, mains voltage and frequency (see Paragraph 6.3.1)!

Observe connection!

Observe rated current for setting of the protective switch!

Connect motor in accordance with the wiring diagram provided in the terminal box!

The motor must be protected against excessive heating.

See Paragraph 2.4.

For earthing the motor is provided with an earthing terminal, which depending on the mounting arrangement is either located on the frame resp. on the flange end shield. In addition all motors have a protective conductor terminal inside the terminal box.

As protection against dust and humidity unused cable entries in the terminal box must have a torsionproof seal. All terminal screws and nuts have to be securely tightened to avoid excessive transition resistances (see Paragraph 6.6).

Protective measures are to be taken.



In case of terminal boards with U-shaped terminal washers the conductors to be connected have to be bent in U-shape and placed underneath the terminal washers. See sketch!

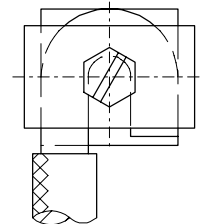

In case of motors with terminal boxes which have ground surfaces between cover and base, a thin grease film is to be applied for sealing and against corrosion.

After longer storage periods or standstill (also see Paragraph 10.1.2) the insulation resistance of the winding must be measured phase against phase and phase against ground before putting into operation.

Humid windings might cause creeping currents, arcing and ruptures. In case of values $\leq 1 \text{ k}\Omega$ per Volt of rated voltage measured at a winding temperature of $20 \text{ }^\circ\text{C}$ ($68 \text{ }^\circ\text{F}$) the winding must be dried.

6.3 Rotational direction and designation of the terminals acc. to DIN VDE 0530-8/IEC 60334-8

6.3.1 In standard design surface cooled (TEFC) motors up to frame size 315 are suitable for both directions of rotation.

Motors suitable for one rotational direction only are identified by an arrow on the motor for the correct direction. Terminals U1, V1, W1 connected to phase L1, L2, L3 (in alphabetical sequence or natural sequence) always result in clockwise rotation. This rule applies to all motors, even if they are not suitable for clockwise direction.

Installation and commissioning

- 6.3.2 Change of rotational direction:
For DOL (direct on-line) starting and in pole-changing motors with separate windings the direction of rotation can be reversed by exchanging two mains conductors on the terminal board of the motor.
For motors with star/delta starting and pole-changing motors with Dahlander winding, 2 (two) mains conductors at the input to the motor switch have to be exchanged.
For a machine with one shaft end only or with two shaft ends of different diameters, that rotational direction of the rotor is considered as the direction of rotation, being noticed by anybody when looking at the front end or thicker shaft end.
- 6.3.3 With forced ventilation the direction of rotation is separately marked by an arrow on the forced ventilation itself.

6.4 Air-water heat exchanger

(for the Type JNW.–...)

For connection and commissioning the instructions for air-water heat exchangers must be considered. Admissible inlet- and outlet temperature, max. pressure and the required cooling water volume are indicated on the motor plates.

6.5 Check before commissioning



- Observe data on the rating plate!
- Check whether voltage and frequency of the motor comply with the mains data!
- Check whether the bearing lock has been removed!
See Paragraph 5.2 “Bearing lock”!
- Check whether the rotational direction is correct and for inverter operation, that the limit speed is not exceeded!
- Check whether the motor is protected as specified in the regulations!
- Check and make sure that in case of star/delta-starting, because of the risk of inadmissible operational loads, the switching from star to delta can only be executed after fading of starting current of the star step!
- Check whether the electrical connections are securely tightened and whether the monitoring devices are correctly connected and adjusted!
- Check whether protective measures have been taken: earthing!
- Check coolant temperature!
- Check whether additional equipment – if existing – is functionable.
- Check whether the cooling air inlet openings and cooling surfaces are clean!
- If a condensation water drain hole exists, open the hole for a short time, that the accumulated condensation water can be drained off!
- Check whether the motor is securely fixed!
- In case of a belt drive, check the belt tension!
- Check whether the cover of the terminal box is closed and whether the cable entries are properly sealed.
- Check whether the cable glands and the plugs (for unused entry threads) are approved by an EC–type–examination certificate according to Directive 94/9/EC.
- For water-cooled motors it is to be checked whether the cooling water circuit is functioning.
- For forced-ventilated motors it is to be checked, whether the forced ventilation is functionable and in operation when the main motor is in operation.

Installation and commissioning

6.6 Tightening torques for screwed joints

6.6.1 General

If no other data are indicated the following torque limits (screw and nut) are applicable.

Note: Screws which become unusable have to be replaced by new ones of the same strength class and type.

6.6.2 Screwed joints for electrical connections

Thread	Tightening torque [Nm]	Thread	Tightening torque [Nm]
M 4	1.2	M 12	15.5
M 5	2	M 16	30
M 6	3	M 20	52
M 8	6	M 24	80
M10	10	M 30	150

6.6.3 Screwed joints strength class 8.8 and A4-70

Tightening torques for screws of the strength class 8.8 and A4-70 (A4-80) only in components with higher strength (e.g. grey cast iron, steel).

Thread	Tightening torque [Nm]	Thread	Tightening torque [Nm]
M 4	2.3	M 14	105
M 5	4.6	M 16	160
M 6	7.9	M 20	330
M 8	19	M 24	560
M10	38	M 30	1100
M 12	66	M 36	1900

6.6.4 Screwed joints strength class 5.6

Tightening torques for screws of the strength class 5.6, 4.6, A2 or for screws in components with lower strength (e.g. aluminium).

Thread	Tightening torque [Nm]	Thread	Tightening torque [Nm]
M 4	1.1	M 14	49
M 5	2.1	M 16	75
M 6	3.7	M 20	150
M 8	8.9	M 24	260
M10	18	M 30	520
M 12	30	M 36	920

Installation and commissioning

6.6.5

After entry of the cable into the terminal box the glands and the parts used for the strain relief are to be tightened with the corresponding torque in accordance with the data of the cable gland manufacturer.

The assembly torque limits depend on the used cable gland as well as the cable or supply line and must therefore be determined by the user.

The Loher standard glands supplied with the motor have at least to be tightened according to the table.

Table: Assembly torque limits for Loher standard cable glands [Nm]

Cable gland for EEx e II Type HSK-M		
Nominal size	Union nut	Threaded connection
M12x1.5	5	7
M16x1.5	5	7
M20x1.5	5	7
M25x1.5	7	10
M32x1.5	7	10
M40x1.5	7	10
M50x1.5	7	10
M63x1.5	7	10
M75x1.5	–	–

Cable gland for EEx e II Type ADE 1F, ADE 4F			
Nominal size	Gasket No.	Union nut	Threaded connection
M40x1.5	9	35	47
M40x1.5	10	52	70
M50x1.5	10	52	70
M50x1.5	11	55	74
M63x1.5	12	65	87
M63x1.5	13	75	100
M75x1.5	13	75	100
M75x1.5	14	104	139

Installation and commissioning

6.7 Inverter operation

For inverter operation the insulation of the motor winding is subject to a higher load than for mains operation.

Voltage peaks (especially for PWM inverters with long motor cable)

- The design of the terminal box concerning the air and creepage distances allows the inverter operation with voltage peaks (\hat{U}_{LL} = Maximum value of the conductor-to-conductor voltage and \hat{U}_{LE} = Maximum value of the line-to-earth voltage) up to $\hat{U} = 1866$ V.
- To avoid the formation of partial discharges, the voltage at the motor terminals must be limited, depending on the rise time t_A , to values which are below the characteristic curve of the chart "Dielectric strength curve" (see diagram below)

Dielectric strength curve

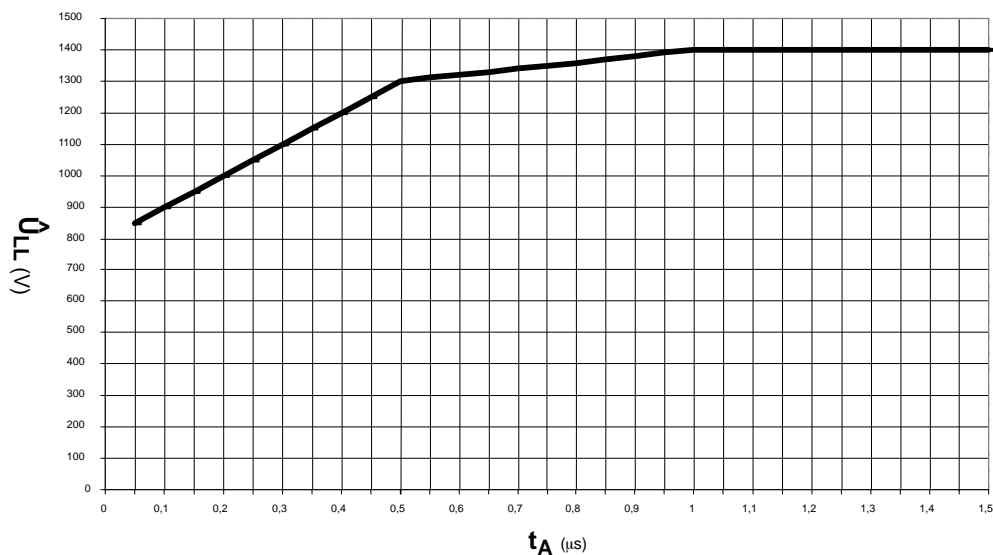

In order to ensure the explosion protection it is required that the EEx e motors and EEx nA II motors are tested and certified together with the respective inverter.

The inverter parameters (e.g. voltage-frequency characteristic) adjusted at the test are not allowed to be changed any more.

A thermal motor protection as sole protection or in connection with the inverter must be available.

The built-in temperature sensors (PTC thermistors) which must be suitable for sole protection are to be connected to a tripping device provided with the EC-type-examination certificate according to Directive 94/9/EC.

Maintenance

7 Maintenance

The responsible for the facility must ensure that the specified maintenance work is made adequately.

7.1 Bearings and greasing

7.1.1 The bearings in totally enclosed fan-cooled (TEFC) motors up to frame size 280 are permanently lubricated. In case of deviations this is marked by indication plates on the motor. For normal coolant temperatures (see EN 60034-1 or page 2 of these instructions) the motors are greased in our plant, which under normal operating conditions must only be replaced after several years (see Appendix 1).

7.1.2 Bearings of totally enclosed fan-cooled (TEFC) motors from frame size 315 (upon customer request also for the range from frame size 160 to 280) are equipped with regreasing devices and automatic grease quantity control. The regreasing of the bearings is done by means of a grease gun through the nipples provided on the end shields. Overfilling of the bearing chambers is not possible since in case of an extended regreasing the used grease will be thrown off by a rotating disk in the outer grease chamber through an aperture in the end shield.



Regreasing during operation only!

Danger of accident! Pay attention to rotating parts.

Regreasing intervals, grease quantity and grease quality are indicated on the instruction plates at the motor. Regreasing, however, is to be made at least once a year.

If the motor is equipped with **grease removal rams**, the used grease must be removed after regreasing by pulling the ram at the bearing several times to the stop, with the motor in operation.

If the motor is equipped with **grease collecting chambers**, these chambers are to be dismantled at motor standstill acc. to the intervals on the instruction plate and the used bearing grease is to be removed. If this is not done, the grease piles up and the bearings are overheated.



Extending the regreasing intervals endangers the bearing and might risk a deterioration of the sealing provided by the grease and thus the ingress of dust into the bearing. If the motors have not been operated for a longer period we recommend even for new motors to regrease the bearings before putting into operation, especially if due to congealing grease in the bearing there are noises which are caused by vibrations of the bearing cage. In the course of running-in increased bearing noises might occur for a short period. The bearing noise is not critical as long as the operating temperature of the bearing is not yet reached and if the noise is caused by the dynamic viscosity of the bearing grease.

The temperature of the bearings is continuously to be checked. Up to a room temperature of 40 °C/104 °F a heating-up of 80 K is acceptable if the recommended grease quality is used.

Maintenance

We would like to point out that the grease quantity regulation can only work properly if the grease types specified by us are used. Decisive is the plate fixed on the motor!

Only use antifriction bearing grease as specified for regreasing on the motor plate, i.e. for the ambient temperature range from -25 °C (-31 °F) to $+70\text{ °C}$ ($+158\text{ °F}$) lithium based grease (e.g. Shell Alvania R3), for the ambient temperature range from -60 °C (-76 °F) to $+80\text{ °C}$ ($+176\text{ °F}$) special grease (e.g. Klüber Isoflex Alltime SL2). Admissible ambient temperature for motors: see paragraph 1.3.

Motors for special operating conditions are supplied with a separate greasing plate stating the grease quality to be used as well as the regreasing intervals.



Relubrication with grease of a different saponification basis. e.g. sodium saponified grease, might cause a deterioration and elimination of the grease effect and thus a total damage of the bearings.

In case of 2 and 4 pole motors it might happen that by the use of unsuitable greases the grease quantity regulation fails and when pressing new grease into the bearings they get abnormally hot due to overfilling. In such cases the bearings have to be cleaned thoroughly by using cold-degreasing agent, and be refilled with suitable grease.

7.2



Terminal locations, terminals, ventilating and water passages

Depending on the operating conditions, the following should be done in certain intervals

- cleaning of terminal locations and terminals
- checking of the electrical connections with regard to tightness (see Paragraph 6.6 for tightening torques)
- cleaning of the air-flow channels.

Both the cooling air inlets and the cooling surfaces must be protected against obstruction and contamination.

- If required, the water chambers are to be flushed and cleaned from deposits.

Never use sharp-edged tools for cleaning.

7.3

Air-water heat exchanger

(motors with air–water heat exchanger Type JNW.–...)

For maintenance please consider the instructions for the air-water heat exchanger.

7.4

Condensation water drain hole

If the motor has a condensation water drain hole, it has to be opened at regular intervals to have the accumulated condensation water drained off.



Attention must be paid to seal the condensation water drain hole by a screw with lock washer to ensure the protection type.

Additional equipment

8 Additional equipment

On special order only.

8.1 Temperature monitoring*

The temperature sensors for monitoring e.g. of the stator winding temperature, the bearings, the coolant must be connected to the additional terminals in the main terminal box or by one or several additional terminal boxes.

The temperature sensors have to be connected according to the relevant connection diagram. For connection the specifications and instructions acc. to Paragraph 6.2 "Connection" are applicable.

8.2 Space heater*

Heating capacity and connection voltage: See special plate on the motor. The space heater has to be connected by an additional terminal box acc. to the relevant connection diagram.

For connection the specifications and instructions acc. to Paragraph 6.2 "Connection" are applicable. An operation of the space heater is only allowed when the motor is switched off. The space heater must never be switched on during motor operation.

8.3 Forced ventilation*

Observe direction of rotation! (see arrow for directional rotation.)

Forced ventilation is to be connected acc. to the wiring diagram inside the terminal box.

During operation of the main motor the forced ventilation must be switched on!

The forced ventilation is dissipating the heat loss during operation of the main motor. When switching off the main motor a temperature-dependant follow-up run of the forced ventilation is required.

8.3.1 To be checked when commissioning the main motor:

Check whether the forced ventilation is functioning and in operation when the main motor is switched on!

* On special order only.

Spare parts and components

9 Spare parts and components

When ordering spare parts or components please state the type and serial number of the motor.
Both data can be taken from the rating plate.

Standard version:

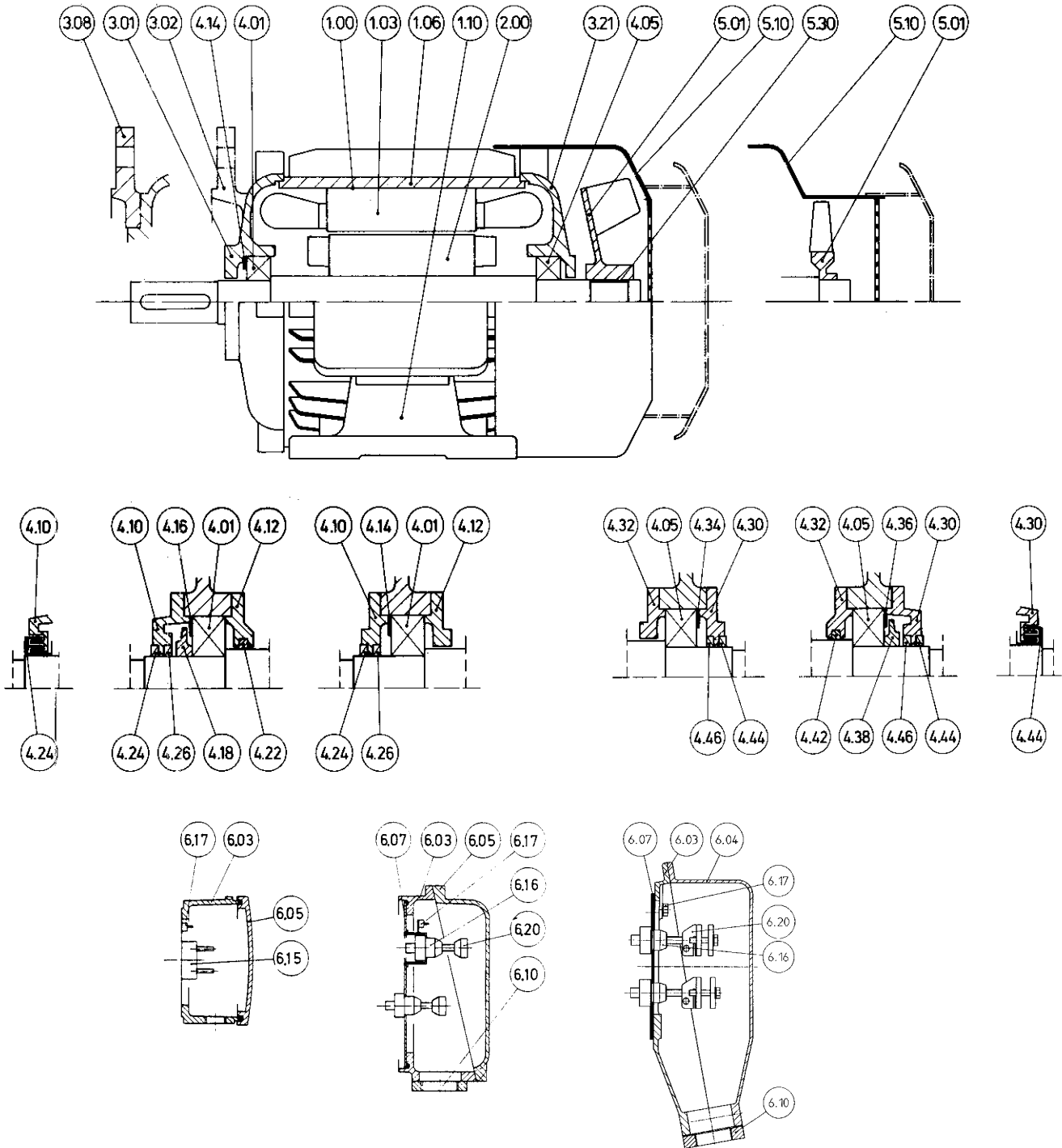

Spare parts and components

1.00	Stator, complete	4.34	Resilient preloading ring, NDE
1.03	Stator core with winding	4.36	Grease guide disk, NDE
1.06	Stator housing	4.38	Centrifugal disk, NDE
1.10	Mounting feet, unmachined (1 pair)	4.42	Felt packing ring, NDE
2.00	Rotor, complete (balanced)	4.44	Outside gasket, NDE
		4.46	Inner gasket, NDE
3.01	End shield, DE	5.01	External fan, complete
3.02	Flange shield, DE	5.10	Fan cover, complete
3.08	Flange disk, DE	5.14	Protective grid, complete
3.21	End shield, NDE	5.30	Spring fastener
4.01	Bearing, DE		
4.05	Bearing, NDE		
4.10	Outside bearing cap, DE	6.03	Base of terminal box
4.12	Inner bearing cap, DE	6.04	Upper part of terminal box
4.14	Resilient preloading ring, DE	6.05	Terminal box cover
4.16	Grease guide disk, DE	6.07	Bushing plate
4.18	Centrifugal disk, DE	6.10	Cable entry
4.22	Felt packing ring, DE	6.15	Terminal board, complete
4.24	Outside gasket, DE	6.16	Bushing terminal
4.26	Inner gasket, DE	6.17	Accessory terminal
4.30	Outside bearing cap, NDE	6.20	Clamping
4.32	Inner bearing cap, NDE		

The parts shown are available in different sets depending on type, size, mounting and enclosure. They are available from our works.

When ordering spare parts, please state:

Spare part designation

Motor type

Serial number

Storage instructions

10 Storage specifications

10.1 For motors which have to be stored for a period of up to 2 years, the following is to be observed:

10.1.1 **Storage**

10.1.1.1 The motors are to be stored dry, dustfree and at room temperature. In this case no special packing is required. Otherwise the motors must be packed into plastic foil with humidity-absorbing substances (e.g. Branogel) or into an air-sealed foil. Protective cover against sun and rain is to be provided.

10.1.1.2 In order to avoid secondary failures at the bearings caused by vibrations at standstill, for example by adjacent running machines, the motors are only allowed to be stored in vibrationless rooms.



10.1.1.3 For transport the motors with roller bearings have to be equipped with a bearing lock at the driving end. It is to remain locked until commissioning resp. to be re-installed after an inspection or a trial operation. A locking device is not necessary and not available, if the bearing is axially preloaded.



10.1.1.4 On motors with sealed condensation water drain holes it might be necessary to have the condensation water drained off. Afterwards the boreholes are to be sealed again.



10.1.2 **Commissioning**

10.1.2.1 Before commissioning the insulation resistance of the winding must be measured by qualified personnel phase against phase and phase against mass. Damp windings may cause leakage currents, arcing and ruptures. In case of values $\leq 1\text{k}\Omega$ per Volt of the rated voltage measured at a winding temperature of 20 °C (68 °F) the winding must be dried. Drying is possible by feeding of the winding with single phase a.c. current. The voltage has to be adjusted in a way that the recommended values of the heating current in accordance with Illustrations a) and b) are not exceeded.

The temperature should reach 80 °C (176 °F) and being active for several hours. Drying is also possible in a drying kiln.

Storage instructions

Recommended heating circuits and maximum heating currents

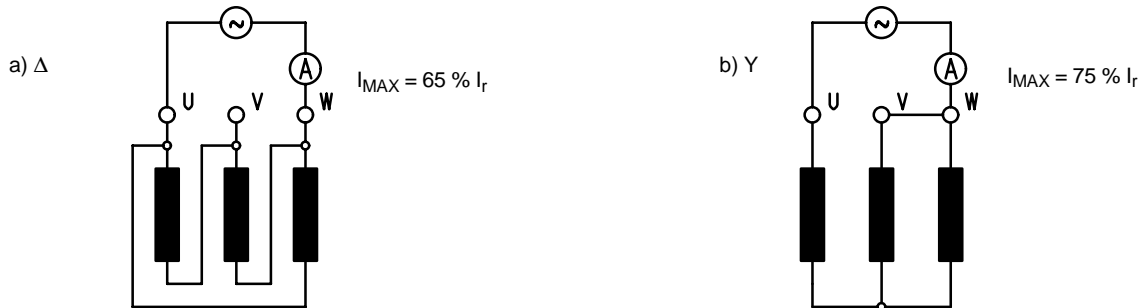

10.1.2.2 On motors with bearing lock this one has to be removed before commissioning.

10.1.2.3 Antifriction bearings, lubrication



If adequately stored for a longer time it can be assumed that within 2 years the lubricating grease in the bearings is not affected. Motors with permanent lubrication can be put into operation after having checked the insulation resistance of the winding and a short trial run.

For motors with insulation class F a lithium-saponified antifriction bearing grease with a dripping point of at least 180 °C (356 °F) is used for normal ambient temperatures.

For the motors with insulation class H and certain special motors, the used special lubricating grease is indicated on an instruction plate attached to the motor.

10.1.2.4 For motors with a regreasing device it is advisable to regrease both bearings shortly after commissioning at running motor.

Grease type, grease quantity and regreasing intervals are marked on an additional plate attached to the motor.

The data for grease service life with regreasing intervals can surely be expected for motors in enclosure IP 55. The bearing is protected against the ingress of fine dust and of water in all directions, e.g. for outdoor installation without additional protection.

For motors with enclosure IP 44 and IP 54 these data apply with the restriction that the environmental load by dust and water is not exceeding the limits of EN 60034-5 with tests according to EN 60034-5.

10.1.3 **For motors which are transported and stored in assembled condition with the machine to be driven the following must be observed:**

10.1.3.1 Storage



a) The free shaft ends must be greased before installation of the motors as well as all of the other blank metal parts, e.g. foot- and flange surfaces or supporting faces of terminal boxes and covers. As protection against dust and humidity grease seals with antifriction bearing grease are to be installed at the shaft opening.

b) A humidity-absorbing substance (e.g. Branogel) is to be filled into the terminal boxes of the motors.

c) The machines are to be stored dry, dustfree and at room temperature.

d) For further measures the specifications according to the Paragraphs 10.1.1.2 – 10.1.1.4 are applicable.

A bearing lock is not necessary, if the bearings are preloaded by means of belt drive (10.1.1.3).

Storage instructions

10.1.3.2 **Commissioning**
Before commissioning the humidity-absorbing substance (e.g. Branogel) is to be removed from the terminal boxes and the measures according to 10.1.2 are to be performed.

10.1.3.3 For outdoor storage it is additionally to be observed:
Protective cover against the influence of sun and rain is to be provided, exchange of air must be possible to avoid condensation water.



After 2 months it must always be checked if the protective measures acc. to 10.1.3.1a are still given and functionable.

10.2 **For motors which are stored for more than 2 up to 4 years before commissioning additionally applies:**

10.2.1 **Storage**

10.2.1.1 The manufacturer must be informed on the storage time in the purchase order.

10.2.1.2 Shaft opening and terminal box cover are to be provided with grease seals of antifriction bearing grease. The motor shafts are not allowed to be rotated, as otherwise the protective grease coating is destroyed. If a movement of rotating parts is unavoidable, the protective grease coating has to be renewed.

10.2.1.3 A humidity-absorbing substance (e.g. Branogel) must be in the terminal boxes.

10.2.1.4 In case of permanent lubrication the antifriction bearings must due to the long standstill be greased with the special grease, e.g. "Klüber Staburags NBU 8 EP".

10.2.2 **Commissioning**

10.2.2.1 Before commissioning the humidity-absorbing substance (e.g. Branogel) is to be removed from the terminal boxes and the measures according to 10.1.2 are to be performed.

10.2.2.2 Antifriction bearings, lubrication

Motors with regreasing device must be relubricated immediately after commissioning with about the double grease quantity, until the used grease has been thrown out. Further greasing can then be made with the bearing grease indicated on the lubrication plate. During the running-in period increased bearing noises may occur, which are not dangerous, when the operating temperature of the bearing has not been reached and the noise is caused due to the dynamic viscosity of the bearing grease.

10.3 **If motors are stored at temperatures to –50 °C (–58 °F) the following must be observed in addition to the instructions according to Paragraph 10.1. and 10.2:**

10.3.1 The standard antifriction bearing grease for the motors as per catalogue is suitable for operating temperatures between –30 °C (–22 °F) and +130 °C (+266 °F). Temperatures to –50 °C (–58 °F) are harmless for the antifriction bearing grease, when the motors are at standstill or stored. (For an operation at –50 °C (–58 °F) a special grease, e.g. Klüber Isoflex Alltime SL2, is available for the bearings).



10.3.2 Motors with regreasing device are to be relubricated when put into operation. Compared to the indication on the lubrication plate the grease quantity has to be doubled.

Storage instructions

10.4 If motors with water jacket cooling or with air-water cooler are stored at temperatures up to -20 °C (-4 °F) the following must be observed in addition to the instructions of Paragraph 10.1 and 10.2:

The water has to be removed completely from the water coolers.

In any case the coolers have to be dried completely with hot air of max. 60 °C (140 °F) and then to be sealed.

Motors with coolers have to be stored in a dry and dustfree room.

Motors with regreasing device are to be relubricated when put into operation. Compared to the indication on the lubrication plate the grease quantity has to be doubled.

10.5 Further to these storage instructions all data of these operating instructions are to be considered. The manufacturer's warranty is only applicable if all of the above mentioned items are strictly observed.

Faults and remedies

11 Faults and remedies

Fault			Possible causes	Remedy
Bearing is too hot	Bearing noise*	Motor runs unevenly		
			Too much grease in bearing	Remove excess grease
			Bearing dirty	Replace bearing
			Belt tension too high	Reduce belt tension
			Coupling forces are pulling or pushing	Realign motor, correct coupling
			Coolant temperature above 40 °C (104 °F)	Adjust temperature of cooling air
			Not enough grease in the bearing	Grease according to specifications
			Motor incorrectly mounted	Check mounting type of motor
			Bearing grease dark coloured	Check bearing currents
			Scoring at bearing inner race, e.g. caused by motor start with locked bearing	Replace bearing, avoid vibrations at standstill
			Unbalance caused by pulley or coupling	Exact balancing
			Motor fastening instable	Check fastening

* If remedies described are insufficient, we recommend to replace the bearings.

Fault				Possible causes	Remedy
Motor does not start	Motor is too hot	High decrease in speed	Protective device triggers		
				Countertorque too high	Check motor- and load torque
				Mains voltage too low	Check mains conditions
				Phase interruption	Check mains supply
				Wrong winding connection	Observe wiring diagram and rating plate
				Overload	Compare data on rating plate
				Too many starts per hour	Observe rated duty type
				Insufficient ventilation	Check ventilation passages, check direction of rotation
				Insufficient cooling	Cooling water – Check inlet and outlet temperature
				Ventilation passages dirty or cooling water circuit obstructed	Clean
				Short-circuit of winding or terminal board	Measure insulation resistance
				Starting time exceeded	Check starting conditions

EC Declaration of conformity

12

EC Declaration of conformity

LOHER GMBH

**FLENDER
LOHER**

EC Declaration of Conformity

Manufacturer: Loher GmbH

Address: Hans-Loher-Straße 32
D-94099 Ruhstorf/Rott

Product description: Asynchronous three-phase motors with the protection types

Increased security "e" to
E...-063 ... to E...-800

Flameproof enclosure "d" to
D...-063 ... to D...-800

Pressurising "p"
A..P-355 ... to A..P-800
I..P-355 ... to I..P-800

The product described meets the requirements of the following European guidelines:

94/9/EC European parliament and council guideline on the adaptation of legal provisions within the member states for devices and protective systems for their correct use in explosion-endangered areas.

Accordance with the rules in these guidelines is proved by complete adherence to the following standards:

EN 50014	EN 50016	EN 60034
	EN 50018	EN 60204-1
	EN 50019	
	EN 50020	

Attachment of the CE label for the first time: 2000

The product described is determined for installation in a different machine.
Commissioning is not permitted until the conformity of the end product with guideline 89/392/EEC has been established.

First published: 10.00
Ruhstorf/Rott 21st January 2002



Hofbauer
Quality Assurance Manager



Dr. Neupert
Technical Manager

This declaration shall not be understood as a guarantee of features in the sense of product liability.
Please pay attention to the safety instructions in the product documentation.

C:\Home\SUSI\Zertifikate\EG-Konformitätserklärung-e,d,p-Rev.A.doc

Rev. A / 21st January 2002

Appendix 1

Grease life and grease quantities

for antifriction bearings of explosion-proof three-phase motors in protection type "Increased Safety" or "n", with squirrel cage for low voltage, with **permanent lubrication**.

Frame size	Grease life for permanent lubrication in ¹ operation hours at rated speed 1/min:						Grease quantities in g per bearing for permanent lubrication
	horizontal mounting (IM B)						
	3600	3000	1800	1500	1200	≤ 1000	
63	33000	33000	33000	33000	33000	33000	4
71							5
80							9
90							11
100	24000	33000	33000	33000	33000	33000	15
112							25
132							50
160	17000	24000	24000	24000	24000	24000	70
180							80
200		60					
225		70					
250	17000	17000	24000	24000	24000	24000	90
280							12000
	vertical mounting (IM V)						
	3600	3000	1800	1500	1200	≤ 1000	
63	24000	33000	33000	33000	33000	33000	4
71		5					
80		9					
90		11					
100	17000	24000	24000	24000	24000	24000	15
112							25
132							50
160	12000	17000	24000	24000	24000	24000	70
180							80
200		60					
225		70					
250	9000	12000	17000	17000	24000	24000	90
280							9000

The indicated grease life is applicable for an ambient temperature of max. 40 °C (104 °F).

For a temperature rise of 10 °C (50 °F) each the grease life is to be reduced by factor 0.7 of the chart value (max. 20 °C/68 °F = factor 0.5).

At an ambient temperature of 25 °C (77 °F) the double grease life can be expected, however, 33000 operating hours at a maximum.

1 Independently of the operation hours the antifriction bearing grease resp. the bearing (2Z bearings) have to be replaced after 3–4 years at the latest.

Appendix 2

FLENDER LOHER	Service report Alignment check	Page
--------------------------	------------------------------------------	------

Service No.:	Order No.:
Type:	Serial No.:

Coupling type:	Diameter:
----------------	-----------

Recommended accuracy for alignment*		
Speed (rpm)	Parallel offset (1/100 mm)	Angular offset (1/100 mm each)
750	9	9
1500	6	5
3000	3	2.5

Measured values at the coupling				
Measurement	Parallel offset		Angular offset	

Comments:

* If no values were specified by the coupling manufacturer

FLENDER

LOHER

LOHER GmbH
P.O.Box 1164 • 94095 RUHSTORF
Hans-Loher-Str. 32 • 94099 RUHSTORF
GERMANY
Phone +49 8531 39-0 • Fax +49 8531 32895
E-mail: info@loher.de
<http://www.loher.de>